

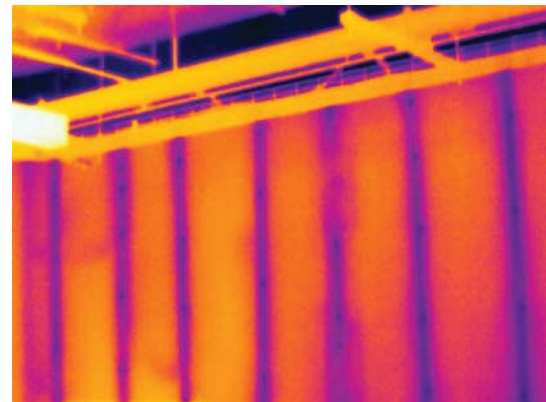

THERMAL PERFORMANCE OF FAÇADES

2012 AIA UPJOHN GRANT
RESEARCH INITIATIVE

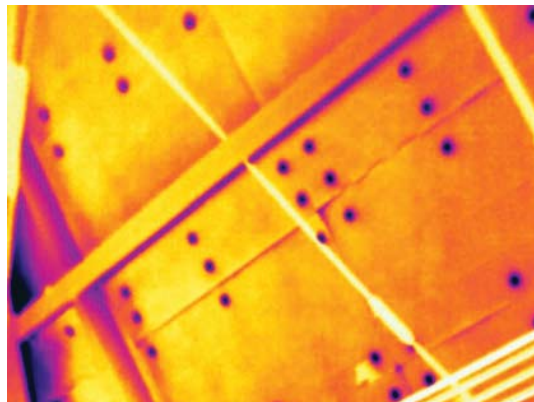
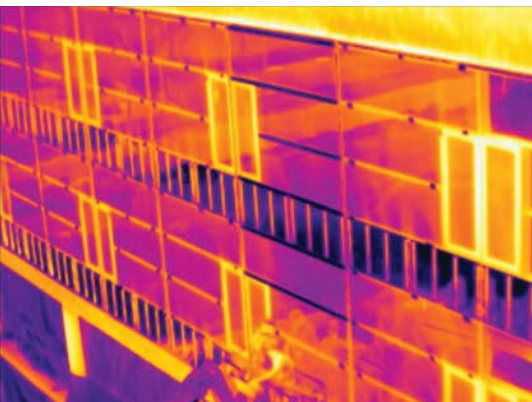

Final Report | November 2014

THERMAL PERFORMANCE OF FAÇADES

2012 AIA UPJOHN GRANT RESEARCH INITIATIVE

PAYETTE

290 Congress St., Fifth Floor
Boston, MA 02210-1005
617-895-1000
payette.com

Primary Investigators:

Charles Klee, AIA, LEED AP
Andrea Love, AIA, LEED AP BD+C

Researchers:

Miep Keller, AIA, LEED AP
Jeff Abramson, AIA, LEED AP
Marceli Botticelli, LEED AP
Matthew Fickett, AIA, LEED AP
Wesley Schwartz, AIA
Daniel Gonzales Brenes, AIA, LEED AP BD+C
Robert Carroll, AIA, LEED AP BD+C
Edin Kostovic
Nick Lavita, Assoc. AIA, LEED GA
Mollica Manandhar, AIA, LEED AP

THERMAL PERFORMANCE OF FAÇADES

Executive Summary

This investigation seeks to quantify the effects of thermal bridging in commercial facades and then propose alternative solutions to improve performance. Utilizing infrared images taken from targeted assemblies at 15 recently completed buildings; we have determined the actual performance and R-values of a range of façade types and conditions. We have compared these figures with the theoretical R-values calculated using materials specifications to quantify the discrepancy between theoretical design and actual performance. Although several insulation assemblies performed well without thermal bridging losses, complete assemblies were typically in the order of 50% less effective than the theoretical model. In certain complex assemblies, the research identified facades with as much as a 70% reduction in effective R-value.

Having understood the magnitude of the problem that is faced by typical construction detailing, the purpose of this investigation is to study methods for improving typical details to bring the theoretical and actual performance into closer alignment. Based on thousands of images collected, we identified 16 areas of thermal bridging that might commonly occur in commercial structures using industry standard details. Broken into two broad categories of façade systems and transitions/penetrations, they address systems such as curtain wall supports, rain screens, existing wall renovations and transitions such as parapets and foundation wall systems.

In order to test the benefits of proposed improvements, we developed 2-D heat transfer simulations of the observed conditions and calibrated these models to the data measured in the field. The thermal modeling provided insight into the most influential paths of heat transfer which helped to direct the efforts of pursuing detailing improvements.

Not surprisingly, assemblies with external insulation or uninterrupted insulation performed quite well. Systems with complex façade anchoring structures as are often used for brick veneer or rain screens, on the other hand fared more poorly. The research suggests that continuous penetrations such as traditional shelf angles and z-girts have a significant effect on thermal performance. The impacts of the assemblies can be substantially mitigated through discontinuous support that spans through the insulation. Improvements can be further reinforced by specifying low-conductivity materials avoiding aluminum and carbon steel.

Looking beyond the most typical façade details, the study also explores improvements to interfaces such as around windows and at roof and floor transitions. These assemblies tend to see comparatively high levels of thermal bridging and while they may not drive building heating and cooling loads, they can lead to performance concerns. In particular, the localized increased heat transfer associated with anomalous penetrations can lead to thermal comfort or condensation issues.

The study concludes that with relatively modest changes, typical façade detailing can be significantly improved to ensure that the structures we build perform as anticipated. Awareness of thermal bridging has been elevated over the past few years and this has led to the development of new materials and products marketed to address the problems. Our research suggests however, that there are no easy solutions and careful detailing must be coupled with the selection of non-conductive materials that penetrate through insulation barriers intermittently.



Introduction

Over the past twenty years, we have seen renewed interest in reducing the energy demand of buildings. At the building code level, groups such as ASHRAE have been steadily raising the bar on performance criteria for building envelopes and systems. Initiatives such as the AIA 2030 Commitment and the Department of Energy Building Technologies Program's energy saving goals go further to push the industry towards Net-Zero solutions within the next 15 to 20 years. The challenge faced by designers is to find and implement the technologies and solutions that can practically and economically affect the energy demands of our buildings. While the past ten years has seen a sharp increase in the attention paid to solar gain and protecting windows from the sun, far less progress has been made into managing conductive losses through improved building insulation performance. Increasing the thickness of insulation materials will only go so far if we fail to consider how discontinuities such as thermal bridging affect the overall performance of the system.

Thermal bridging in building construction occurs when thermally conductive materials penetrate through the insulation creating areas of significantly reduced resistance to heat transfer. These thermal bridges are most often caused by structural elements that are used to transfer loads from the building envelope back to the building superstructure. Though design professionals generally understand that thermal bridging is a concern, few can quantify the extent of its impact on building performance. With only a vague sense that this is a problem, it is unclear how aggressively we

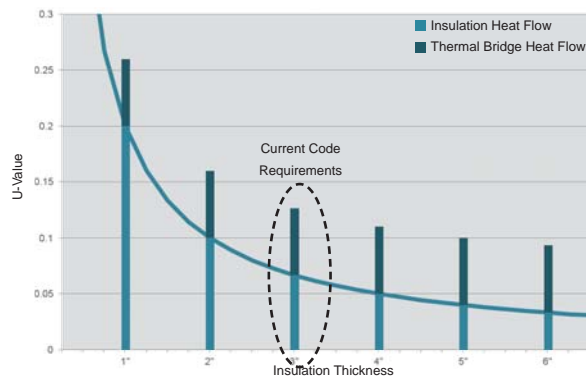

Chart of heat flow through wall assembly and thermal bridge



should work to minimize and mitigate the inevitable presence of thermal bridges. General research that has been published suggests that thermal bridges in conventional construction may reduce insulation effectiveness by as much as 40% (Morrison Hershfield 2011).

Considering this, we can see that the energy impact associated with thermal bridges will quickly become the dominant source of conductive losses as we increase insulation thickness in our pursuit of higher R values. This fails to acknowledge, however, that in many climate zones, energy code and standards already mandate "continuous insulation" values which are intended to take thermal bridges into effect. It is defined as follows:

Continuous Insulation: *Insulation that is continuous across all structural members without thermal bridges other than fasteners and service openings. It is installed on the interior or exterior or is integral to any opaque surface of the building envelope. (ASHRAE 2010)*

Accepting that this is an issue, the challenge becomes trying to evaluate how our facades perform and what can be done to improve them. Up until fairly recently, building construction was relatively simple and envelopes were essentially monolithic or limited to one or two layers of dissimilar materials. Because of this, the performance of traditional masonry and residential wood frame construction are better understood. Modern commercial and more progressive residential construction, however, involves layered construction including rain screens, air barriers, vapor

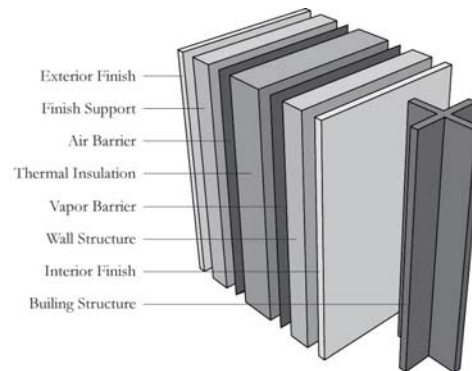

Diagram of current layered facade construction



retarders, and a multitude of insulation technologies. The variables and interactions of these systems are complex and no longer suited to the simple arithmetic analysis that formed the basis of heat loss calculations 30 years ago.

The intent of this research is to bring rigor to the investigation of thermal bridges in commercial construction, both by quantifying and understanding how built façades are actually performing, and also to investigate proposed improvements to common problem details. By using thermal imaging equipment to quantify actual performance of built installations, we are able to calibrate theoretical models and suggest quantified performance improvements. Coupled with computer models of the assemblies in these images, we have investigated the impact of the thermal bridges and proposed improvements. Preliminary results suggest that it is possible to affect 50% or greater reductions in the impact of common thermal bridges by using careful detailing and products that are readily available on the market.

Process Overview

The research project comprised of a multistep approach, starting with field observations of existing assemblies, followed by computer simulations of existing details and proposed thermal improvements.

Determining Design Intent R-values

Hand calculations of R-values based on the resistance of each layer of the envelope were based on shop drawings, construction documents, and/or Specification information, as appropriate. The surface resistance for air films, thermal resistances of plane air spaces, and material conductance when not known from manufacturer or project information, were taken from Chapter 26 of the 2009 ASHRAE Handbook Fundamentals. (ASHRAE 2009) Because these simplified one-dimension calculations do not take into account any thermal bridging, these values were used as the “baseline R-value” in our research as the best case scenario. It follows, that assemblies whose observed and simulated R-values



were similar had minimal thermal bridges. If there was a larger discrepancy between the hand-calculated, simulated R-value and observed R-value, thermal bridging was generally found to be playing a significant role in decreasing the thermal performance of the assembly.

In Field Observations

In order to understand how façades are performing in the field, we used a thermal imaging camera to locate areas of reduced performance and then determine the actual R-value of the area in question. Because we had access to a wide variety of common commercial envelope types and would similarly have access to the as-built detailing and materials submittals, we limited our investigation to projects that had been designed by our firm.

Two-person teams were deployed to 15 buildings and were asked to assess the general envelope thermal performance as well as scan the building envelope for areas that appeared to be performing differently. Because errors in calculating the R-value with the camera are minimized when the outdoor-to-indoor temperature difference is the largest, the teams went out to take measurements on cold days where the average outdoor daytime temperatures were less than 40°F. Care was taken to avoid façades that were currently, or had recently been, in direct sun or were subject to internal heat sources or other factors that would skew results.

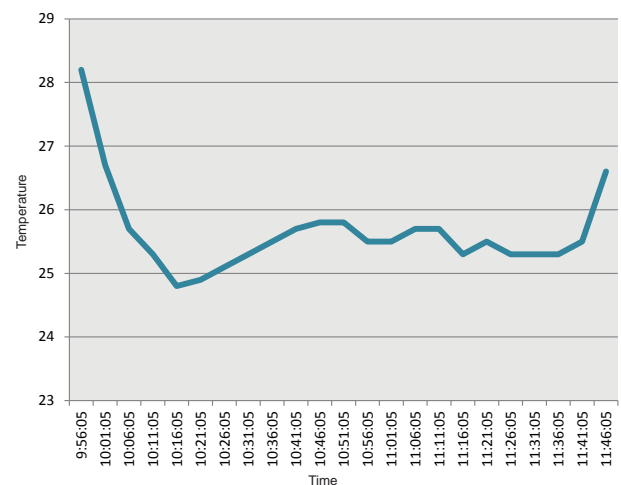

Example of external temperature data logger

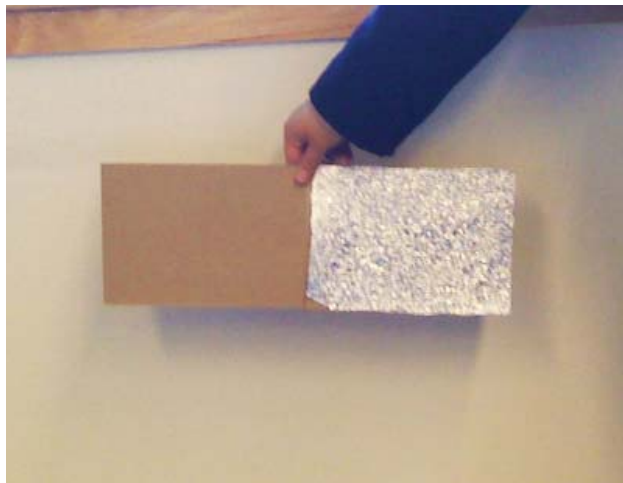
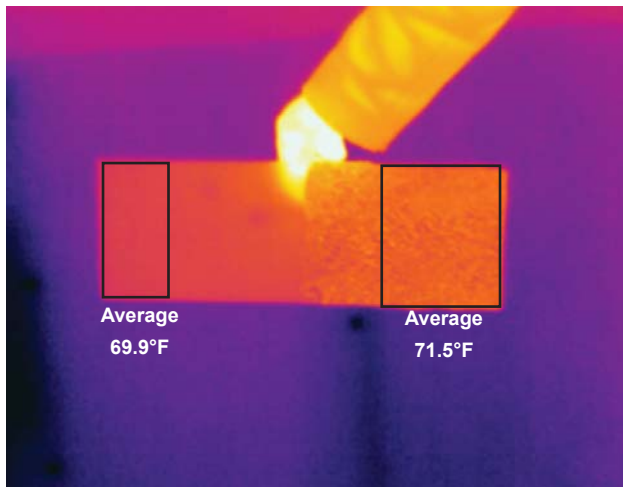

Images of cardboard and aluminium foil tool used to determine air and radiant temperatures

After collecting all of the field information, the research team reviewed more than 1,300 thermal images. These were considered relative to our Contract Documents in order to identify the conditions that were most directly tied to thermal bridging issues as opposed to construction defects. This process served to eliminate problem areas such as missing insulation or air infiltration through discontinuities in air/vapor barriers (though it may be fair to say that infiltration could also be a factor in decreasing the thermal performance).

Using the methodology tested by Madding (2008), we gathered the exterior air temperature, interior air temperature and the radiant temperature in order to calculate the as-built R-value of the assembly. The interior surface temperature of the façade was obtained from the infrared image, while simultaneously, a temperature data logger recorded the exterior air temperature. Using the time stamp on the thermal images, we were able to select the corresponding outdoor temperature with the infrared image.

To obtain the interior air temperature we fanned a piece of card stock for a few minutes, to bring it to air temperature, and then photographed it with the thermal imaging camera. Half of the card stock was covered in crumpled aluminum foil so that it would reflect the radiant temperature as well. This is possible because aluminum foil has a very low emissivity; it acts as a heat mirror and reflects the radiant temperature of the surface it is facing.

The air film is based on convective and radiant heat flow, which can be determined from the exterior air temperature, interior air temperature, radiant temperature, wall surface temperature and interior wall emissivity. The thermal images we took gave us the surface temperature, and because the interior air temperature, radiant temperature, as well as the temperature change across the façade was also known, we could determine the temperature change across the interior air film and the percentage of the total temperature change that represented. Because of this, the R-value of the entire assembly could then be determined. Our researchers used the R-Value Energy Savings Estimator spreadsheet provided by the camera manufacturer to calculate the R-values from the thermal images based on the collected temperatures. (Madding 2008) Using the camera software, we were able to hone in on areas within the thermal image that we were interested in to determine the average wall surface temperature, as well as the average indoor temperature and radiant temperatures from the cardboard and aluminum foil. These three temperatures, as well as the exterior temperature from the data logger and the wall emissivity that was determined by the surface material of the wall from ASHRAE, provided the inputs required for the R-value calculator.

The thousands of images from 15 recently completed buildings were collected and organized by assembly type and noted conditions that were likely to affect performance (i.e., the transition to a foundation wall or adjacency of a window). Having established a library of data that was primarily focused on thermal bridging issues, the research team was able to identify themes based on recurring problematic areas. We noted that they fell generally into two categories: one that is related to the structure that supports the façade and roof systems, and one that is more about material transitions and penetrations. Understanding these categories, we identified a handful of typical conditions that were selected for further investigation and analysis.

	Measured	Parallel Path		Isothermal Planes		Averaged	
	°C	°C	% Different	°C	% Different	°C	% Different
Nylon, 229mm	12.4	11.5	-7.3%	11.5	-7.3%	11.5	-7.3%
Stainless, 457mm	11.0	11.3	+2.7%	10.5	-4.5%	10.9	-0.9%
Stainless, 305mm	10.8	11.2	+3.7%	10.1	-6.5%	10.7	-0.9%
Stainless, 229mm	10.7	11.1	+3.7%	9.8	-8.4%	10.5	-1.9%
Stainless, 152mm	10.5	10.9	+3.8%	9.2	-12.4%	10.1	-3.8%
Stainless, 76mm	9.4	10.3	+9.6%	7.9	-16.0%	9.1	-3.2%
Steel, 229mm	8.8	11.1	+26.1%	7.7	-12.5%	9.4	+6.8%
Average			±8.1%		-9.7%		± 3.5%

Average Surface Temperature Results Comparison of Measured and THERM Simulations (Griffith 1997)

Simulated Performance

Because we would not be able to physically alter the built conditions, our methodology proposed to use computer simulations to test possible improvements to various construction details. We selected the Lawrence Berkeley National Laboratory's THERM program, a 2D heat flow simulator, to determine R-values of complete assemblies including thermal bridges. For each detail, the first step in our process was to prepare THERM models of the constructed designs, which were then calibrated to the actual performance measured in the field with the thermal imaging camera. Because neither THERM nor the camera are a perfect technology, the process of calibrating the simulations with the thermal images allowed us to ensure that the models were accurate representations of what was observed in the field. With a validated THERM model in place, we were then comfortable trying design improvements and comparing the relative performance against the field measured performance.

THERM is a two dimensional heat flow simulator where a plan or section of the envelope area is modeled by defining the conductivity of each material and the surface conductances and temperatures. (Lawrence Berkeley National Laboratory 2011) As with the hand calculations, the values from the 2009 ASHRAE Handbook Fundamentals were used when actual values were not known for various materials. The interior and exterior air temperatures were determined by the actual measurements made at the time of the relevant thermal image.

Because THERM is a two dimensional heat flow simulator, however, it is slightly limited in its ability to consider complex three-dimensional assemblies. It assumes that all modeled elements are continuous into and out of the screen. For discontinuous thermal bridges, such as bolts or clips, two methods were used to account for their three dimensional impact: the Parallel Path method and the Isothermal

Planes method. Because the Parallel Path method tends to underestimate the impact of the thermal bridge and the Isothermal Planes method tends to overestimate its impact (Griffith, et al. 1998), the average of the two methods has been shown to be closest approximation. (Love 2011)

The Parallel Path method uses the weighted average of two simulations, one of the clear wall without the discontinuous

Parallel Path Simulation without Thermal Bridge (R-11.8)

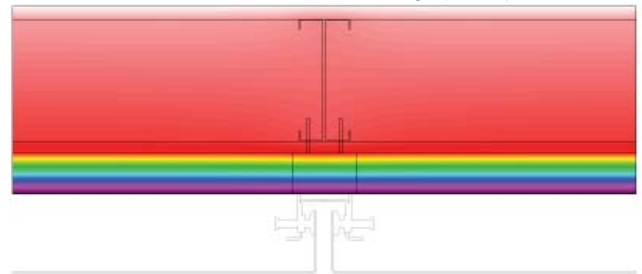

Parallel Path Simulation with Thermal Bridge (R-3.5)

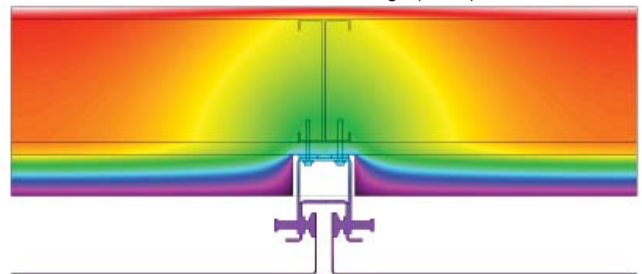

Isothermal Planes Simulation (R-6.2)

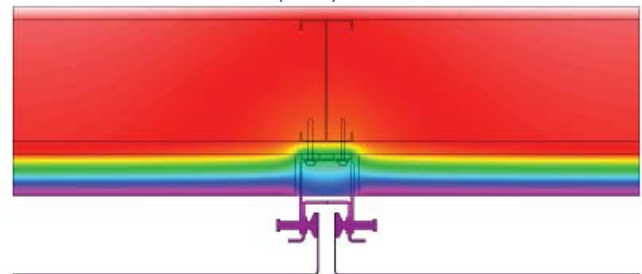

Three THERM Simulations for Discontinuous Thermal Bridges (R-8.7)

element, and the other with the bridging element. A weighted average based on the depth and spacing of the element in the dimension that is not drawn into and out of the screen, is taken of the results from the two simulations. The Isothermal Planes method is performed with one simulation, where a weighted average of the conductivities of the discontinuous bridging element and the clear wall material is used to create a new material with the new conductivity for the discontinuous thermal bridging element. The weighted average is based on the depth and spacing of the discontinuous element into and out of the screen, as with the Parallel Path method.

Once models of the existing conditions were established, we were able to better understand the thermal bridges inherent in the design, and develop alternative details that would improve thermal performance. Working from both the graphical and quantitative output from THERM, we strategically probed the models to identify the significant heat transfer elements within a given detail, and ultimately predict the performance improvements that might result from changes in detailing. This was particularly beneficial in the context of comparing different design options or the benefits of specialty products targeting thermal bridging performance.

Thermal Bridging Area of Investigation : Façade System

Our investigation fell into two categories: façade systems, and assembly transitions. After evaluating our field data, we identified five basic façade types that would be generally applicable to modern commercial and institutional work and

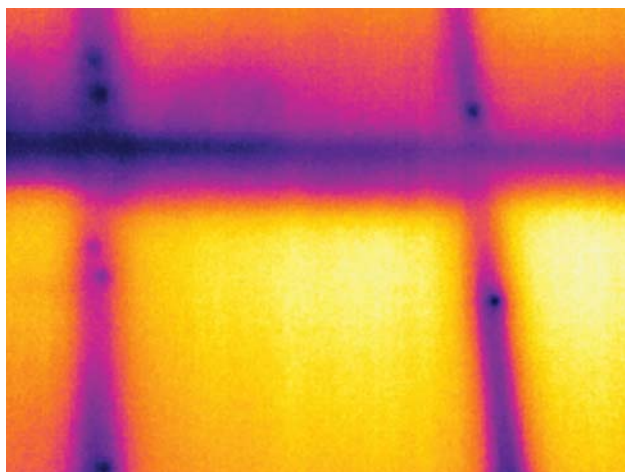

Infrared Image of Z-girt supports at a Rainscreen

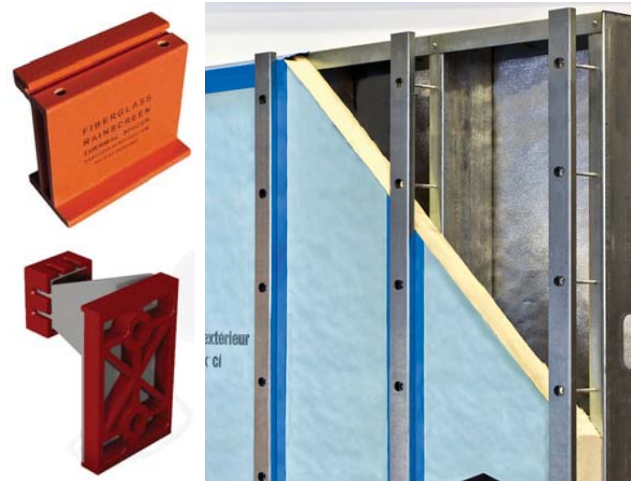

Examples of thermally broken rainscreen supports

appeared to reflect slightly different challenges. These were: rainscreens, masonry veneer walls, insulated metal panels, curtain walls and the renovation of existing masonry façades.

Rainscreens

Rainscreens have become increasingly popular for commercial façades in the past few decades due to their ability to control air and moisture movement. Because the cladding is held off the wall structure to form a drainage cavity while accommodating insulation and a robust air and vapor barrier, these systems require a secondary structural system of rails, Z-girts, and/or clips to support the cladding. Typically made of highly conductive metals, these structural members penetrate through the insulation causing significant thermal bridges. While insulation between steel studs has long been acknowledged in the industry to cause thermal bridging, these rainscreen supports have a similar impact thermally that until recently was widely overlooked.

In our thermal images of rainscreen façades, we observed a decrease in thermal performance that ranged from 20% to 60% less than the design intended performance, with the majority around a 45-55% decrease. The systems we selected for study all had between two to three inches of insulation. We looked at a rainscreen with horizontal Z-girts, vertical Z-girts, and a clip-based system. Not surprisingly, the continuous Z-girts, whether horizontal or vertical, performed similarly. In both orientations, Z-girts demonstrated an R.7.7 reduction in the assembly's R-value or roughly a 45-55% reduction in performance depending on the insulation thickness.

The façade with the clip system for the rainscreen performed much better than those with continuous Z-girts. Because of the intermittent nature of the clips, these systems performed well both in thermal images and in the computer modeling. The clip support system had half of the heat flow of the

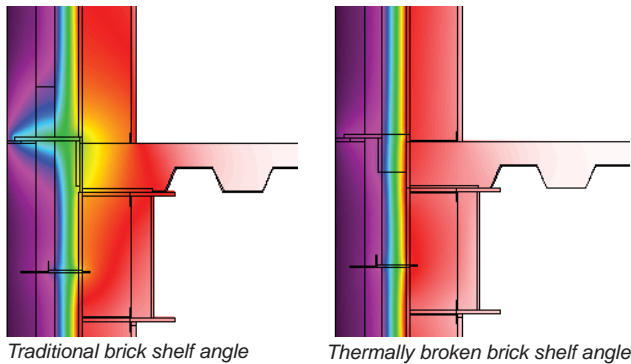

Traditional brick shelf angle

Thermally broken brick shelf angle

Z-girts, or a 25% of the design intent. While the intermittent nature of the support system certainly improved the performance, we investigated ways to further improve the performance of rainscreen support systems.

A number of thermally broken Z-girt and rainscreen support systems currently exist on the market. As part of the research project, the team explored three of the thermally-broken options available. The first removed the support through the insulation with horizontal and vertical tube supports on the exterior and allowed only the stainless steel bolts to penetrate the insulation. The second system investigated a fiber glass clip system. This has the benefit of being intermittent, similar to the previous clip, but also uses a material that is more than 200 times less conductive than steel. The third system investigated was a discontinuous steel bracket with isolator pads on both the warm and cold side of the insulation, in order to minimize heat flow through the brackets. All three of the tested systems performed well. In general the R-value of the assemblies was only reduced by 10-15% due to thermal bridging through their support systems and so they achieved a minimum of R-20 with four inches of insulation.

Masonry Veneer Walls

Masonry veneer wall systems are common for many building types in North America. Because they are rarely load bearing, they are dependent on shelf angles and a grid of tie-backs to structurally stabilize the assembly. Unfortunately, these supports and attachments form substantial thermal bridges that can dramatically decrease the overall thermal performance of the facades. In our observations with the thermal camera, we found masonry veneers generally performed at a 25-60% decrease in R-value when compared to theoretical calculations.

While masonry veneers can be supported without shelf angles by bearing on the foundation for limited heights, continuous shelf angles are typically required to support heights over two stories, and supporting every story is common in order to minimize deflection joints. These shelf angles typically run from close to the face of the masonry back through to the

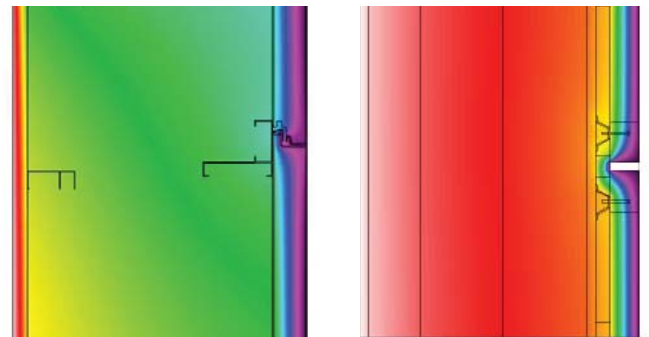

Metal Panel w/ Uninsulated Joints

Metal Panel w/ Insulated Joints

superstructure, passing through the insulation layer. Taken alone, these steel shelf angles account for an approximate 35% decrease in the R-value. That figure would be far worse if the steel was protected with highly conductive coated copper flashing as it may have been several years ago. Today, we might consider using a membrane flashing and making the entire angle out of stainless steel (which has 1/3 the conductivity of carbon steel). This sort of change could reduce the performance impact of the shelf angle from 35% down to 29%.

In order to truly minimize the thermal impact from the shelf angle, however, we investigated an option, advocated by Building Science Corporation (Lstiburek 2008), of supporting the shelf angle with evenly spaced blades or brackets that allow the shelf angle to remain entirely outboard of the insulation, thereby creating intermittent rather than continuous thermal bridges. Providing a thermal break between the brackets and the shelf angle and then conservatively assuming these brackets are spaced at 48" inches on center, results in a substantial improvement in performance. In this system we saw only a 12% decrease in the R-Value from the support structure. This could be reduced down to 3% if the blades were made of stainless steel.

In addition to the shelf angle, metal ties are typically required in masonry veneers to provide lateral support. Surprisingly though these installations are discontinuous, they occur so frequently that they can have a significant impact on assembly R-values. With typical spacing somewhere between 16 and 24 inches on center, horizontally and vertically, ties can contribute up to a 15% decrease in the thermal performance. Because spacing, material conductance, and type of tie all impact the R-value for masonry walls, we looked at a matrix of three types of ties: a screw-on tie, a barrel tie, and a thermally-broken tie. We looked at these options at both 16- and 24-inch spacing in steel and stainless steel. The choice of steel or stainless steel proved to have the biggest impact on performance, with the R-values at an average of 6% improvement, whereas the larger spacing of the ties and the choice of tie type both showed an average of a 4%. Stainless steel ties spaced 24 inches on center, which have minimal

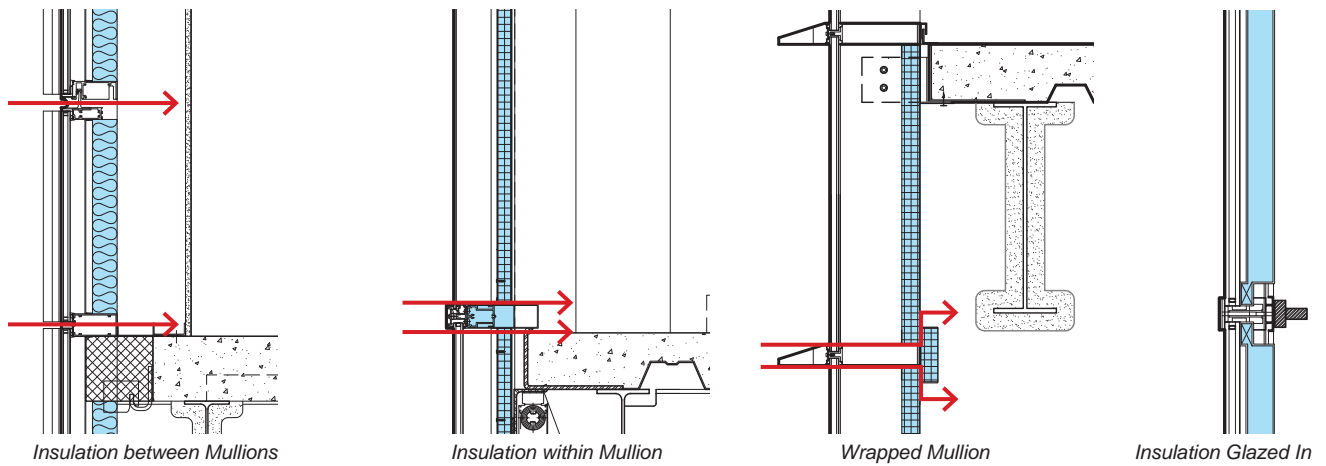

diameter of material penetrating the insulation, were shown to have a negligible impact on the thermal performance, decreasing the R-value by only 2%. Combined with the shelf angle held off by the blades, the thermal performance of masonry veneer façades can be improved substantially from the traditional approach.

Metal Panel Wall Systems

Insulated metal wall panels are popular because they can be a simple and economic strategy for cladding a building. Because the insulation is integral to the cladding and is sandwiched between two metal skins, the cladding support structure does not act as a thermal bridge. However, we observed that the joints between the panels become critical to maintaining thermal integrity for the system. Due to different approaches to the joints, a large discrepancy was observed in the thermal images between the different options, with some at 60-70% less than the baseline R-value and others at only about 3% thermal degradation.

The joints were revealed to be the key difference between metal panels that perform poorly and those that performed well. In the poor performing options, the metal front of the panel wraps through the joint, providing a thermal bridge that greatly undermines performance. The option that performed well, in both the infrared image and the simulation, was backstopped at the gap between connecting panels. The backstop was made of insulation which was wide enough to make a continuous thermal barrier. The simplicity of this joint detail shows how careful detailing can lead to a dramatic improvement in thermal performance.

Curtain Walls

The mullions of curtain walls have long been understood to act as thermal bridges within vision glazing systems. Building codes and other energy standards provide maximum allowable U-values for the whole assembly, accounting for the

frame, the edge of the glass that has been de-rated by the frame and the center of glass performance. In most curtain wall buildings, however, this is only part of the installation. Areas between floors and sometimes across the façade are blanked off to create spandrel panels and these are insulated in a variety of ways. However, because the mullions are simply part of the system, few of us really consider the thermal impact the mullions can have circumventing the insulation. Our thermal images demonstrated that these areas are often substantial sources of heat transfer and the magnitude of the problem is amplified by the density of the mullions and the conductivity of the pieces.

Because curtain wall frames are typically made of highly conductive aluminum, which is about four times more conductive than steel, and go from the exterior of the building through to the interior, they are significant thermal bridges. To combat this, a thermal break in the assembly, which is usually ¼ of an inch to one inch thick and made of a less conductive polyester reinforced nylon, has become a typical component in modern curtain walls. The thermal break is located between the face plate and the structural part of the mullion, the rail, in-line with the glazing pocket. This creates a “cold” side for the portion of the frame in front of the glass, and a “warm” side with the structure on the backside. When insulation is added in a spandrel panel, it is most often added along the backside of the panel, between the innermost surfaces of the rails, and is often supported with a metal back pan. Unfortunately, the insulation creates a “warm” side and “cool” side of mullion rail and completely disconnects the thermal barrier of the insulation from the thermal break in the frame. Observed installations that used this detail, had a 70% decrease in thermal performance.

As the industry has progressed over the past few years, we have become savvier. We did have examples of projects where attempts were made to explore alternative approaches to thermal bridges at spandrel panels. The first option that we looked at included spray foam inserted into the rail in

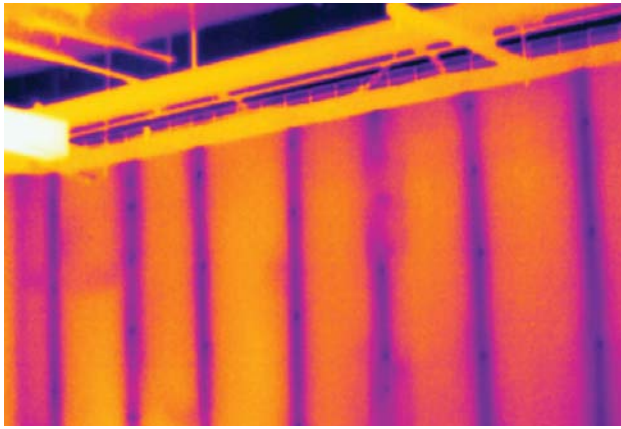

Infrared Image showing studs directly attached to existing wall

an attempt to create a more insulated structural part of the mullion and continuity between the insulation and the thermal break. As might be expected, this showed little improvement over the same rail filled with air, because the heat is conducted by the aluminum, which is unaffected by the insulation inside the frame. The resulting assembly still reflected a 60% decrease in the thermal performance.

The second alternative added a two-inch thick by six-inch tall band of insulation along the back side of the curtain wall rails. This created the promise of a continuous thermal barrier on the backside of the assembly. However, because the rigid insulation is flammable and subject to damage, it included a metal backpan and that was wrapped around the sides and attached to mullion frame. Much like the case of the insulated mullion, the metal pan created a continuous path from warm to cold and though it was very thin, provided an efficient path for heat loss. This too showed a 60% decrease in thermal performance. In our modeling we determined, however, that if the metal pan was removed from the assembly and the insulation could be held in place by a non-conductive material, the thermal performance decrease could be reduced to only 17%.

Though it involved a less conventional, and more expensive curtain wall, the last detail studied was a structurally glazed steel frame curtain wall with triple glazed insulating glass units. Because this system inherently keeps the mullions in-board of the glass, it restricted thermal bridges even for spandrel conditions. The spandrels saw an approximate 30% reduction in the R-value over theoretical calculations and the spandrels achieved an R-15 for the assembly.

Insulating Existing Buildings

Spray applied insulation is gaining popularity, particularly because of its ability to fill unseen voids and provide an integral vapor barrier. In the northeast, it is a particularly popular technology for renovating existing, uninsulated

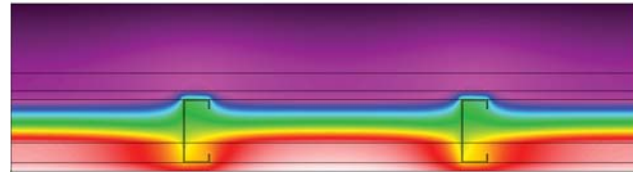

*Studs directly attached to existing wall
59% of baseline calculated R-value*

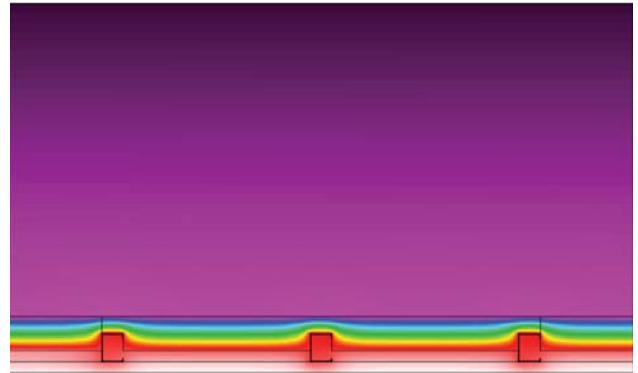

*Studs pulled 1" back from existing wall
16% of baseline calculated R-value*

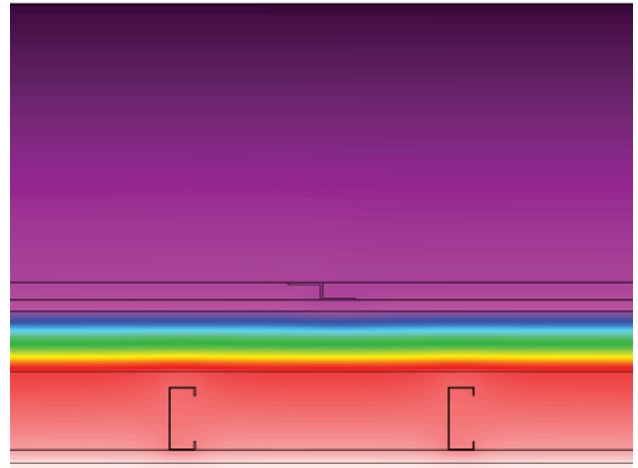

*Studs separated from insulation
2% of baseline calculated R-value*

masonry and cast in place concrete facades. Conventional details often call for metal studs to support interior gypsum board and these studs live in the same space as the insulation, creating discontinuities at 16" or 24" center spacing. While the web of the steel studs is quite slender, they are highly effective heat transfer devices because of the conductivity of the material and the flanges, which provide significant contact area to collect and disperse heat.

Thermal images of the renovation of three separate existing buildings revealed dramatically different results. The first case, had applied 3" of insulation, the second employed just 2" of insulation, and third used 3.5". While hand calculations of the thermal resistance would show the façade with the least insulation to be the weakest performer and the one with the most insulation to be the best, the thermal images revealed a different story. The 3" of insulation included steel

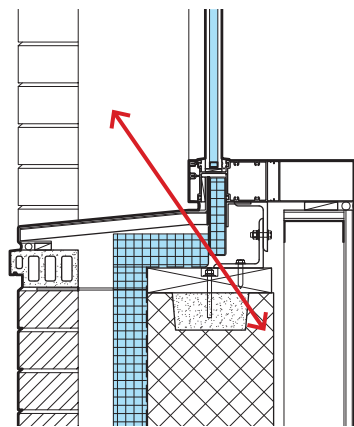

Window recessed from insulation

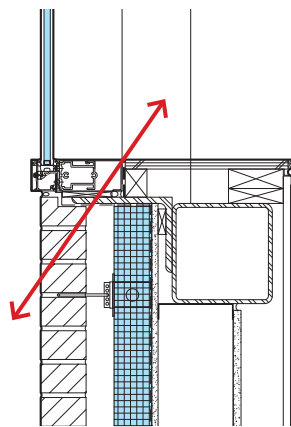

Window proud of insulation

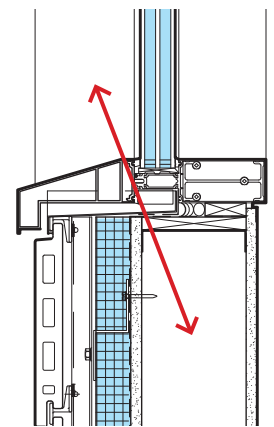

Window in-line with insulation

studs flush against the exterior construction, resulting in an R-value that was 55% less than the calculated R-value. The second building pulled the studs back by 1", allowing for half of the applied insulation to be continuous and decreasing the R-value by only 15%. Consequently, that façade was observed to have a higher R-value than one with the studs penetration through to the exterior, despite having less insulation. The third façade took the studs back even farther, completely separating them from the insulation and as a result the simulated R-value was nearly identical to the measured values.

Our study showed that the continuity of the first inch is critical to the efficiency of the spray foam insulation performance. By simply pulling the studs in-board, even by a small amount, to allow a percentage of the insulation to be uninterrupted, the assembly R-value can be increased by about 70%. In the event that the studs are required to support exterior sheathing, it should be possible to fasten the sheathing using discontinuous and non-conductive shims or spacers so that, once again, the majority of the insulation in that outer 1" layer remains continuous. Nevertheless, small changes in the design can still lead to dramatic improvement in performance.

Thermal Bridging Area of Investigation: Transitions

Where façade systems seem to be good candidates for systemic improvements that might be universally applicable, assembly transitions appear to be more project-specific. Our research did show, however, that certain themes seem to recur in the design of intersecting materials and knowledge of those themes will likely lead to improved detailing even in highly-customized scenarios. In our investigation we found the most thermally problematic conditions at window installations, foundation-to-wall transitions, changes in wall systems, soffits, roof-to-wall transitions, parapets,

roof penetrations, louver openings, existing buildings with embedded beams and slabs, and seismic and movement joints. As with the façade systems, we used thermal images and computer simulations to study these areas and seek potential paths for improvement.

Window Transitions

In terms of thermal performance, windows have long been known to have inferior thermal performance to walls, but it is not as widely known that thermal bridges associated with their installation also derate the performance of the surrounding wall systems. For this research, we focused on window transitions and how they impacted the adjacent thermal barrier. The loss that occurs around a window, typically through the structural components in the wall, is called flanking loss (Lstiburek 2011). The poor performance of the area directly surrounding the window assembly was caused by both the structural requirements for supporting the window and the difficult transition of the various materials that create thermal, moisture, and air barriers. These problems are exacerbated when the design calls for the windows to move in and out of plane with the main thermal barrier of the wall system.

When a window assembly is set back from the thermal barrier, for example, an additional level of complexity is added to the detail. The thermal barrier must maintain continuity as it transitions to the mullion, but in many cases, when a window is recessed, the structure supporting the window and often the wall, gets in the way of continuous insulation. In our study we noted the façade area adjacent to a recessed window to have an approximate 60% loss in thermal performance and this was directly tied to steel angles and other miscellaneous metals that were used to transfer loads associated with the window and its opening.

The thermal performance of window assemblies that are

pushed towards the exterior of the envelope can be similarly complex because the thermal break in the frame typically sits toward the front of the assembly, and therefore requires complex horizontal connections. Because the whole assembly tends to be proud of the main insulation line of the building, there is a tendency to expose the sides of the window frame and induce flanking loss directly through the mullions. Of course this can be mitigated by wrapping the frame with insulation, but this leads to a thick profile around the glazing unit which is not usually consistent with the visual intent of the design.

Beyond the flanking losses of the mullion, windows that are proud of the superstructure can be more challenging to support vertically. Generally the cantilevers associated with such an assembly are heavier and more complex than a more traditional installation and these lead to more frequent and heavier thermal bridges. Similar to the recessed windows, we saw an approximate 60% reduction in R-value of walls immediately adjacent to windows of this type.

When we consider the detailing complexities associated with moving insulation layers into and out of plane, it appears that keeping windows in line with the main insulation line of the building is the configuration most likely to avoid difficult thermal bridges. Even so, however, we noted that conventional window installation can still fall prey to the challenges introduced by framing and support. In some tests we saw conventional installations that were still seeing a 45-60% decrease in the R-value in the vicinity of windows. These reductions were directly attributed to issues such as blocking, flashing, and other insulation interruptions at the window perimeter.

Understanding the challenges of these sorts of installations, we studied several approaches to mitigating flanking losses while still trying to preserve minimal sight lines around window openings. The underlying goal of these approaches was to develop a continuous line of insulation that tracks to the thermal break within the window frame. In one promising concept, we proposed glazing an insulated metal panel into the mullion pocket around the perimeter of a recessed window. This resulted in a 20% reduction in heat flow through the assembly over the more traditional installation.

In addition, it is clear that whenever the façade requires structure to move in or out of plane with the main

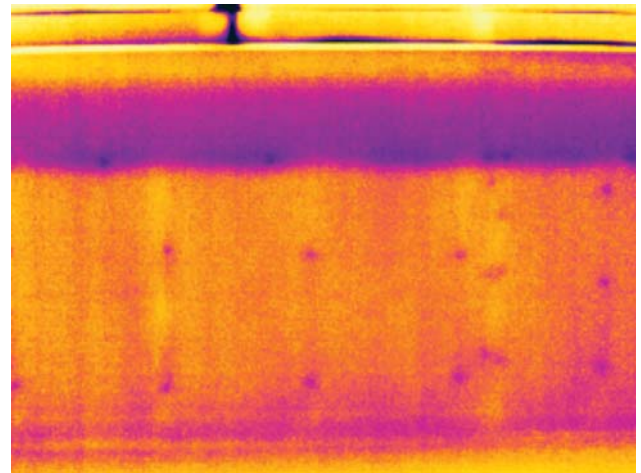

Infrared image of structural support at window proud of insulation

superstructure, this will lead to substantial performance impact.

It is essential to avoid continuous support and assure that outriggers or brackets are used to create only the bare minimum number of thermal bridges. In one test case, we replaced a continuous section of tube steel with intermittent blades that cantilevered out to support a brick lintel and effected a 68% reduction in heat flow through the assembly. While our study was typically based on brackets spaced at 48" +/- on center, it should also be possible to increase spans well over 96" to realize far greater performance (at the expense of heavier structure).

Foundation to Wall Transitions

The wall transition above the foundation wall is consistently a problematic area for thermal performance. This transition has been observed to affect the wall R-value by as much as 70-75% for three factors. The transition of wall assemblies is usually necessary because most wall assemblies above grade are not able to withstand conditions below grade. The switch of wall assemblies usually results in an offset and discontinuity of the insulation. The second reason this is a difficult area to detail is that this offset typically occurs at the termination of waterproofing which results in the metal flashing spanning across the insulation, creating an additional thermal bridge. The third factor to take into account is that the transition often occurs where the slab on grade meets the foundation wall. The structural stability of the connection creates another discontinuity of the insulation that is hard to overcome.

To determine ways to improve the performance we looked at a number of options for improved details. The first was a structural thermal break in the concrete slab where it connects

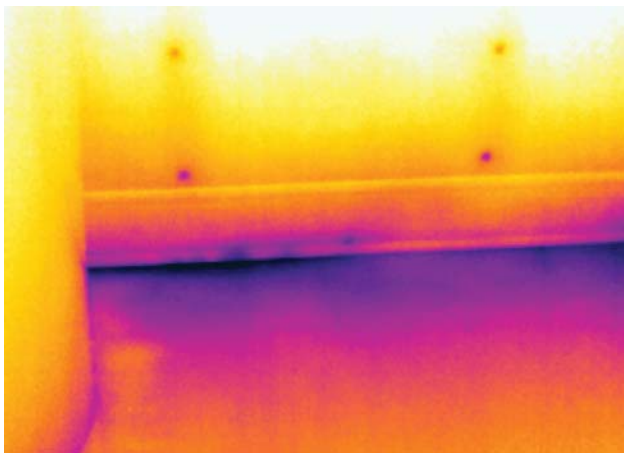

Infrared image looking at the foundation wall transition

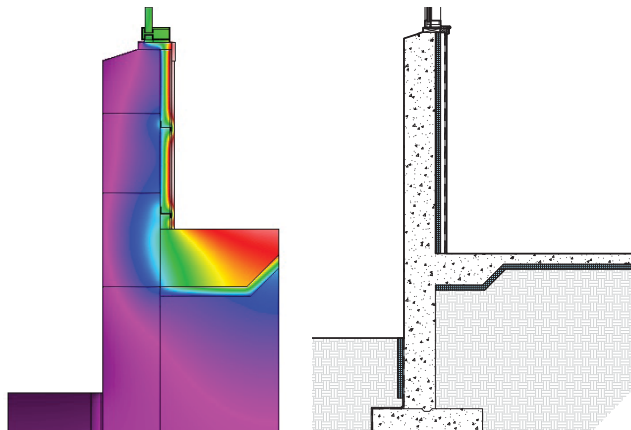

THERM Simulation and detail of the foundation wall transition

to the foundation wall for a foundation wall that was insulated on the interior. This allows for some thermal continuity between the slab insulation and the interior insulation. The most improved option was a concrete foundation wall built of a sandwich panel with insulation integral within the concrete. This allowed the insulation to be as continuous as possible with the above grade insulation, and minimizes the shelf condition at grade.

Transitions between Wall Systems

Just as thermal bridging was observed at the foundation wall transitions, when there are multiple façade systems employed thermal bridges have been observed at the interface between systems. Common sources of loss were observed because of the complexity introduced due to two systems coming together and the challenge of maintaining the thermal barrier across the transition. In these interfaces the decrease in the R-value was observed to range between 50-80%.

Improved details were developed with the goal of limiting the complexity, aligning the insulation between systems and the minimizing the amount of systems transitions were seen to improve performance. As with most façade systems, careful

attention should be paid to how systems are supported at the perimeter.

Soffits

Envelope transitions from vertical systems to horizontal ones and then back vertical again require complex support structures that are well known to complicate air and vapor barrier installations, and often lead to complex thermal bridges that are difficult to eliminate elegantly. When looking at comparatively small areas such as a soffit, these complex assemblies take on a disproportionate role in the area of the assemblies in question and so when they are evaluated on their own, the R-value of the assembly adjusted for thermal bridges can be quite low. Beyond just the structural complications of beam to column interfaces, these sorts of assemblies usually include material transitions which will often require blocking or other accessory installations for anchorage and fastening. Considering soffits in particular, we observed R-values with a 35-70% reduction in performance over baseline.

To improve the performance of soffits, we studied a number of different potential improvements. As with other envelope conditions, we looked at minimizing continuous elements such as Z-girts with intermittent stand-off bolts, or using non-conductive materials such as fiberglass. These strategies were found to increase R-value of the soffit by 65%. Additionally, while typically, we find that structure is best when kept on the warm side of the insulation, soffits may prove to be an area where this is not quite as clear due to the complexity of holding up the exterior face of the soffit. If the material is inherently insulative, such as a metal foam panel, this issue will not present itself, but otherwise, it can be advantageous to concentrate the structural thermal bridges in a few, carefully planned penetrations of the insulation system and then treat all of the soffit construction in much the same way as we would a rainscreen.

Roof to Wall Transitions

Transitions from roofing systems to a wall systems, which occur when building massing steps back at upper floors, pose similar challenges. We found the continuity of the thermal barrier was often compromised in typical detailing due to flashing, blocking, and structural supports. In the infrared images taken, many were noted to have a 40-75% decrease

in the R-value in areas where this transition occurred. Some of these installations demonstrated that more aggressive detailing readily addressed the problem. Because gravity assists in the performance of these systems (unlike soffits) the structural complexities associated with changes in direction can be mitigated easily and with careful attention, we can minimize blocking and control fastener placement, and select non-conductive flashing materials minimizing thermal bridges.

Parapets

Another location where the wall interfaces with the roof is at the top of the building where there is often a parapet. Using common construction techniques, these unique assemblies typically maximize envelope surface area near a complex interface which can have the impact of emphasizing the effect of a thermal bridge and increasing heat flow. Unfortunately, it is rarely possible to effectively photograph these conditions from the inside and quantify the assembly R-values in the field with an infrared camera. Knowing this was an issue for heat loss, however, we were still able to perform simulations and study the impact of changes.

We found that the structure required to support the parapet, whether it is concrete or cold form metal framing, typically leads to a considerable gap between the façade insulation generally on the exterior of the parapet and the roof insulation which runs on the interior. Furthermore, wood nailers, cant strips and other roofing accessories tended to exaggerate these impacts.

One question we found intriguing was whether it was

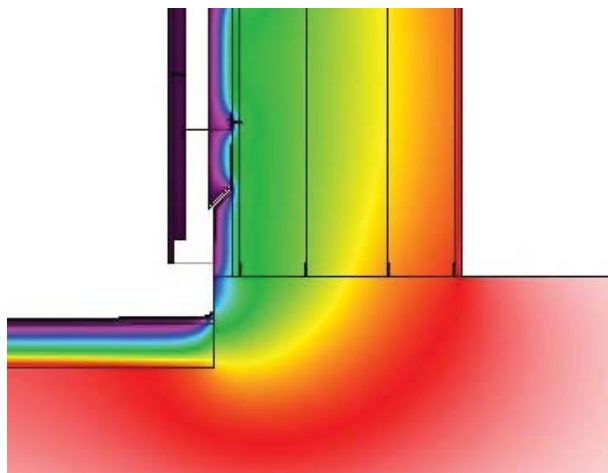

THERM Simulation of roof to wall transition

better to insulate around the parapet thereby covering all structural interfaces, or underneath it by finding a way to design a structural connection that effectively attaches the parapet after installation of the insulation. Since there are many variables in the detailing of a parapet, we started with a sensitivity analysis of parapet height normalized to one construction type. Because the degree of impact of the assembly depends on how much of the building we are looking at in conjunction with the parapet, we also normalized on an extracted detail that includes 24" in height of inside wall surface and 48" in length of inside roof surface. These were based off the Morrison Hershfield (Morrison Hershfield 2011) report's findings on the effective length that a parapet affects the heat flow in these assemblies.

Starting with a well-insulated parapet, the study into the impact of height showed that there was about a 6% decrease in assembly R-value for every 15" increase in the parapet height. This is due simply because the additional surface area acts like a fin that radiates. Considering these results, we concluded the best way to avoid a diminishing R-value is to insulate beneath the parapet, thus effectively eliminating the negative impact from the height of the parapet.

Moving into greater detail, we also studied typical construction methods for parapet systems. Considering cold formed metal framing parapets and cast-in-place concrete assemblies, we found that R-value were reduced from a theoretical system 63% and 50%, respectively. This decrease in thermal performance was largely due to the large gap in insulation that occurred at the parapet. We also studied a third case where a cold formed metal framing parapet had been installed

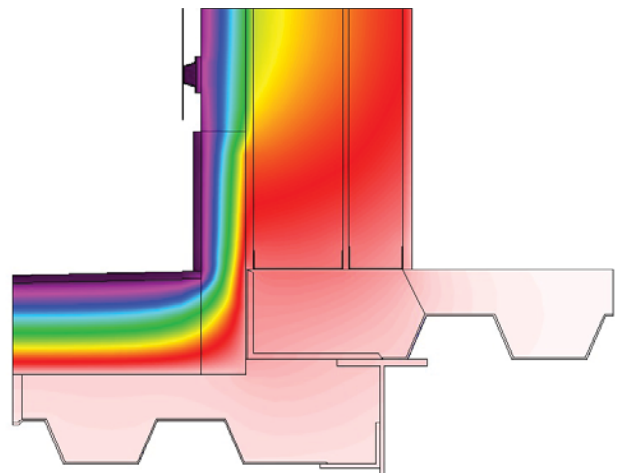

THERM Simulation of roof to wall transition with continuous insulation

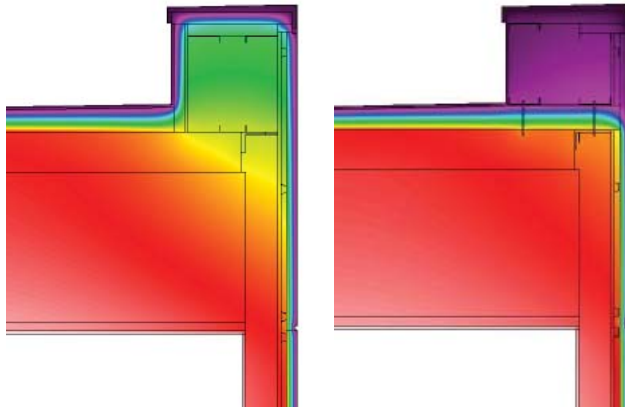

THERM Simulation of parapet: insulating around(left) versus insulating under the parapet(right)

over continuous insulation, however, that design had relied on metal kickers which we found virtually eliminated the performance gains.

We studied two systems for improving the typical details. The cold formed metal framing option had continuous insulation under the parapet to the façade insulation to create a continuous thermal barrier. To support the structure of the parapet, we added a metal framing structure and included intermittent connection back to structure using lower-conductivity materials such as stainless steel bolts. This increased the R-value in the assembly by 25-65% when compared to the baseline system. For the concrete parapet, we tested a commercially available structural thermal break designed for concrete slabs (balconies) and installed this in a vertical orientation. This improvement decreased the heat flow through the assembly by 27%.

Roof Penetrations

By their very nature, roofs present a large number of challenges in terms of maintaining a continuous thermal boundary. While roof drains, plumbing vents, and the like may be unavoidable and largely immutable, the impacts of other penetrations can be minimized through careful detailing. As part of our exploration, we considered skylights, balcony railings and roof davits as common conditions.

Skylights are generally recognized to have inferior thermal performance, and this is demonstrated through the fact that energy codes allow significantly higher U-values for skylights than windows. Because they frequently omit thermal breaks in the frame and larger openings typically require additional structure, there is significant thermal loss around the perimeter of traditional skylight installations. Additionally, for drainage reasons the thermal barrier of the insulated glazing unit in a skylight typically protrudes above the roofing assembly, and just as with vertical windows that are proud

of the façade, this requires more complicated detailing to try to maintain a thermal barrier. Wrapping the skylight frame in an insulated metal panel and ensuring thermal continuity throughout the skylight support dramatically improves its thermal performance.

On roofs that require access, railings and the structure required to support them can create substantial thermal bridges. At one building that we studied, there was a continuous bottom rail of an all-glass railing that was supported by steel tubes down to the slab below. Because the tubing interrupted the insulation, this sort of installation duplicated the typical conditions we expect to see with a continuous relieving angle on a brick veneer wall. By changing the material of the bottom rail to stainless steel and introducing a thermal break between the rail and the steel supports, we were able to minimize thermal bridging. Our modeling showed that such an approach reduced the heat loss through the assembly over 50%.

Roof davits and other structural elements like roof dunnage present a similar challenge. These often penetrate through the roof to be connected directly to the building superstructure. While these individual occurrences may be so small that they have no significant impact total heat loss, we found they are often worth considering in humidified environments due to the threat of condensation. Looking specifically at davits, we considered several directions for improvement. To begin with, we proposed to cover the exterior of the davit with an insulated “sock” that could be removed when in use. However, because the steel of the davit is still penetrating from outside to inside the thermal barrier, the improvement in interior surface temperatures was minimal. Creating a structural thermal break with two steel plates (one on either side of the insulation) led to significant improvements, however.

Mechanical Louvers

Another area in the exterior envelope system where the continuity of the thermal barrier can often be lost is around the opening for mechanical louvers. The thermal loss around louvers, though not as significant as other thermal bridges studied, seem to primarily be a resultant of drawing coordination and construction sequencing. Because the insulation of the plenum is most often shown on the mechanical drawings and the wall system on the architectural

drawings, details are frequently not coordinated to show the thermal continuity through the detail. The mechanical plenum drawings stop at the interior side of the wall, whereas the architectural drawing set most often shows the insulation remaining on the plane of the exterior, leaving a gap in the building envelope between the two systems. Coordinating drawings to show continuity of the thermal barrier from the envelope through to the mechanical plenum will improve the thermal performance around louvers.

In addition to the thermal bridges caused from the discontinuity between mechanical and architectural drawings, if a plenum is built sitting on the floor of the mechanical room, it often is uninsulated at this location. Louvers that can instead be supported intermittently to allow for the thermal barrier to pass across the envelope system with minimal thermal breaks will considerably improve thermal performance.

Beam Embeds in Existing Buildings

Since existing buildings are typically insulated from the interior during a renovation, the structural members can cause substantial thermal bridges. In load bearing masonry buildings, common in the Northeast, the bearing support for beams are often embedded in the exterior wall causing the steel beam to penetrate the insulation and causing a significant thermal bridge. This was observed in thermal images to decrease the thermal performance of the adjacent wall by 72% in thermal images. In photographed details, Teflon spacers had been used where the angles connected the embedded steel to the beam web. Because the beam was still extending through the insulation, the spacers which were intended to lessen the thermal bridge from the beam did not have a significant impact.

While existing beams pose a difficult challenge to improving this condition, when new structural beams are added as part of the renovation, there is an opportunity to improve the façade's thermal performance. An alternative option was investigated that employed a structural thermal break at the thermal barrier of the envelope. Many manufactures have thermal breaks for structural steel connections, however because structure typically needs to be fire rated, careful review of the thermal break options is needed as only a few met both the thermal and fire rating requirements for the connection. The thermal break can be coated in cementitious

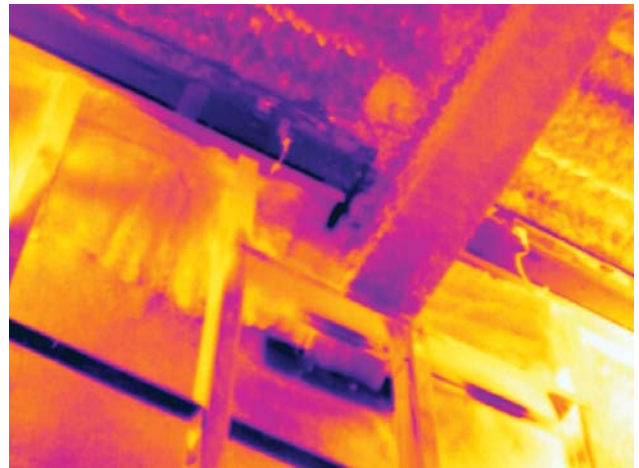

Infrared image of beam connection at existing wall

fire-proofing spray along with the rest of the steel and placed in-line with the insulation to reduce the heat flow around the surrounding assembly by 36%.

New Slabs in Existing Buildings

Similarly to the embed beams, a floor slab will cause a significant thermal bridge since the renovation of existing buildings typically add insulation from the interior that spans from the top of the slab to the bottom of slab. The slabs decrease the R-value of the assemblies by approximately 45%. There may be little that can be done for existing slabs being insulated from the interior, however when a new slab is being added to an existing structure there is an opportunity to thermally improve the performance. By holding the edge of the new slab approximately 5" apart from the back of the existing wall a gap is created that can be infilled with compressed mineral wool in an insulating fire-stop detail. The bolts connecting the slab to the exterior wall are still thermal breaks, however this strategy did improve the R-value 31%.

Seismic & Movement Joints

Observations with the infrared camera revealed that seismic and movement joints present significant thermal bridges. R-values of R-2 to R-6 were seen, a substantial decrease from the design intent and the rest of the envelope assembly.

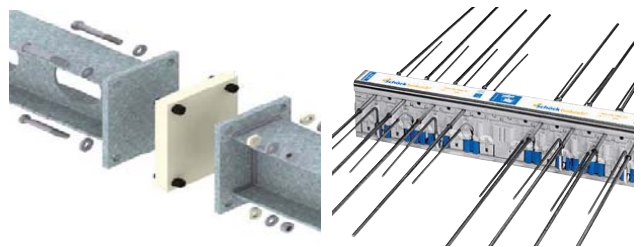

Structural thermal break connection examples

By adding insulation to the front and sides of the joint, the R-value of the assembly was seen to be raised to an R-11.5, which is closer to the clear wall R-values for the adjacent assemblies.

Conclusion

Both the thermal images and simulations in our research reveal that thermal bridging is significantly decreasing the thermal performance in commercial envelopes. While this study is by no means intended to be a comprehensive survey of all thermal bridges, it does illustrate some of the numerous thermal bridges that exist, both systematic ones repeated ubiquitously around the façade as well as more idiosyncratic conditions that further undermine thermal performance. The study also shows how careful detailing and attention to the issues of thermal bridging can dramatically improve the thermal performance.

When designing building envelopes, the continuity of a thermal barrier universally across the building envelope is the key to good thermal performance. When maintaining the continuity of insulation is not feasible, designers should evaluate options to minimize the impact of these thermal bridges. The first priority should be to eliminate continuous conductive elements, such as Z-girts or masonry shelf angles, by pulling them out of the thermal barrier and using discontinuous supports to make required connections. Secondly, utilize available thermally broken products to disconnect the heat flow through the thermal barrier. For those discrete elements that need to puncture the insulation, employ less conductive materials to minimize heat flow through those elements. For example, stainless steel has 1/3 of the conductivity of regular steel and fiberglass's conductivity is significantly lower than stainless. Employing these simple principles can significantly improve the thermal performance of our building envelopes.

More awareness and education is needed within the building industry on the impact of thermal bridging, so designers become aware of the necessity to focus on careful detailing and specifications to combat them. Additionally, there should be a shift in the discussion from the R-value of the insulation that is specified to the R-value of the assembly as designed. Solely focusing on the number of inches of insulation does not give an accurate picture of the thermal performance of the envelope. Free and accessible tools, such as THERM, are

available to enable design teams to evaluate the performance of complex details that cannot be intuitively understood.

Small changes in designs can still lead to dramatic improvement in performance. With careful detailing and attention to the issues of thermal bridging, the design and construction industry can improve the performance of our building envelopes.

References

- ASHRAE. *2009 ASHRAE Handbook Fundamentals*. Atlanta, GA: American Society of Heating, Refrigerating and Air-Conditioning Engineers, Inc., 2009.
- ASHRAE. *ANSI/ASHRAE/IESNA Standard 90.1-2010 Energy Standard for Buildings Except Low-Rise Residential Buildings*. Atlanta, GA: ASHRAE, 2010.
- Griffith, Brent, Elizabeth Finlayson, Mehrangiz Yaz, and Dariush Arasteh. "The Significance of Bolts in the Thermal Performance of Curtain-Wall Frames for Glazed Facades." *1998 ASHRAE Winter Meeting*. San Francisco, CA: ASHRAE, 1998.
- Lawrence Berkeley National Laboratory. *THERM 2.0 for Analyzing Two-Dimensional Heat Transfer*. Berkeley, CA: Regents of the University of California, 1998.
- Lawrence Berkeley National Laboratory. *THERM 6.3 / WINDOW 6.3 NFRC Simulation Manual*. Berkeley, CA: Regents of the University of California, 2011.
- Love, Andrea. *Material Impacts on Operational Energy Usage*. Masters Thesis, Cambridge, MA: Massachusetts Institute of Technology, 2011.
- Lstiburek, Joseph. *BSI-005: A Bridge Too Far*. Building Science Insights, Building Science Corporation, 2008.
- Lstiburek, Joseph. *Thermal Bridges Redux*. BSI-062, Building Science Corporation, 2011.
- Madding, Robert. "Finding R-Values of Stud Frame Constructed Houses with IR Thermography." *Inframation 2008 Proceedings vol. 9*. Reno, 2008.
- Morrison Hershfield. *Thermal Performance of Building Envelope Details for Mid- and High-Rise Buildings (ASHRAE 1365-RP)*. Atlanta: ASHRAE Technical Committee 4.4, 2011.

Image Credits

- Cascadia Windows & Doors
- Euda Wilde
- Fabreeka
- Knight Wall Systems
- Payette
- Schock
- Thermomass
- Warren Jagger

APPENDIX

01 RAINSCREENS	pg 2a	08 TRANSITIONS BETWEEN WALL SYSTEMS.....	pg 74a
a.) Vertical Z-Girts		a.) Curtain Wall to Stone Veneer Base	
b.) Clips		b.) Stone Veneer to Curtain Wall	
c.) Horizontal Z-Girts			
d.) Thermally Broken Support System		09 SOFFITS.....	pg 78a
e.) Thermally Broken Clip		a.) Soffit at Rain Screen Wall	
		b.) Soffit at Metal Panel Wall	
02 MASONRY WALLS.....	pg 14a	c.) Soffit at Stone Cladding	
a.) Masonry Brick Tie Comparison			
b.) Masonry Shelf Angle Comparison		10 ROOF TO WALL TRANSITIONS.....	pg 84a
c.) CMU Back Up Wall with Galvanized Ties		a.) Stud Back Up Wall with Insulation and Blocking	
d.) Stud Back Up Wall with Galvanized Ties		b.) Stud Back Up Wall with Continuous Insulation	
e.) Stud Back Up Wall with Galvanized Ties 2		c.) CMU Back Up Wall with Continuous Insulation	
03 METAL PANEL WALL SYSTEMS.....	pg 24a	11 PARAPETS.....	pg 90a
a.) Metal Panel with Insulated Joints		a.) Parapet Height Study	
b.) Metal Panels with Uninsulated Joints		b.) Insulated Metal Panel Stud Wall	
c.) Metal Panels with Continuous Metal Clips		c.) Concrete Wall	
		d.) Masonry Cavity Wall	
04 CURTAIN WALLS.....	pg 30a		
a.) Insulation Between Mullions (Typical)		12 ROOF PENETRATIONS.....	pg 98a
b.) Insulation within Mullion		a.) Roof Davits	
c.) Wrapped Mullion		b.) Hand Rail	
d.) Insulation Glazed In			
e.) Improved Option		13 LOUVERS.....	pg 102a
		a.) Mechanical Louver at Grade	
05 INSULATING EXISTING BUILDINGS.....	pg 40a	b.) Mechanical Louver at Penthouse	
a.) Studs Directly Attached to Existing Wall			
b.) Studs Pulled 1" Back From Existing Wall		14 EXISTING BUILDING BEAM EMBEDS.....	pg 106a
c.) Studs Separated From Insulation		a.) Thermal Break at Structural Connection	
06 WINDOW TRANSITIONS.....	pg 46a	15 NEW SLABS IN EXISTING BUILDINGS.....	pg 108a
a.) Recessed Relationship with Thermal Barrier		a.) Thermal Break at New Slab	
b.) Recessed Relationship with Thermal Barrier			
c.) Recessed Relationship with Thermal Barrier		16 SEISMIC & MOVEMENT JOINTS.....	pg 110a
d.) Proud Relationship with Thermal Barrier		a.) Joint at Masonry Wall and Existing Building	
e.) Proud Relationship with Thermal Barrier		b.) Joint at Curtain Wall and Existing Building	
f.) Inline Relationship with Thermal Barrier			
g.) Inline Relationship with Thermal Barrier			
h.) Inline Relationship with Thermal Barrier			
07 FOUNDATION TO WALL TRANSITIONS.....	pg 62a		
a.) Foundation Wall Transition 1			
b.) Foundation Wall Transition 2			
c.) Foundation Wall Transition 3			
d.) Foundation Wall Transition 4			
e.) Foundation Wall Transition 5			
f.) Foundation Wall Sandwich Panel Study			

APPENDIX- 01a | RAINSCREENS: Vertical Z-Girts

Project Conditions

Location: Eastern Massachusetts
 Date of Thermal Image: 02/20/2012
 Exterior Air Temperature: 37.7 °F
 Interior Air Temperature: 69.9 °F
 Radiant Temperature: 71.5 °F
 Assumed Emissivity: 0.9

Summary of Thermal Performance

Calculated Baseline R-Value: 13.86 -

As-Built Condition

Thermal Image R-Value: 6.19 - 55%
 Simulated (THERM) R-Value: 5.60 - 60%
 Simulated (THERM) R-Value just support connection: 7.20 - 48%

Thermally Improved Condition

See 1c-1e

As-Built Condition

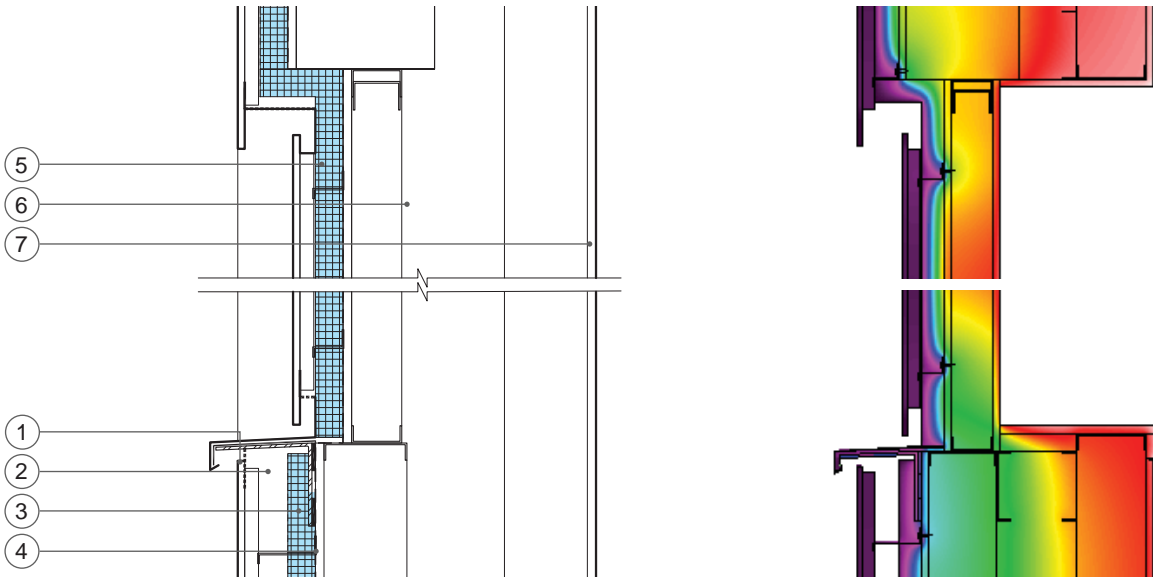

Calculated Baseline Clear Wall R-value									
	Material	Width in.	k Btu-in/h-ft2·°F	R-value h-ft2·°F/Btu		Material	Width in.	k Btu-in/h-ft2·°F	R-value h-ft2·°F/Btu
					(4)	Air & Vapor Barrier	-	-	-
(1)	FRC Panel	-	-	-	(5)	Gypsum Board	0.625	1.10	0.57
(2)	Air Space	-	-	-	(6)	Air Cavity	20	-	1.36
-	Exterior Air Film	-	-	0.68	(7)	Gypsum Board	0.625	1.10	0.57
(3)	Rigid Insulation	2.00	0.20	10.00	-	Interior Air Film	-	-	0.68
								total	13.86

APPENDIX- 01a | RAINSCREENS: Vertical Z-Girts



Digital Image

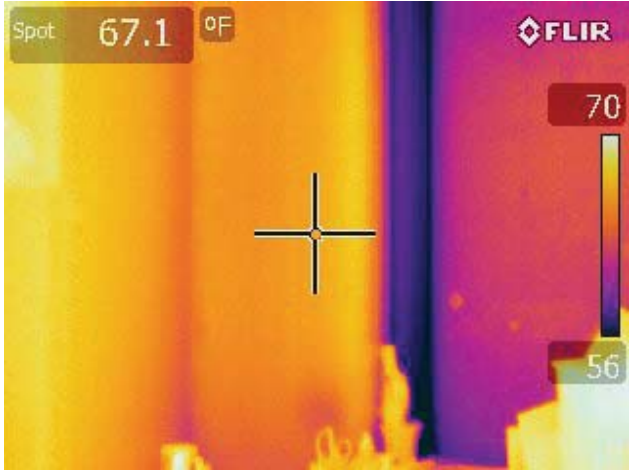

Infrared Image

Detail simulation with only rainscreen support connection

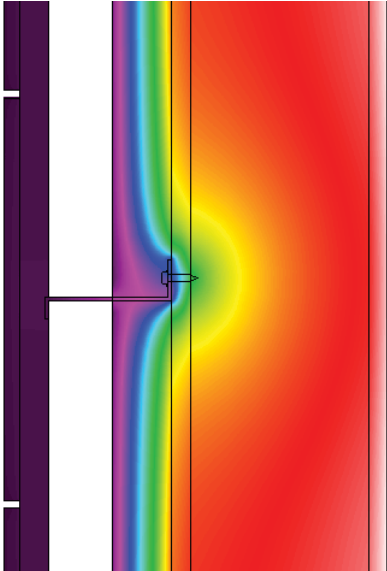

APPENDIX- 01b | RAINSCREENS: Clips

Project Conditions

Location: Eastern Massachusetts
 Date of Thermal Image: 02/09/2012
 Exterior Air Temperature: 34.8 °F
 Interior Air Temperature: 73.8 °F
 Radiant Temperature: 72.3 °F
 Assumed Emissivity: 0.9

Summary of Thermal Performance

Calculated Baseline R-Value: 13.86 -
As-Built Condition
 Thermal Image R-Value: 9.70 - 30 %
 Simulated (THERM) R-Value: 8.66 - 38 %
Thermally Improved Condition
 See 1c-1e

As-Built Condition

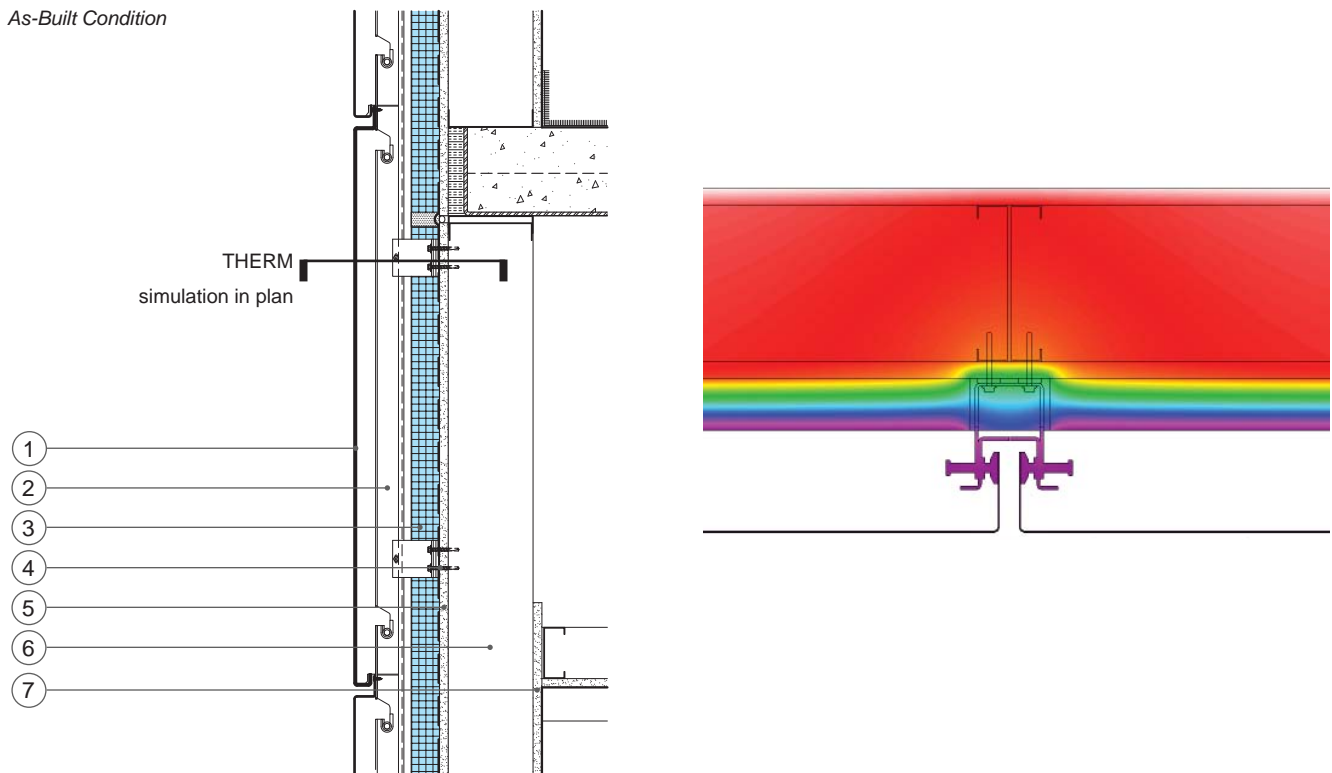

Calculated Baseline Clear Wall R-value									
	Material	Width in.	k Btu-in/h-ft2-°F	R-value h-ft2-°F/Btu		Material	Width in.	k Btu-in/h-ft2-°F	R-value h-ft2-°F/Btu
					(4)	Air and Vapor Barrier	-	-	-
(1)	Aluminum Spandrel	-	-	-	(5)	Gypsum Board	0.625	1.10	0.57
(2)	Air Space	-	-	-	(6)	Air Cavity	6	-	1.36
-	Exterior Air Film	-	-	0.68	(7)	Gypsum Board	0.625	1.10	0.57
(3)	Rigid Insulation	2.00	0.20	10.0	-	Interior Air Film	-	-	0.68
								total	13.86

APPENDIX- 01b | RAINSCREENS: Clips



Digital Image

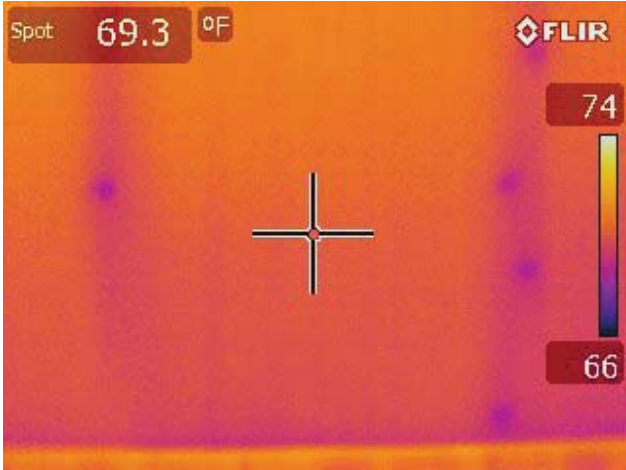

Infrared Image

APPENDIX- 01c | RAINSCREENS: Horizontal Z-Girts

Project Conditions

Location: Eastern Massachusetts
 Date of Thermal Image: 0209/2012
 37.7 °F
 Exterior Air Temperature: 71.6 °F
 Interior Air Temperature: 72.9 °F
 Radiant Temperature: 0.9
 Assumed Emissivity:

Summary of Thermal Performance

Calculated Baseline R-Value: 16.90 -
As-Built Condition
 Thermal Image R-Value: 9.21 - 46 %
 Simulated (THERM) R-Value: 11.05 - 35 %
Thermally Improved Condition
 Simulated (THERM) R-Value: 16.2 - 4 %

As-Built Condition

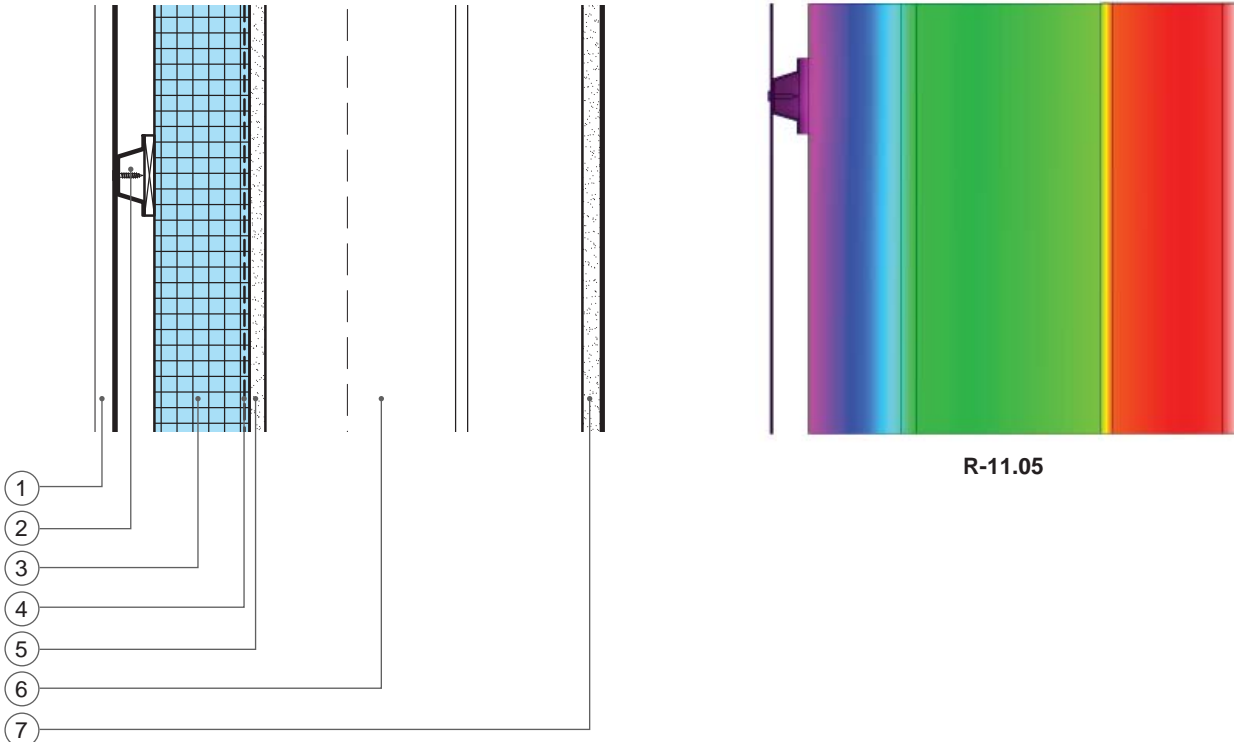

Calculated Baseline Clear Wall R-value									
	Material	Width in.	<i>k</i> Btu·in/h·ft ² ·°F	R-value h·ft ² ·°F/Btu		Material	Width in.	<i>k</i> Btu·in/h·ft ² ·°F	R-value h·ft ² ·°F/Btu
					(4)	Air and Vapor Barrier	-	-	-
(1)	Corrugated Metal	-	-	-	(5)	Gypsum Board	0.625	1.10	0.57
(2)	Hat Channel	-	-	-	(6)	Air Cavity	10.75	-	1.36
-	Exterior Air Film	-	-	0.68	(7)	Gypsum Board	0.625	1.10	0.57
(3)	Insulation w/ Vertical Z-girt	3.00	0.23	13.04	-	Interior Air Film	-	-	0.68
								total	16.90

APPENDIX- 01c | RAINSCREENS: Horizontal Z-Girts



Digital Image

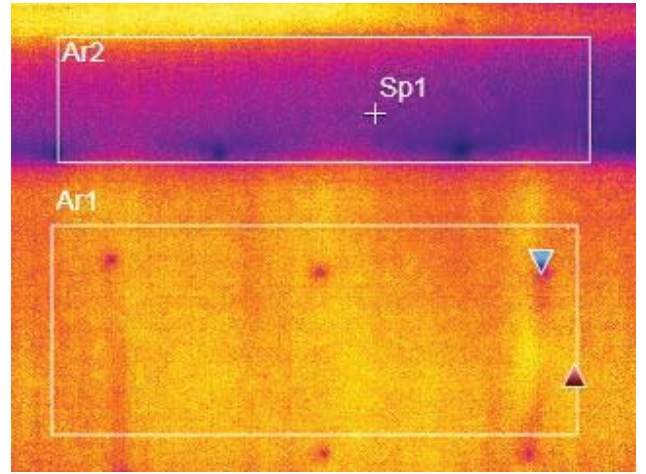

Infrared Image

Thermally Improved Condition

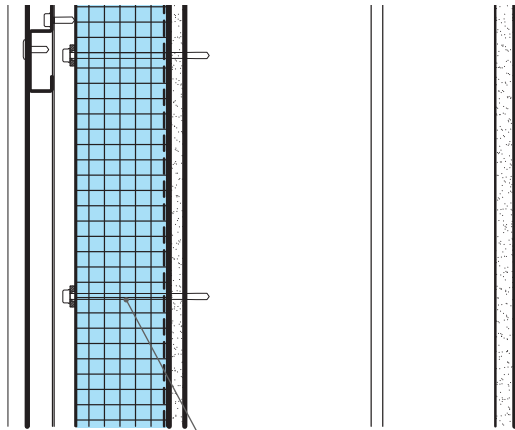

vertical Z-girt changed to thermally broken support system with only bolts penetrating insulation

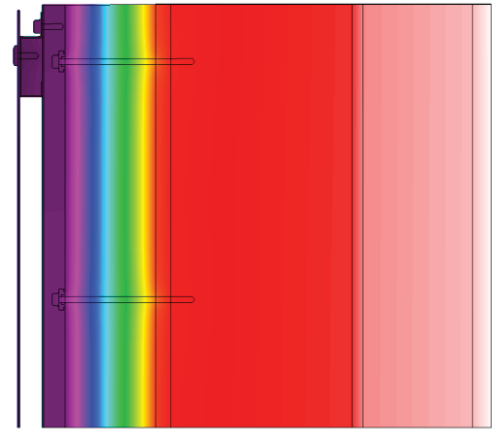

R-16.2
(-46.6%)

APPENDIX- 01c | RAINSCREENS: Horizontal Z-Girts with Fiberglass Clips

Project Conditions

Location: Eastern Massachusetts
 Date of Thermal Image: N/A
 Exterior Air Temperature: NA
 Interior Air Temperature: NA
 Radiant Temperature: NA
 Assumed Emissivity: NA

Summary of Thermal Performance

Calculated Baseline R-Value: 20.86 -
As-Built Condition
 Thermal Image R-Value: N/A N/A
 Simulated (THERM) R-Value: 16.79 -20 %
Thermally Improved Condition
 Simulated (THERM) R-Value: N/A N/A

As-Built Condition

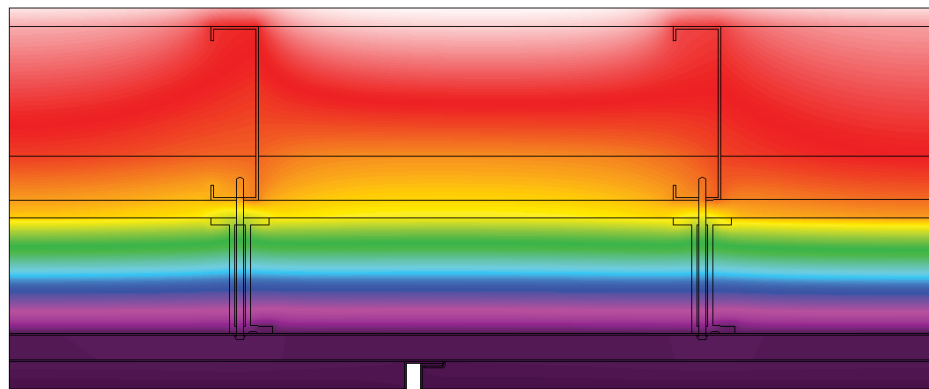
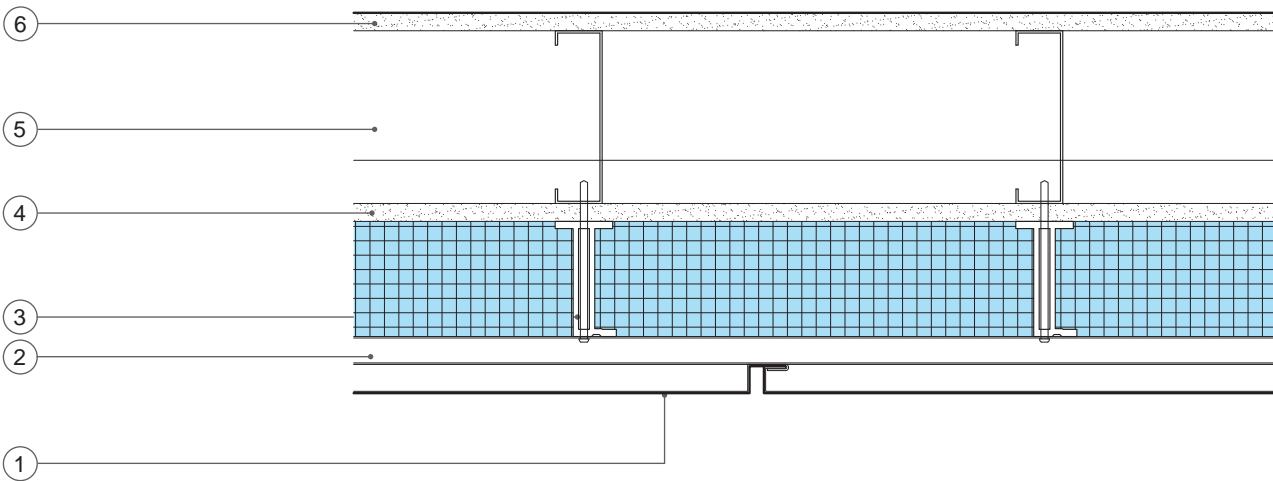

APPENDIX- 01c | RAINSCREENS: Horizontal Z-Girts with Fiberglass Clips

Calculated Baseline Clear Wall R-value									
	Material	Width in.	<i>k</i> <i>Btu-in/h-ft2·°F</i>	R-value h-ft2·°F/Btu		Material	Width in.	<i>k</i> <i>Btu-in/h-ft2·°F</i>	R-value h-ft2·°F/Btu
①	Aluminum metal panel	-	-	-	④	Sheathing	0.625	1.10	0.57
②	Horizontal rail	-	-	-	⑤	Air Cavity	6	-	1.36
-	Exterior film	-	-	0.68	⑥	Gypsum board	0.625	1.10	0.57
③	Insul w/ fiberglass clip	4	0.23	17	-	Interior Air Film	-	-	0.68
								total	20.86

Digital Image

Infrared Image

Thermally Improved Condition



fiberglass intermittent clip system is 200 times less conductive than steel

APPENDIX- 01d | RAINSCREENS: Thermally Broken Support System

Project Conditions

Location: Eastern Massachusetts
 Date of Thermal Image: N/A
 Exterior Air Temperature: N/A
 Interior Air Temperature: N/A
 Radiant Temperature: N/A
 Assumed Emissivity: N/A

Summary of Thermal Performance

Calculated Baseline R-Value: 23.86 -
As-Built Condition
 Thermal Image R-Value: N/A N/A
 Simulated (THERM) R-Value: 21.36 - 10 %
Thermally Improved Condition
 Simulated (THERM) R-Value: N/A N/A%

As-Built Condition

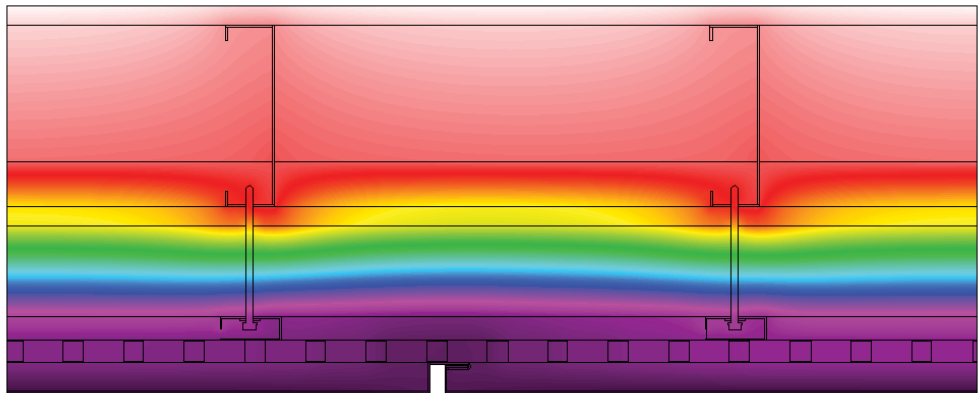
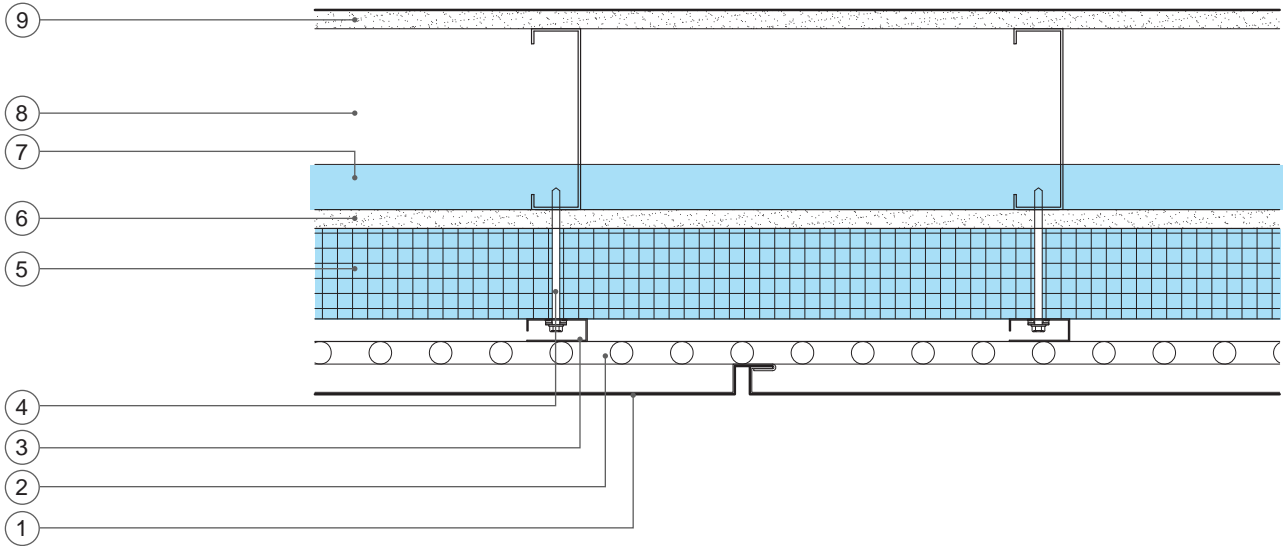

APPENDIX- 01d | RAINSCREENS: Thermally Broken Support System

Calculated Baseline Clear Wall R-value									
	Material	Width in.	k <i>Btu-in/h-ft2·°F</i>	R-value h-ft2·°F/Btu		Material	Width in.	k <i>Btu-in/h-ft2·°F</i>	R-value h-ft2·°F/Btu
					(5)	XPS Insulation	3.00	0.20	15
(-)	Exterior Air Film	-	-	0.68	(6)	Sheathing	0.625	1.10	0.57
(1)	Metal Panel	-	-	-	(7)	Polyiso Insulation	1.50	1.5	5.00
(2)	RS-Rail-Steel	-	-	-	(8)	Air Space	6	-	1.36
(3)	RS-Rail-Steel	-	-	-	(9)	Gypsum Board	0.625	1.10	0.57
(4)	Stainless Screw	-	-	-	-	Interior Air Film	-	-	0.68
							total		23.86

Digital Image

Infrared Image

Thermally Improved Condition

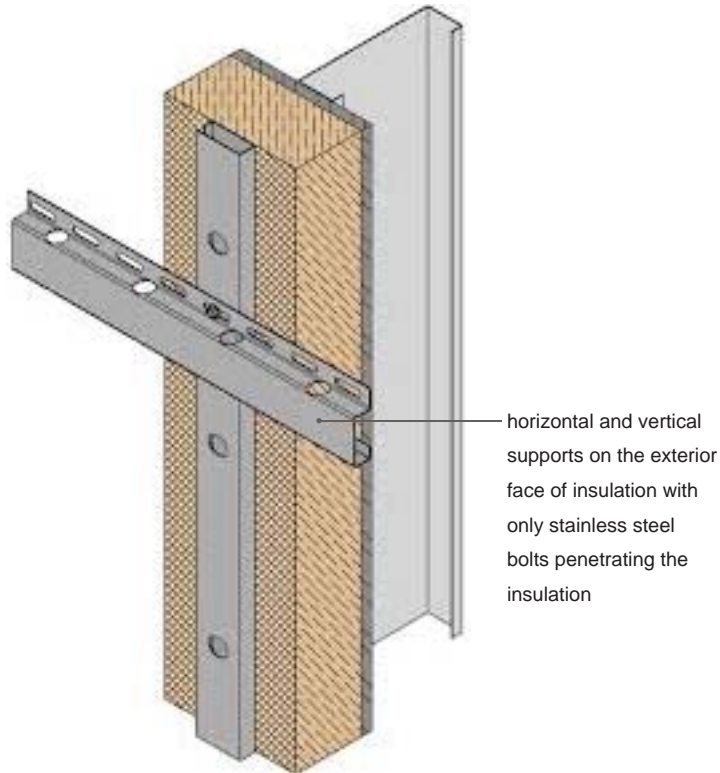

APPENDIX- 01e | RAINSCREENS: Thermally Broken Clip

Project Conditions

Location: Eastern Massachusetts
 Date of Thermal Image: N/A
 Exterior Air Temperature: N/A
 Interior Air Temperature: N/A
 Radiant Temperature: N/A
 Assumed Emissivity: N/A

Summary of Thermal Performance

Calculated Baseline R-Value: 29.86 -
As-Built Condition
 Thermal Image R-Value: N/A N/A
 Simulated (THERM) R-Value: 22.45 -25 %
Thermally Improved Condition
 Simulated (THERM) R-Value: N/A N/A

As-Built Condition

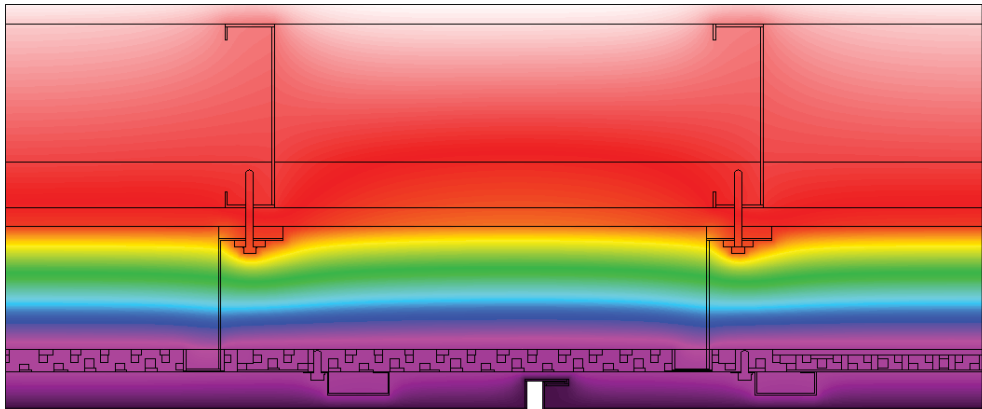
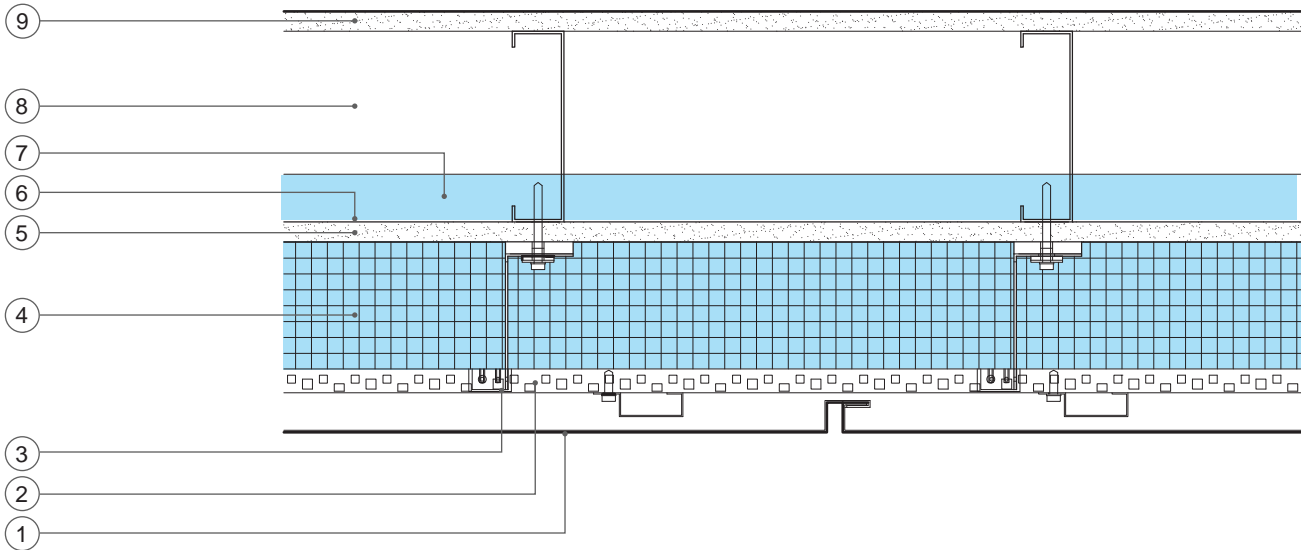

APPENDIX- 01e | RAINSCREENS: Thermally Broken Clip

Calculated Baseline Clear Wall R-value									
	Material	Width in.	k <i>Btu-in/h-ft²·°F</i>	R-value h-ft ² ·°F/Btu		Material	Width in.	k <i>Btu-in/h-ft²·°F</i>	R-value h-ft ² ·°F/Btu
					(5)	Exterior Sheathing	0.625	1.10	0.57
-	Exterior Air Film	-	-	0.68	(6)	Air and Vapor Barrier	-	-	-
(1)	Metal Panel	-	-	-	(7)	Polyurethane Foam	1.50	0.1664	9
(2)	Steel Rail	-	-	-	(8)	Air Cavity	4.5	-	1.36
(3)	Steel Clip	-	-	-	(9)	Gypsum Board	0.625	1.10	0.57
(4)	Mineral Wool	4.00	0.23	17.00	-	Interior Air Film	-	-	0.68
							total		29.35

Digital Image

Infrared Image

Thermally Improved Condition



discontinuous steel
bracket with isolator
pads on both warm and
cold side of insulation

APPENDIX- 02a | MASONRY WALLS: Masonry Brick Tie Comparison

Brick Tie Study

This study works with limited variables to see how the spacing, type and material of brick ties affects the R value of the brick venner wall. The back up assumed for this study is light gauge metal framing.

16x16 Galvanized Barrel

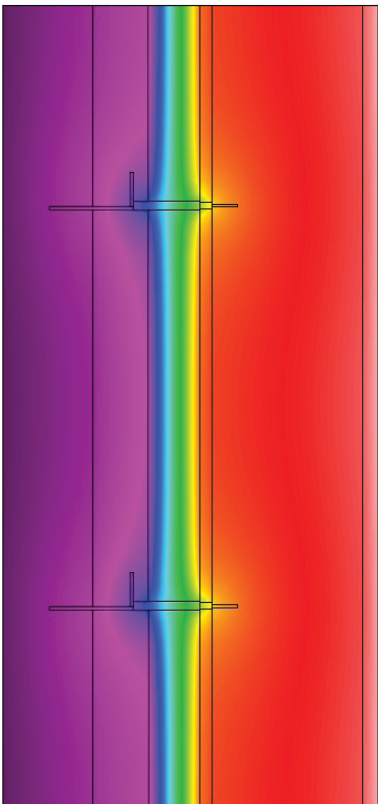

R-12.54
(-15%)

16x16 Stainless Barrel

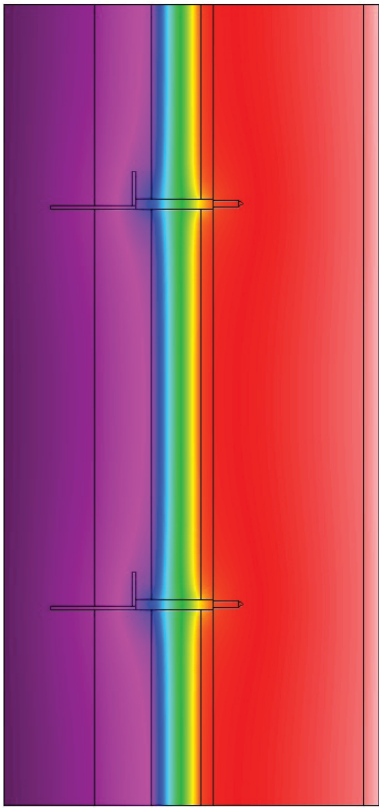

R-13.72
(-7%)

APPENDIX- 02a | MASONRY WALLS: Masonry Brick Tie Comparison

LOSS %		-1	-2	-3	-4	-5	-6	-7	-8	-9	-10	-11	-12	-13	-14	-15	
TIE SPACING	16 X 16	B						▲								●	
		S		▲						●							
	16 X 16	B					▲						●				
		S		▲					●								
	16 X 24	B					▲										
		S									●						
R 14.75 (BASE WALL NO TIES)																	

● GALVANIZED ▲ STAINLESS

16x24 Galvanized Screw

16x24 Stainless Screw

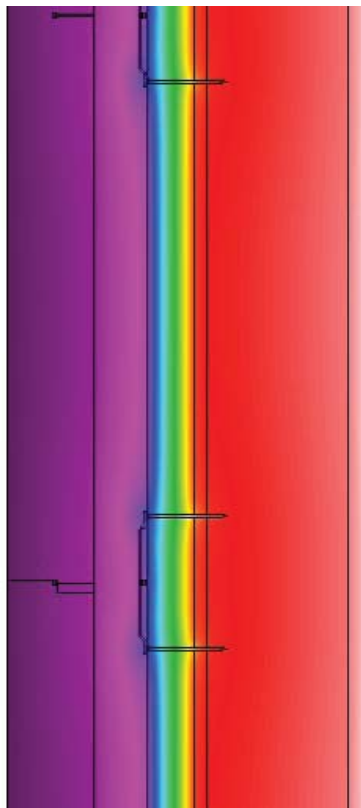

R-13.72
(-7%)

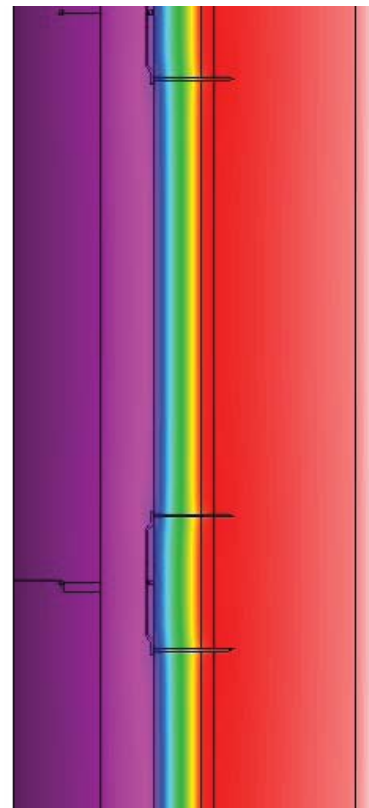

R-14.46
(-2%)

APPENDIX- 02b | MASONRY WALLS: Masonry Shelf Angle Comparison

Shelf Angle Study

This study works with limited variables to see how the material and the continuity of shelf angles affects the R value of the brick veneer wall. The back up assumed for this study is light gauge metal framing.

In addition this study looked at the traditional and improved option combined with the brick tie study.

Summary of Thermal Performance

Calculated Baseline R-Value:	18.75	-
As-Built Condition		
Thermal Image R-Value:	N/A	N/A
Simulated (THERM) R-Value:	18.40	
Thermally Improved Condition		
Simulated (THERM) R-Value:	N/A	N/A

Continuous Galvanized Shelf Angle

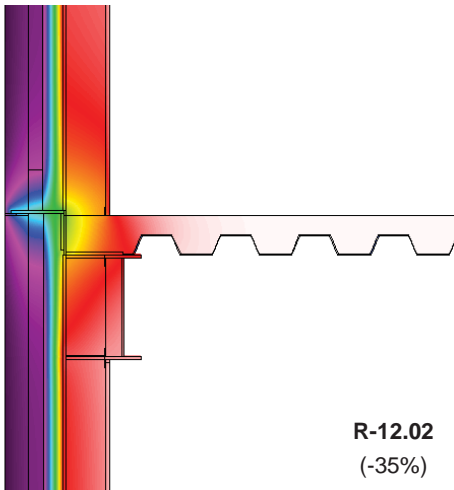

Continuous Stainless Shelf Angle

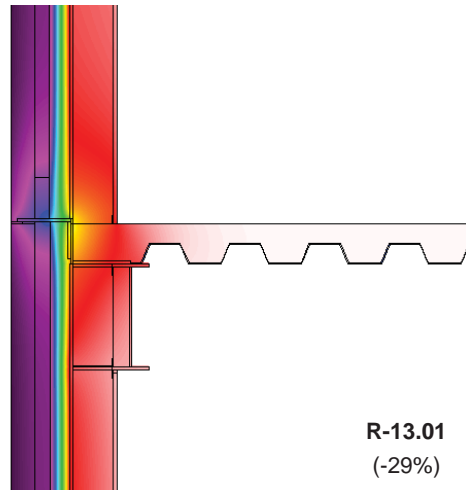

Discontinuous Galvanized Shelf Angle

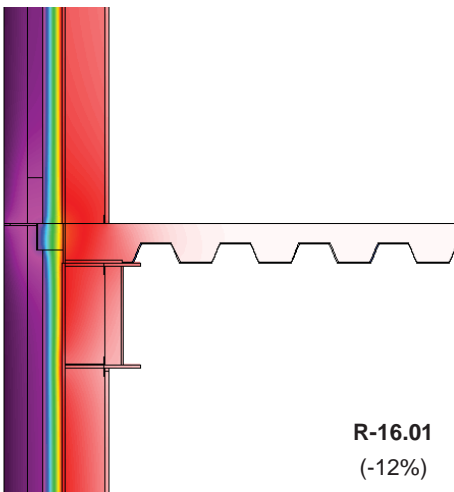

Discontinuous Stainless Shelf Angle

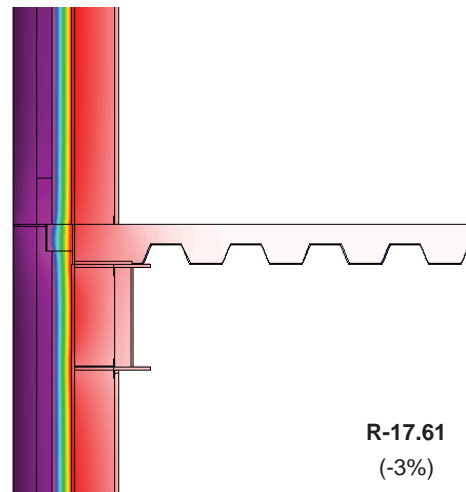

APPENDIX- 02b | MASONRY WALLS: Masonry Shelf Angle Comparison

Calculated Baseline Clear Wall R-value									
	Material	Width in.	<i>k</i> Btu·in/h·ft ² ·°F	R-value h·ft ² ·°F/Btu		Material	Width in.	<i>k</i> Btu·in/h·ft ² ·°F	R-value h·ft ² ·°F/Btu
-	Exterior Air Film	-	-	0.17	5	Air Cavity	6.00	1.10	1.36
1	Face Brick	3.625	5.50	0.66	6	Gypsum Board	0.625	1.10	0.57
2	Air Space	2.25	-	1.36	-	Interior Air Film	-	-	0.68
3	Insulation	3.00	0.23	13					
4	Exterior Sheathing	0.50	1.10	0.45					
								total	18.75

Traditional Masonry Wall with Galvanized Barrel Ties and a Continuous Galvanized Shelf Angle.

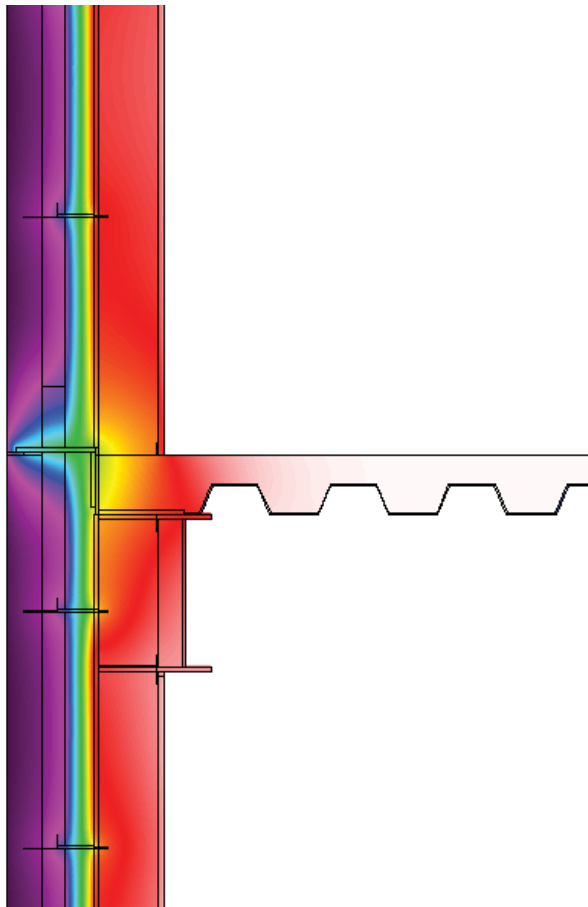

R-11.57
(-37%)

Improved Masonry Wall with Stainless Screw Ties and a Discontinuous Stainless Shelf Angle.

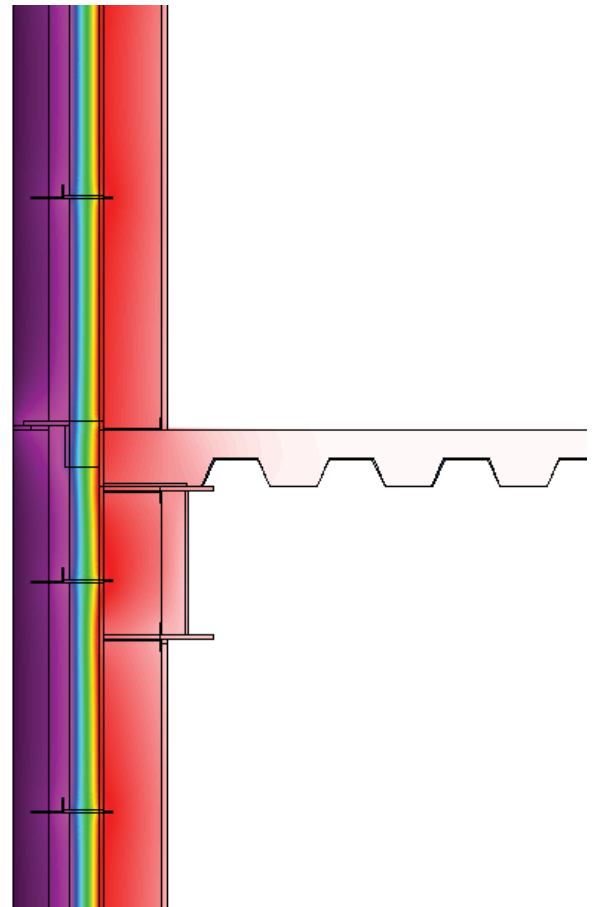

R-17.30
(-6%)

APPENDIX- 02c | MASONRY WALLS: CMU Back Up Wall Galvanized Ties

Project Conditions

Location: Western Massachusetts
 Date of Thermal Image: 2/27/2012
 Exterior Air Temperature: 46 °F
 Interior Air Temperature: 68.8 °F
 Radiant Temperature: 71.5 °F
 Assumed Emissivity: 0.9

Summary of Thermal Performance

Calculated Baseline R-Value: 15.44 -
As-Built Condition
 Thermal Image R-Value: 12.3 - 20 %
 Simulated (THERM) R-Value: 13.28 - 14 %
Thermally Improved Condition
 Simulated (THERM) R-Value: 13.68 - 11 %

As-Built Condition

Calculated Baseline Clear Wall R-value				
	Material	Width in.	k Btu-in/ h-ft2-°F	R-value h-ft2-°F/ Btu
-	Exterior Air Film	-	-	0.17
①	Face Brick	3.625	5.50	0.66
②	Air Space	2.25	-	1
③	Extruded Polystyrene	2.00	0.20	10
④	Air and Vapor Barrier	-	-	-
⑤	Concrete Block	7.625	8	1
⑥	Air Cavity	3.625	-	1.36
⑦	Gypsum Board	0.625	1.10	0.57
-	Interior Air Film	-	-	0.68
			total	15.44

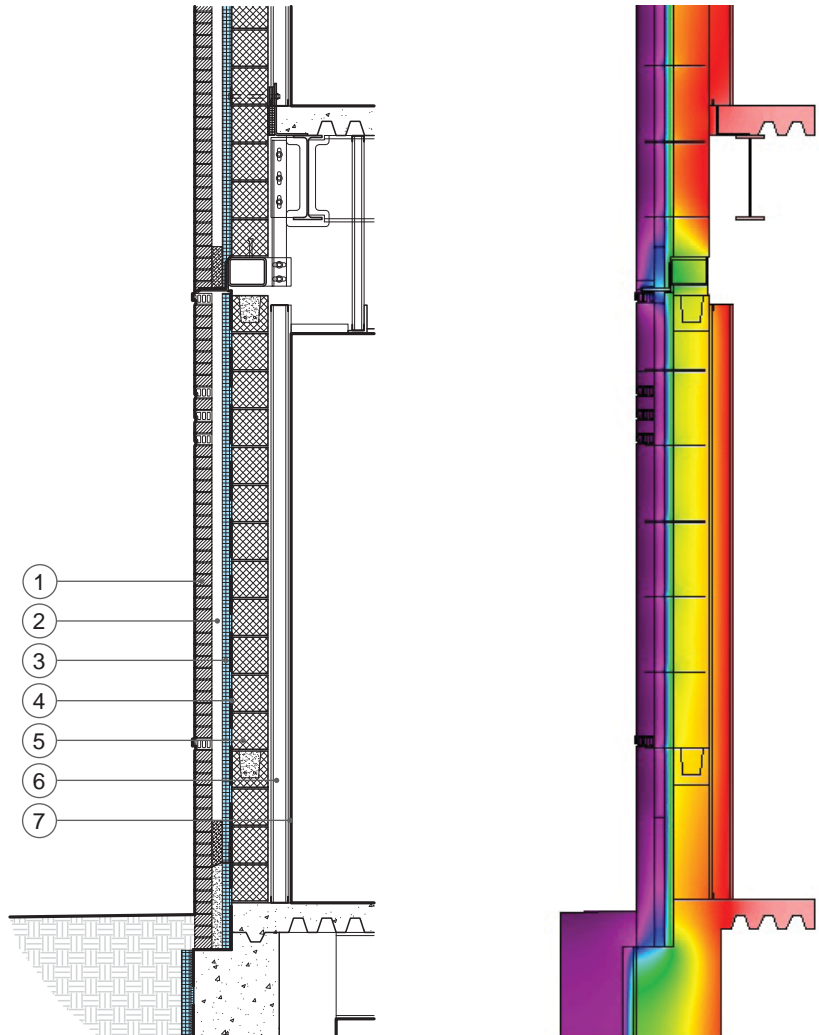

R-13.28

APPENDIX- 02c | MASONRY WALLS: CMU Back Up Wall Galvanized Ties



Digital Image

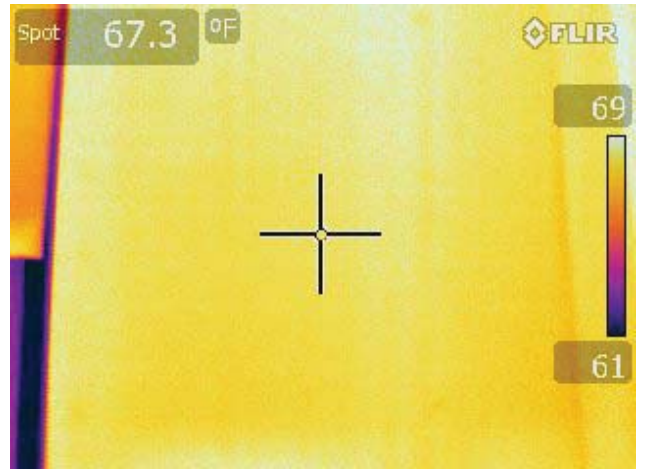

Infrared Image

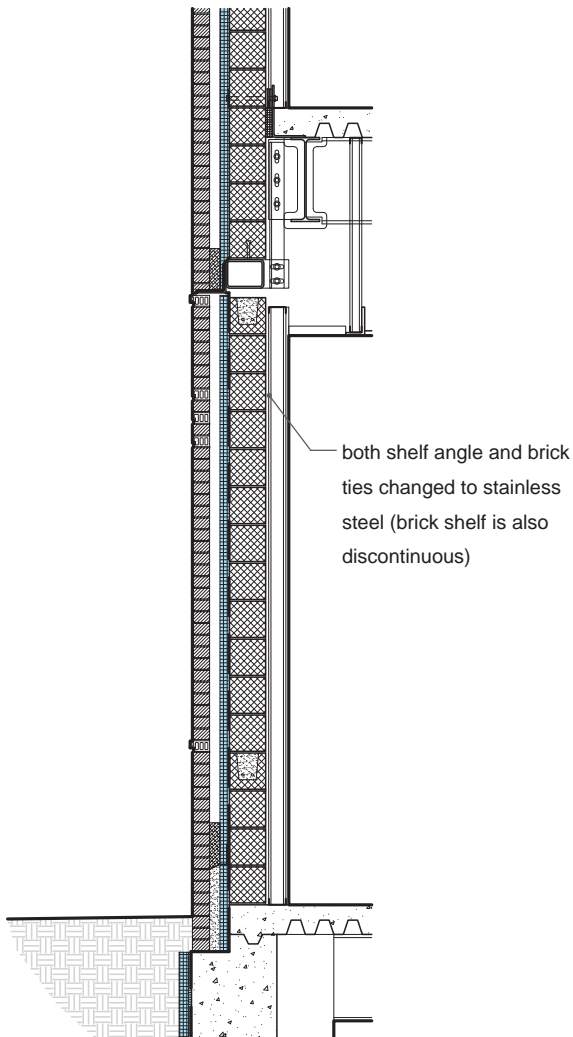

both shelf angle and brick ties changed to stainless steel (brick shelf is also discontinuous)

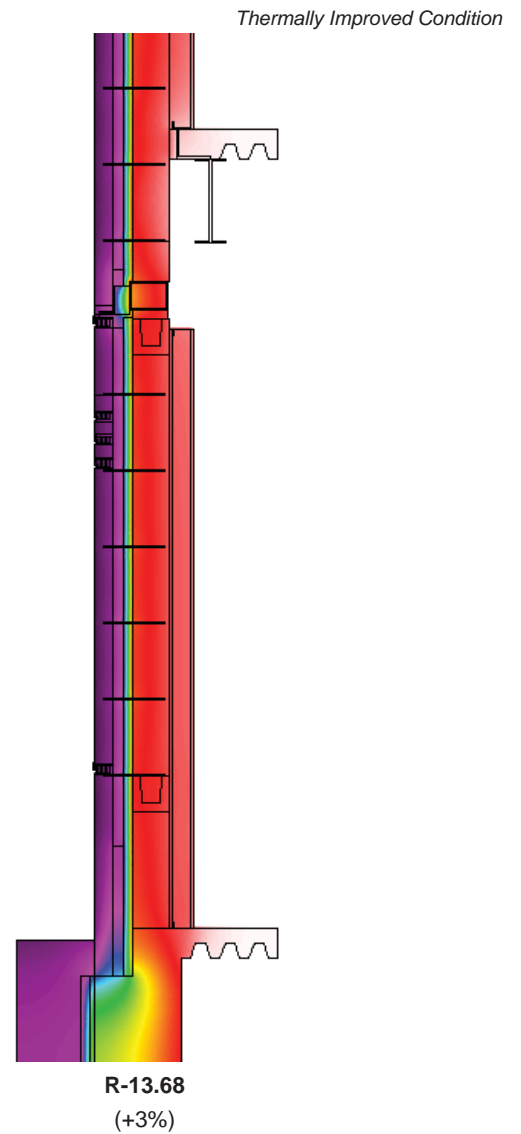

Thermally Improved Condition

R-13.68
(+3%)

APPENDIX- 02b | MASONRY WALLS: Stud Back Up Wall with Galvanized Ties

Project Conditions

Location: Western Massachusetts
 Date of Thermal Image: 2/27/2012
 Exterior Air Temperature: 46 °F
 Interior Air Temperature: 70.4 °F
 Radiant Temperature: 74.6 °F
 Assumed Emissivity: 0.9

Summary of Thermal Performance

Calculated Baseline R-Value: 15.71 -
As-Built Condition
 Thermal Image R-Value: 6.5 - 58 %
 Simulated (THERM) R-Value: 9.47 - 40 %
Thermally Improved Condition
 Simulated (THERM) R-Value: 10.53 - 33 %

As-Built Condition

Calculated Baseline Clear Wall R-value				
	Material	Width in.	k Btu-in/ h-ft2-°F	R-value h-ft2-°F/ Btu
-	Exterior Air Film	-	-	0.17
①	Face Brick	3.625	5.50	0.66
②	Air Space	2.25	-	1
③	Rigid Insulation	2.00	0.20	10
④	Air and Vapor Barrier	-	-	-
⑤	Exterior Sheathing	0.625	1.10	0.57
⑥	Air Cavity	-	-	1.36
⑦	Gypsum Board	0.625	1.10	0.57
-	Interior Air Film	-	-	0.68
			total	15.71

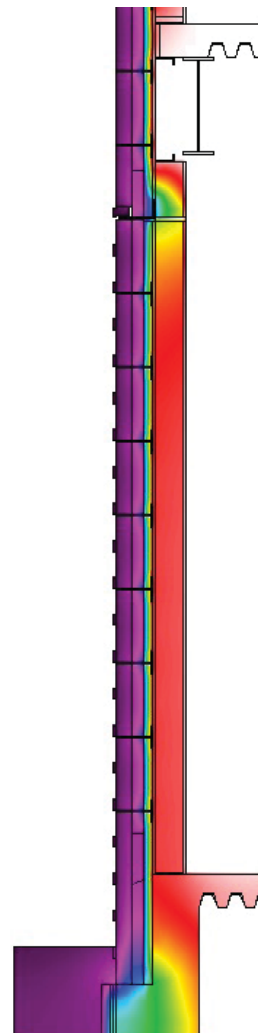
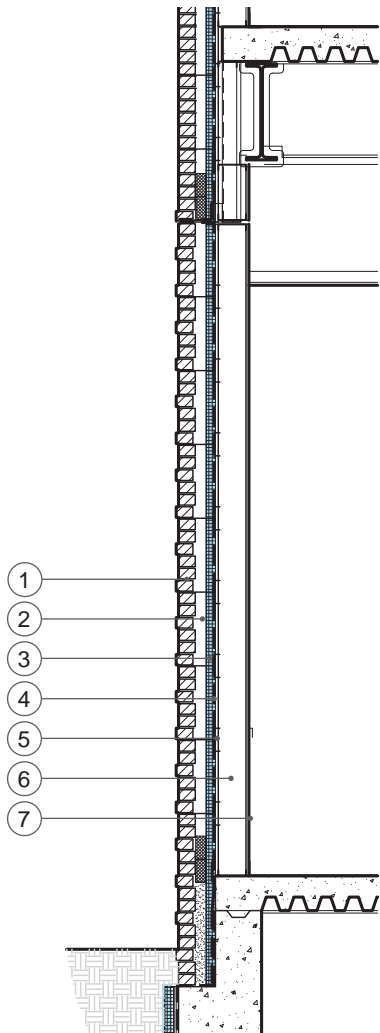

APPENDIX- 02b | MASONRY WALLS: Stud Back Up Wall with Galvanized Ties



Digital Image

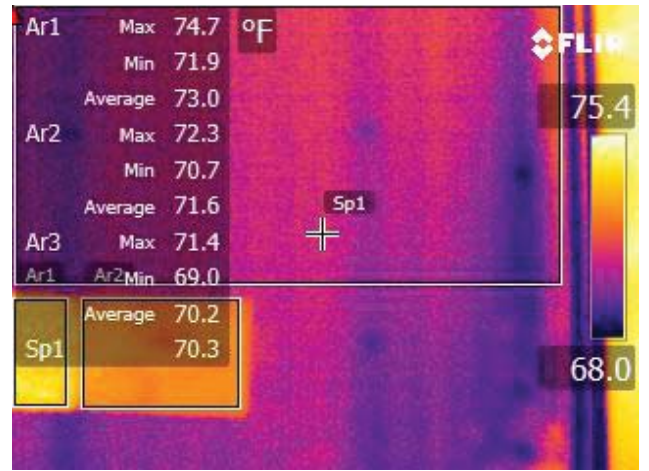

Infrared Image

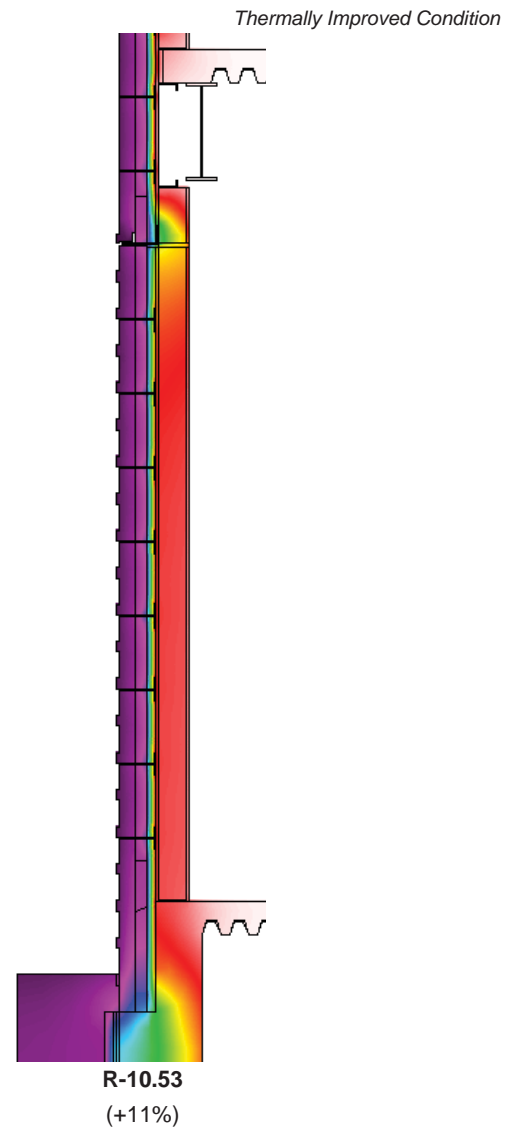
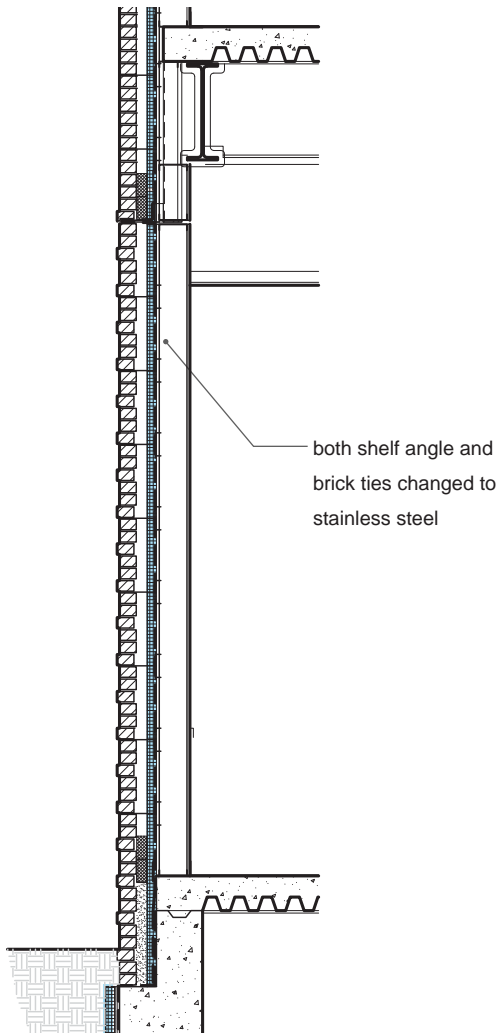

APPENDIX- 02c | MASONRY WALLS: Stud Back Up Wall with Galvanized Tie #2

Project Conditions

Location: Massachusetts
 Date of Thermal Image: 2/9/2012
 Exterior Air Temperature: 37 °F
 Interior Air Temperature: 64.1 °F
 Radiant Temperature: 65.3 °F
 Assumed Emissivity: 0.9

Summary of Thermal Performance

Calculated Baseline R-Value: 17.89 -
As-Built Condition
 Thermal Image R-Value: 8.4 - 53 %
 Simulated (THERM) R-Value: 14.43 - 19 %
Thermally Improved Condition
 Simulated (THERM) R-Value: 15.85 - 11 %

As-Built Condition

Calculated Baseline Clear Wall R-value				
	Material	Width in.	k Btu-in/ h-ft2·°F	R-value h-ft2·°F/ Btu
-	Exterior Air Film	-	-	0.17
①	Face Brick	3.625	5.50	0.66
②	Air Space	2.25	-	1
③	Mineral Wool	3.00	0.23	13
④	Air and Vapor Barrier	-	-	-
⑤	Exterior Sheathing	0.50	-	0.45
⑥	Air Cavity	6	-	1.36
⑦	Gypsum Board	0.625	1.10	0.57
-	Interior Air Film	-	-	0.68
			total	17.89

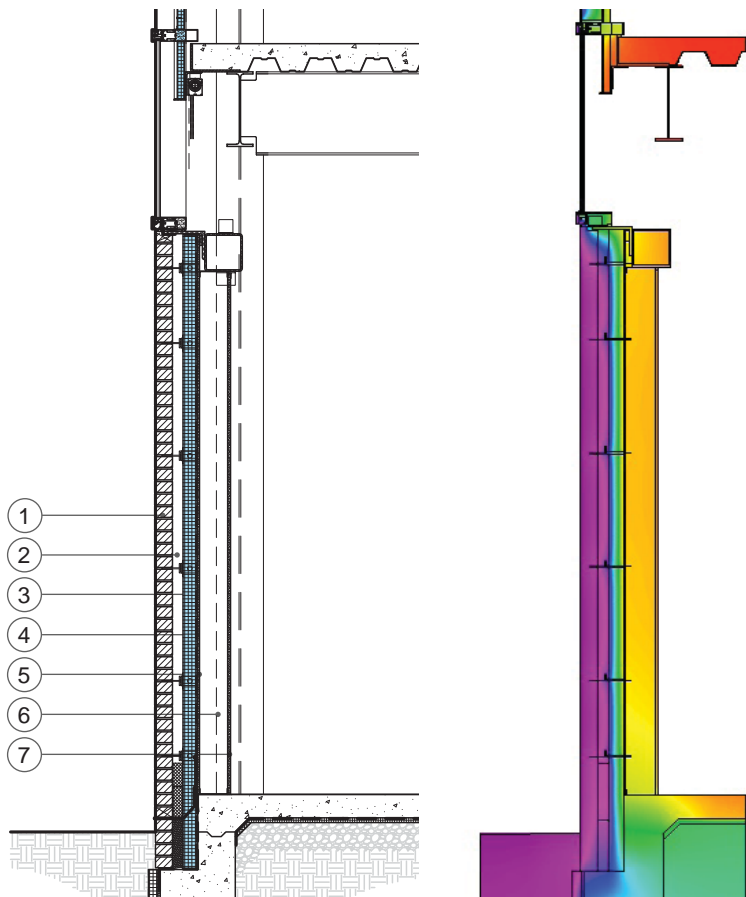

R-14.43

APPENDIX- 02c | MASONRY WALLS: Stud Back Up Wall with Galvanized Tie #2



Digital Image

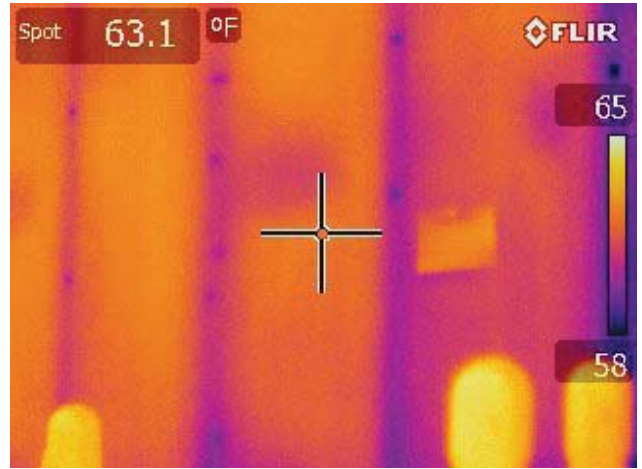

Infrared Image

Thermally Improved Condition

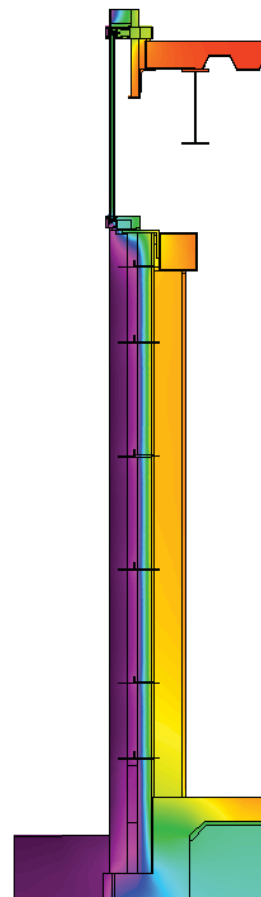
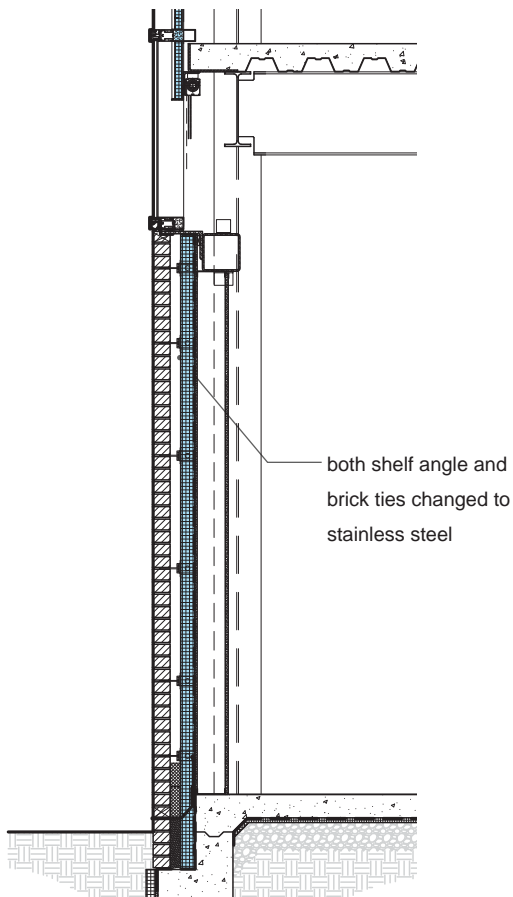

R-15.85
(+9.8%)

APPENDIX- 03a | METAL PANEL WALL SYSTEMS: Metal Panels with Insulated Joints

Project Conditions

Location: Eastern New York
 Date of Thermal Image: 2/20/2012
 Exterior Air Temperature: 34.8
 Interior Air Temperature: 68.2
 Radiant Temperature: 68.3
 Assumed Emissivity: 0.9

Summary of Thermal Performance

Calculated Baseline R-Value: 19.34 -
As-Built Condition
 Thermal Image R-Value: 18.67 - 3 %
 Simulated (THERM) R-Value: 17.55 - 9 %
Thermally Improved Condition
 Simulated (THERM) R-Value: N/A -

As-Built Condition

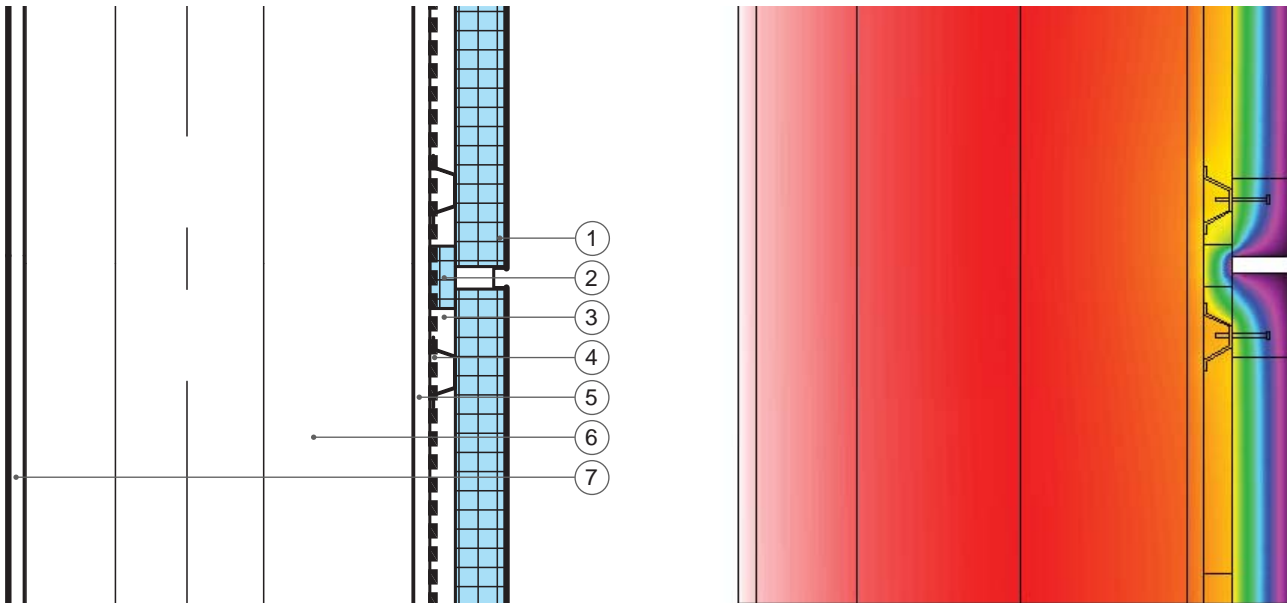

Calculated Baseline Clear Wall R-value									
	Material	Width in.	<i>k</i> Btu-in/h-ft2-°F	R-value h-ft2-°F/Btu		Material	Width in.	<i>k</i> Btu-in/h-ft2-°F	R-value h-ft2-°F/Btu
					(4)	Air and Vapor Barrier	-	-	-
-	Exterior Air Film	-	-	0.17	(5)	Exterior Sheathing	0.625	1.10	0.56
(1)	Insulated Metal Panel	2	0.20	10	(6)	Air Cavity	15.24	-	1.36
(2)	Continuous Insulation at Joint	1	0.20	5	(7)	Gypsum Board	0.625	1.10	0.56
(3)	Air Space	0.625	-	1	-	Interior Air Film	-	-	0.68
								total	19.33

APPENDIX- 03a | METAL PANEL WALL SYSTEMS: Metal Panels with Insulated Joints

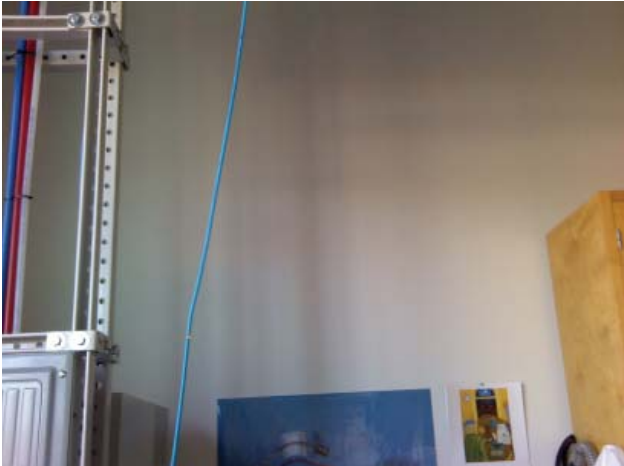

Digital Image

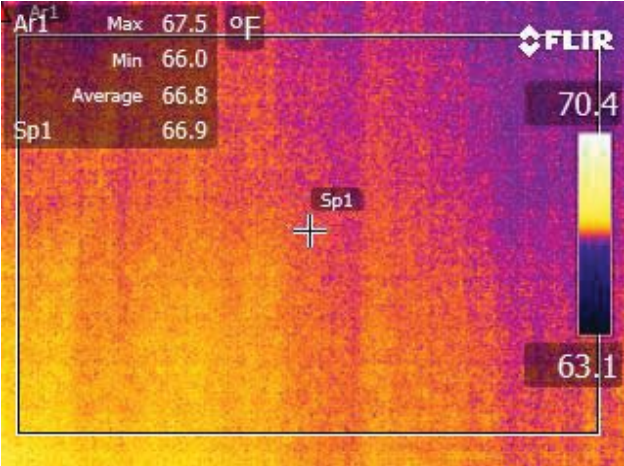

Infrared Image

APPENDIX- 03b | METAL PANEL WALL SYSTEMS: Metal Panels with Uninsulated Joints

Project Conditions

Location: Eastern Massachusetts
 Date of Thermal Image: 02/12/2012
 Exterior Air Temperature: 34.8
 Interior Air Temperature: 70.3
 Radiant Temperature: 69.7
 Assumed Emissivity: 0.9

Summary of Thermal Performance

Calculated Baseline R-Value: 20.81 -
As-Built Condition
 Thermal Image R-Value: 6.80 - 67 %
 Simulated (THERM) R-Value: 4.23 - 80 %
Thermally Improved Condition
 See 3a N/A -

As-Built Condition

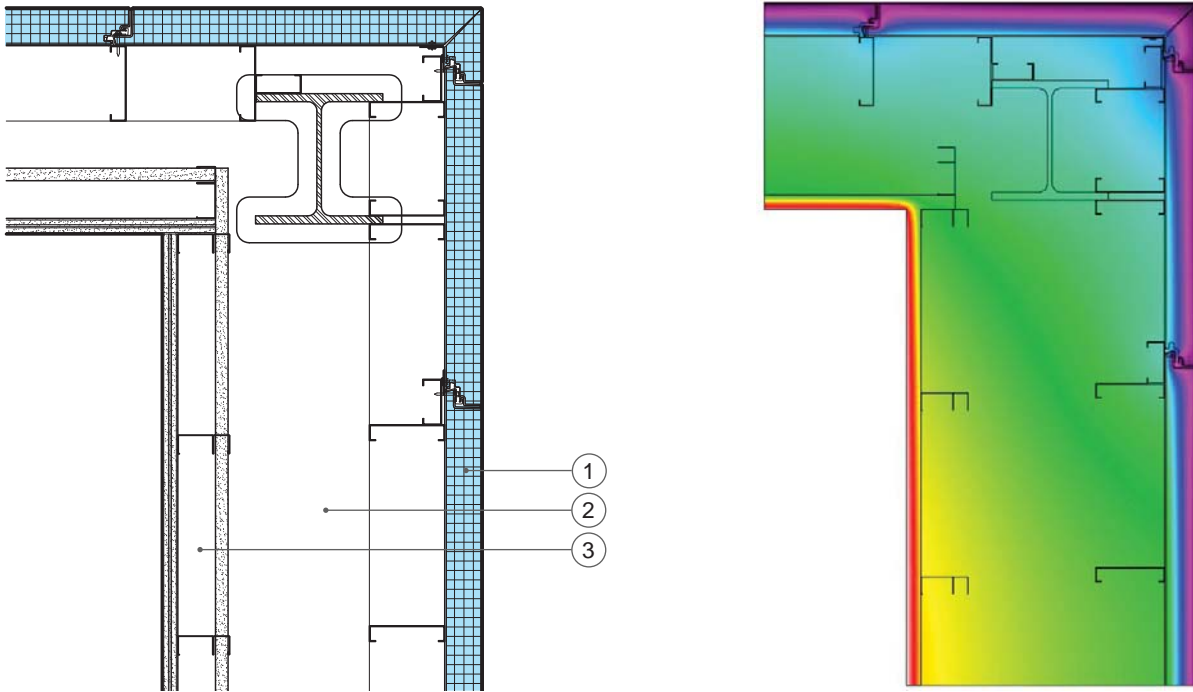

Calculated Baseline Clear Wall R-value									
	Material	Width in.	<i>k</i> Btu-in/h-ft2·°F	R-value h-ft2·°F/Btu		Material	Width in.	<i>k</i> Btu-in/h-ft2·°F	R-value h-ft2·°F/Btu
					(2)	Air Cavity	21.25	-	1.36
-	Exterior Air Film	-	-	0.17	(3)	Shaft Wall	3.75	-	3.60
(1)	Insulated Metal Panel	3	0.20	15	-	Interior Air Film	-	-	0.68
								total	20.81

APPENDIX- 03b | METAL PANEL WALL SYSTEMS: Metal Panels with Uninsulated Joints



Digital Image

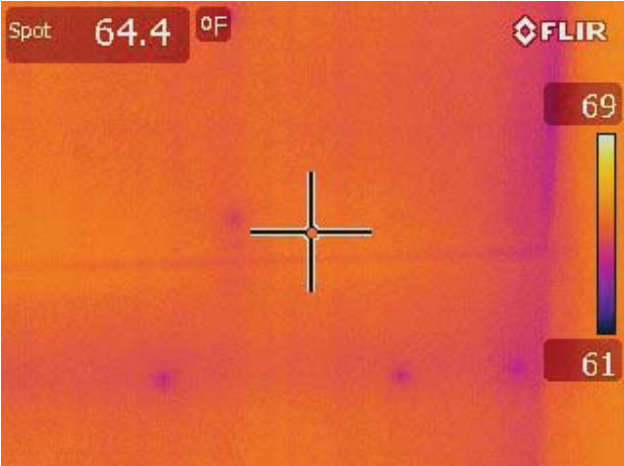

Infrared Image

APPENDIX- 03c | METAL PANEL WALL SYSTEMS: Metal Panels with Continuous Metal Clips

Project Conditions

Location: Eastern Massachusetts
 Date of Thermal Image: 02/09/2012
 Exterior Air Temperature: 36.3
 Interior Air Temperature: 63.4
 Radiant Temperature: 64.2
 Assumed Emissivity: 0.9

Summary of Thermal Performance

Calculated Baseline R-Value: 19.77 -
As-Built Condition
 Thermal Image R-Value: 5.95 - 70 %
 Simulated (THERM) R-Value: 9.70 - 51 %
Thermally Improved Condition
 See 3a N/A -

As-Built Condition

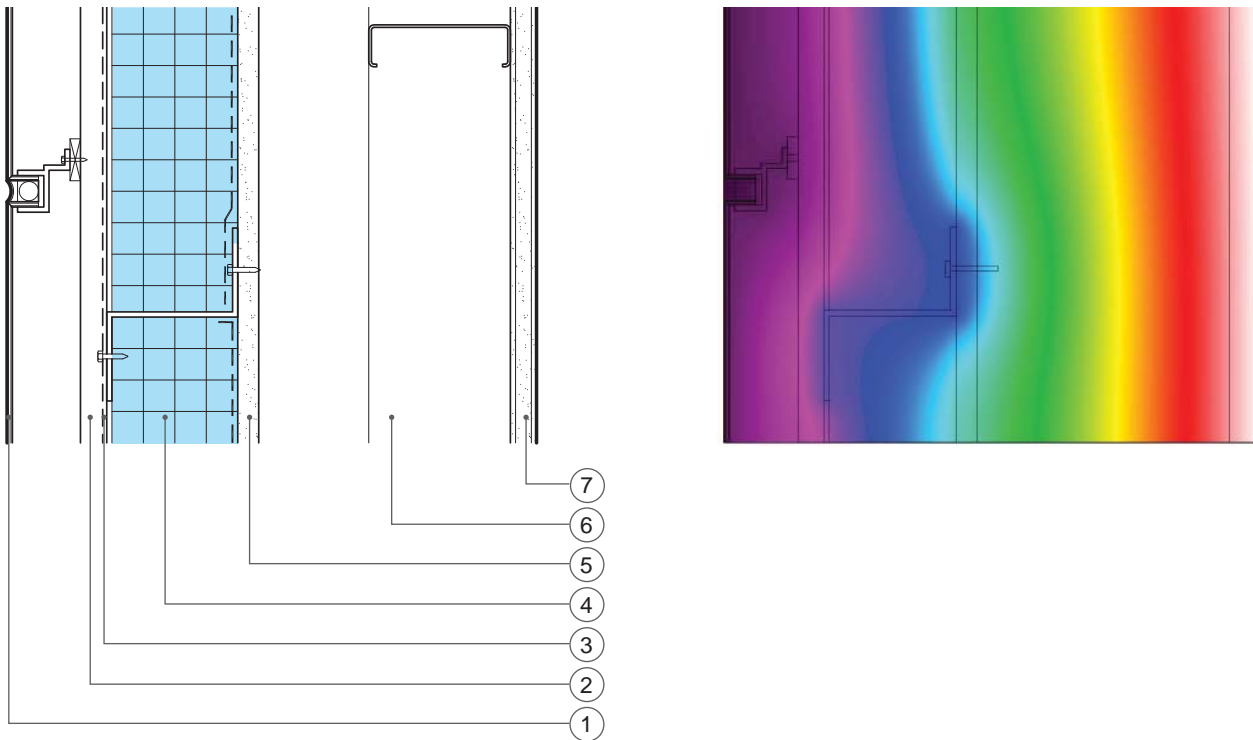

Calculated Baseline Clear Wall R-value									
	Material	Width in.	k Btu-in/h-ft ² ·°F	R-value h-ft ² ·°F/Btu		Material	Width in.	k Btu-in/h-ft ² ·°F	R-value h-ft ² ·°F/Btu
					(4)	Air and Vapor Barrier	-	-	-
-	Exterior Air Film	-	-	0.17	(5)	Exterior Sheathing	0.625	1.10	0.57
(1)	Metal Panel	-	-	0.06	(6)	Air Cavity	4	-	1.36
(2)	Air Cavity	-	-	1.36	(7)	Gypsum Board	0.625	1.10	0.57
(3)	Rigid Insulation	3.00	0.20	15	-	Interior Air Film	-	-	0.68
								total	19.77

APPENDIX- 03c | METAL PANEL WALL SYSTEMS: Metal Panels with Continuous Metal Clips



Digital Image

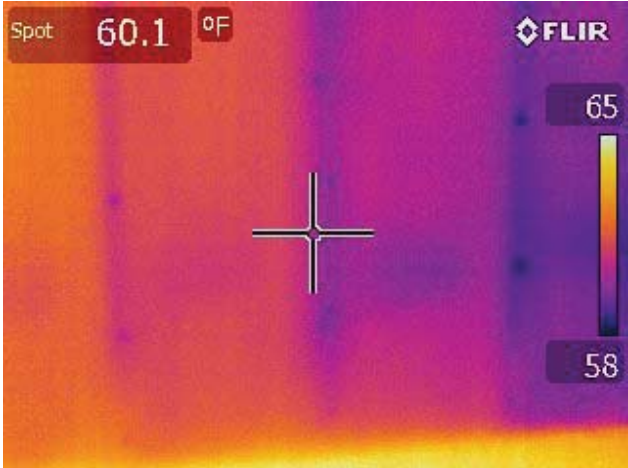

Infrared Image

Thermally Improved Condition

See 3a

APPENDIX- 04a | CURTAIN WALLS: Insulation Between Mullions (Typical)

Project Conditions

Location: Eastern Massachusetts
 Date of Thermal Image: 03/26/2013
 Exterior Air Temperature: 38.8 °F
 Interior Air Temperature: 71.1 °F
 Radiant Temperature: 72.6 °F
 Assumed Emissivity: 0.9

Summary of Thermal Performance

Calculated Baseline R-Value: 20.42 -
As-Built Condition
 Thermal Image R-Value: 5.75 - 72 %
 Simulated (THERM) R-Value: 6.17 - 70 %
Thermally Improved Condition
 Simulated (THERM) R-Value: NA

As-Built Condition

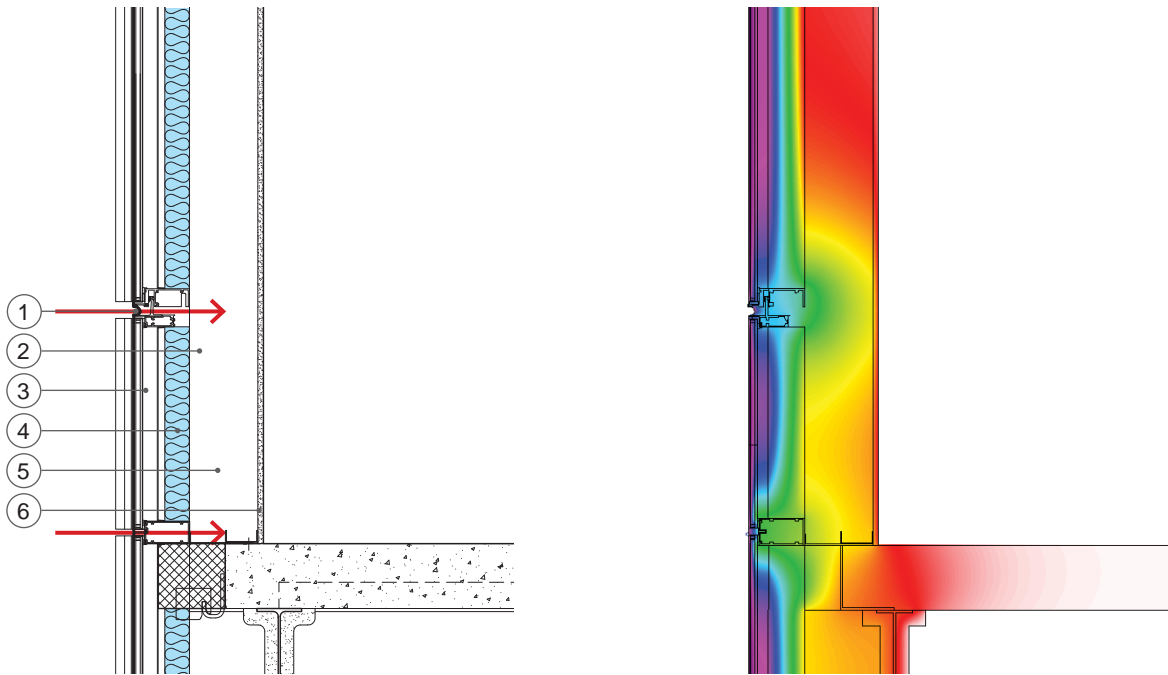

Calculated Baseline Clear Wall R-value									
	Material	Width in.	<i>k</i> Btu-in/h-ft ² ·°F	R-value h-ft ² ·°F/Btu		Material	Width in.	<i>k</i> Btu-in/h-ft ² ·°F	R-value h-ft ² ·°F/Btu
-	Exterior Air Film	-	-	0.17	(4)	Curtian Wall Insulation	4.00	0.29	13.74
(1)	Curtian Wall IGU	1.00	-	2.65	(5)	Air Cavity	7.625	-	1.36
(2)	Dead Load Anchor	-	-	-	(6)	Gypsum Board	0.625	1.10	0.57
(3)	Air Cavity	1.25	-	1.23	-	Interior Air Film	-	-	0.68
								total	20.40

APPENDIX- 04a | CURTAIN WALLS: Insulation Between Mullions (Typical)



Digital Image



Infrared Image

APPENDIX- 04b | CURTAIN WALLS: Insulation within Mullion

Project Conditions

Location: Eastern Massachusetts
 Date of Thermal Image: 02/09/2012
 Exterior Air Temperature: 38.8 °F
 Interior Air Temperature: 68.6 °F
 Radiant Temperature: 69.3 °F
 Assumed Emissivity: 0.5

Summary of Thermal Performance

Calculated Baseline R-Value: 14.16 -
As-Built Condition
 Thermal Image R-Value: 6.18 - 56 %
 Simulated (THERM) R-Value: 4.92 - 62 %
Thermally Improved Condition
 Simulated (THERM) R-Value: NA

As-Built Condition

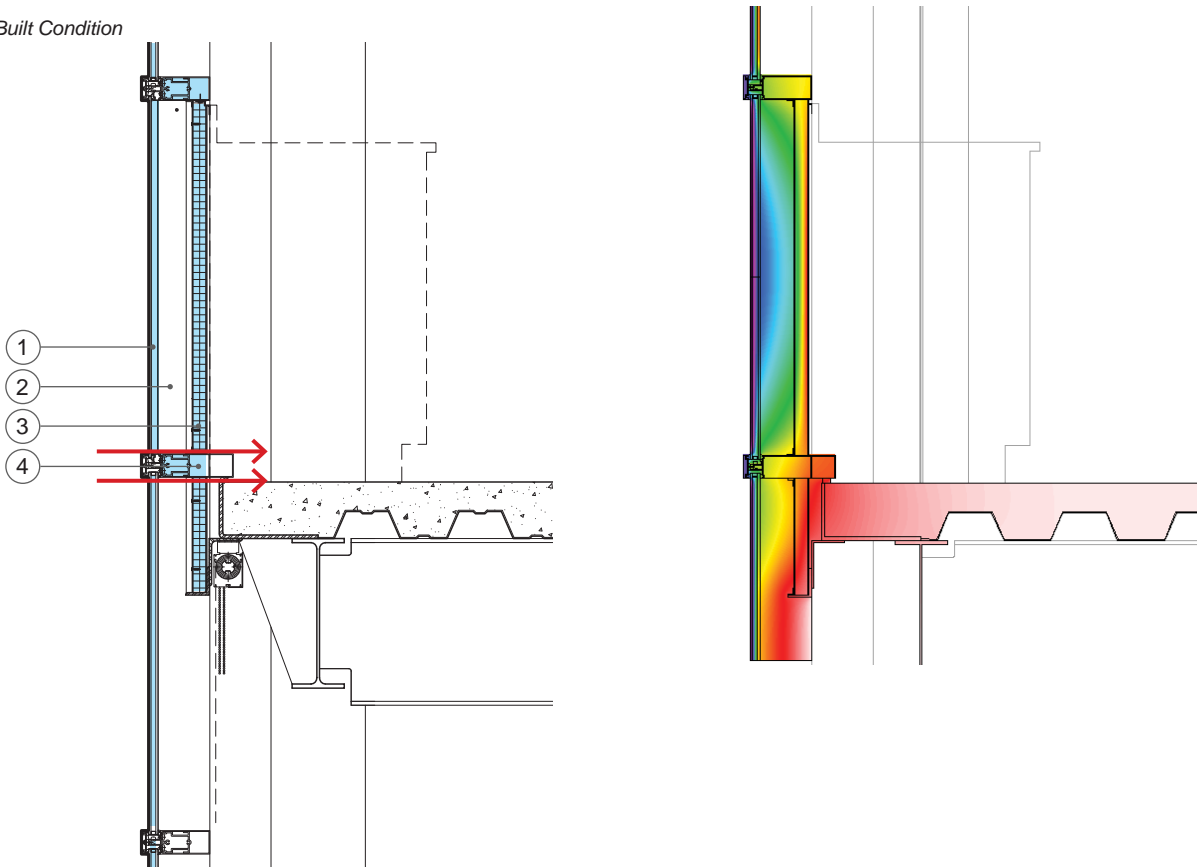

Calculated Baseline Clear Wall R-value										
	Material	Width in.	<i>k</i> Btu-in/h-ft ² ·°F	R-value h-ft ² ·°F/Btu		Material	Width in.	<i>k</i> Btu-in/h-ft ² ·°F	R-value h-ft ² ·°F/Btu	
-	Exterior Air Film	-	-	0.17	(3)	Insulated Metal Panel	1.50	0.16	9.44	
(1)	Curtain Wall IGU	1.00	-	2.73	(4)	Mullion w/ Spray Foam	5.00	0.15	-	
(2)	Air Space	3.60	-	1.14	-	Interior Air Film	-	-	0.68	
									total	14.16

APPENDIX- 04b | CURTAIN WALLS: Insulation within Mullion



Digital Image

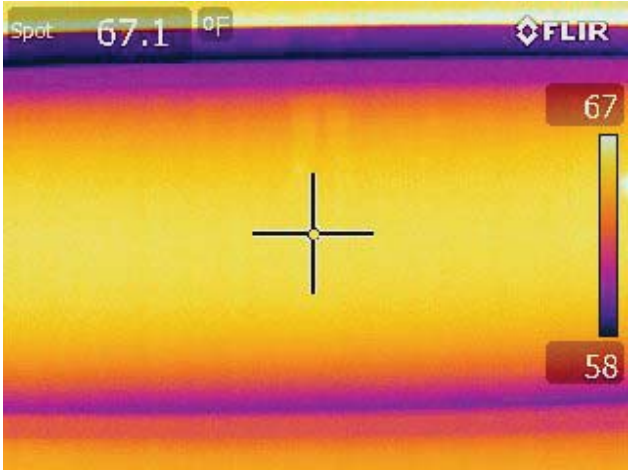

Infrared Image

Thermally Improved Condition

APPENDIX- 04c | CURTAIN WALL: Wrapped Mullion

Project Conditions

Location: Central Pennsylvania
 Date of Thermal Image: 02/13/2013
 Exterior Air Temperature: NA
 Interior Air Temperature: NA
 Radiant Temperature: NA
 Assumed Emissivity: 0.9

Summary of Thermal Performance

Calculated Baseline R-Value: 13.12 -
As-Built Condition
 Thermal Image R-Value: NA
 Simulated (THERM) R-Value: 5.11 - 61 %
Thermally Improved Condition
 Simulated (THERM) R-Value: 10.86 - 17 %

As-Built Condition

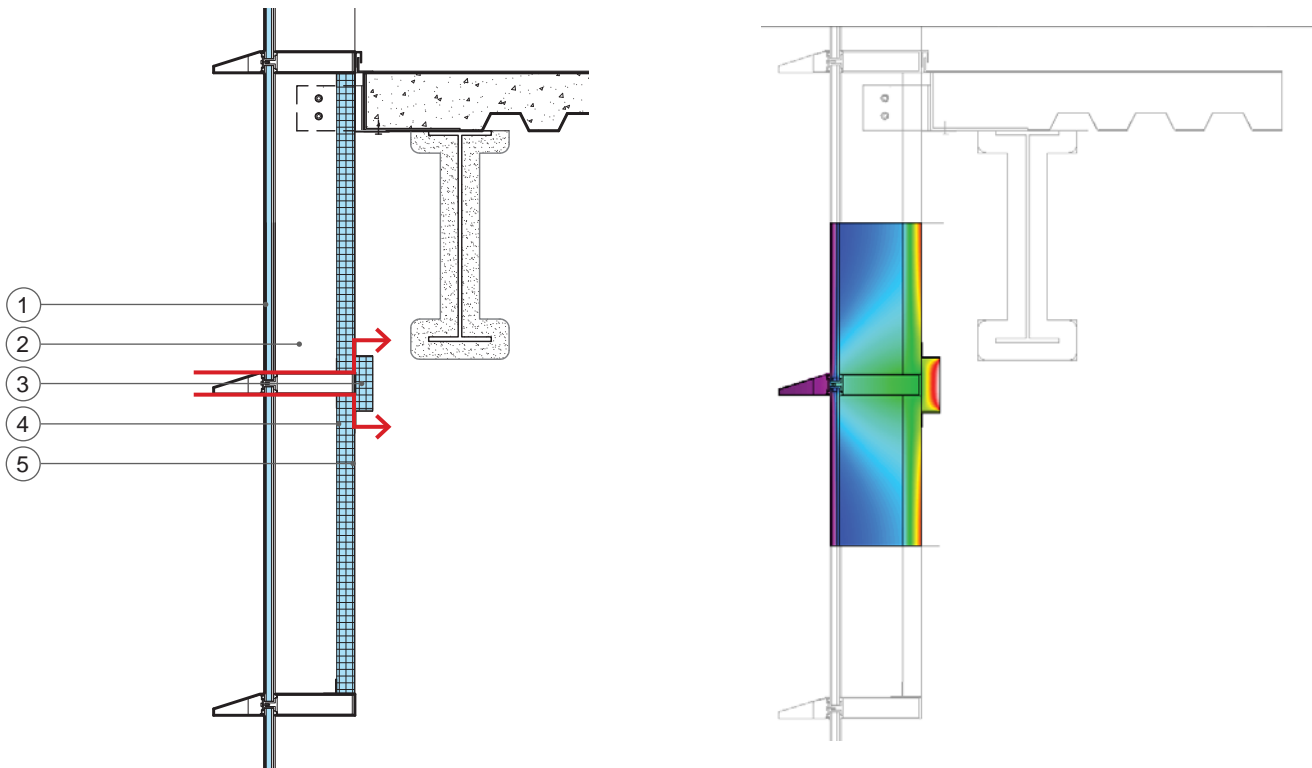

Calculated Baseline Clear Wall R-value									
	Material	Width in.	k Btu-in/h-ft ² ·°F	R-value h-ft ² ·°F/Btu		Material	Width in.	k Btu-in/h-ft ² ·°F	R-value h-ft ² ·°F/Btu
					③	Mullion w/ Mineral Wool	2.00	0.23	-
-	Exterior Air Film	-	-	0.17	④	Mineral Wool	2.00	0.23	8.69
①	Curtian Wall IGU	1.00	-	2.22	⑤	Aluminum Backpan	0.04	1643.23	0.00
②	Air Cavity	7.00	-	1.36	-	Interior Air Film	-	-	0.68
								total	13.12

APPENDIX- 04c | CURTAIN WALL: Wrapped Mullion

Digital Image

Infrared Image

Thermally Improved Condition

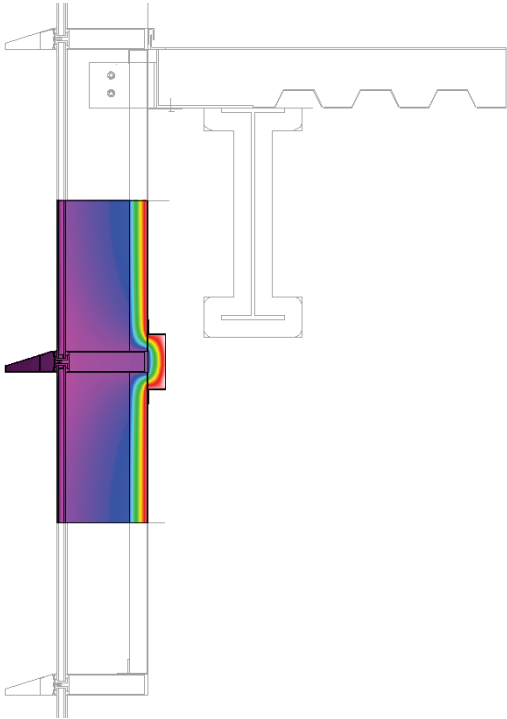
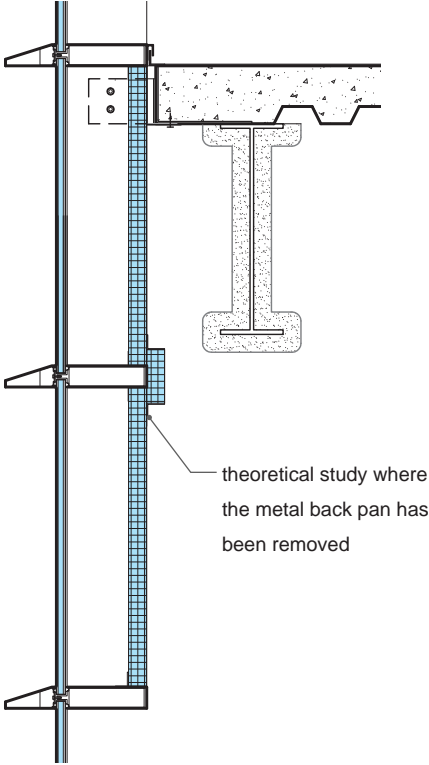

R-10.86
(+113%)

APPENDIX- 04d | CURTAIN WALL: Insulation Glazed In

Project Conditions

Location: Eastern Massachusetts
 Date of Thermal Image: 01/18/2013
 Exterior Air Temperature: NA
 Interior Air Temperature: NA
 Radiant Temperature: NA
 Assumed Emissivity: 0.9

Summary of Thermal Performance

Calculated Baseline R-Value: 11.81 -
As-Built Condition
 Thermal Image R-Value: NA
 Simulated (THERM) R-Value: 8.09 - 31 %
Thermally Improved Condition
 Simulated (THERM) R-Value: NA

As-Built Condition

Calculated Baseline Clear Wall R-value				
	Material	Width in.	k Btu-in/ h-ft2·°F	R-value h-ft2·°F/ Btu
-	Exterior Air Film	-	-	0.17
①	Curtain Wall IGU	1.00	-	2.22
②	Air Gap	0.5	-	1.15
③	Glass Wool Insulation	2.00	0.26	7.59
④	Aluminum Back Pan	0.09	1109	0.00
-	Interior Air Film	-	-	0.68
			total	11.81

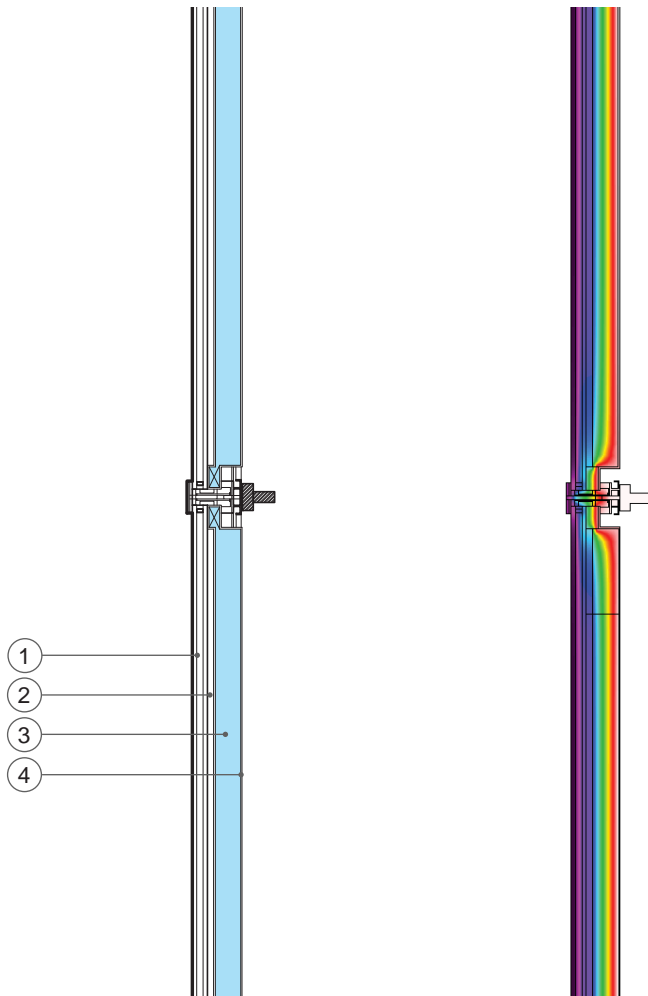



APPENDIX- 04e | CURTAIN WALL: Improved Option

Project Conditions

Location: N/A
 Date of Thermal Image: N/A
 Exterior Air Temperature: 25.3 °F
 Interior Air Temperature: 71.6 °F
 Radiant Temperature: N/A °F
 Assumed Emissivity: 0.9

Summary of Thermal Performance

Calculated Baseline R-Value: 21.21 -
As-Built Condition
 Thermal Image R-Value: N/A N/A
 Simulated (THERM) R-Value: 15.14 - 29 %
Thermally Improved Condition
 Simulated (THERM) R-Value: N/A N/A

As-Built Condition

Calculated Baseline Clear Wall R-value				
	Material	Width in.	k Btu-in/ h-ft2-°F	R-value h-ft2-°F/ Btu
-	Exterior Air Film	-	-	0.17
①	Curtain Wall	-	-	-
②	Insulation	5	0.2635	19
③	Air Cavity	4	-	1.36
④	Spandrel	-	-	-
-	Interior Air Film	-	-	0.68
			total	21.21

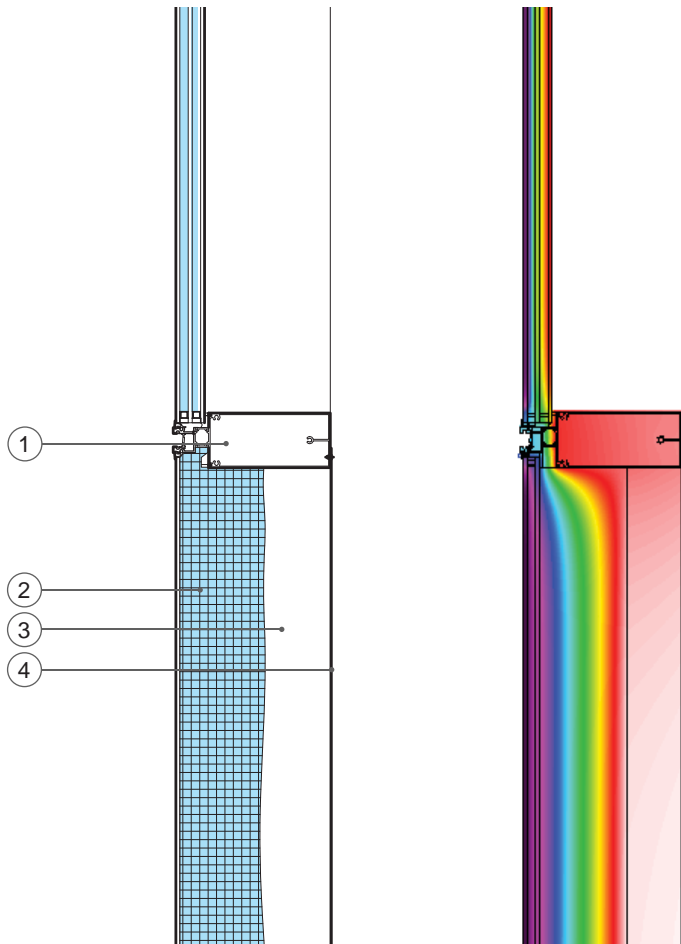

Thermally Improved Condition

APPENDIX- 05a | INSULATING EXISTING BUILDINGS: Studs Directly Attached to Existing Wall

Project Conditions

Location: Eastern Massachusetts
 Date of Thermal Image: 03/01/2012
 Exterior Air Temperature: 40 °F
 Interior Air Temperature: 72.6 °F
 Radiant Temperature: 72.1 °F
 Assumed Emissivity: 0.9

Summary of Thermal Performance

Calculated Baseline R-Value: 19.63 -

As-Built Condition

Thermal Image R-Value: 4.15 -78.9 %
 Simulated (THERM) R-Value: 8.05 -58.9 %

Thermally Improved Condition

See 05b

As-Built Condition

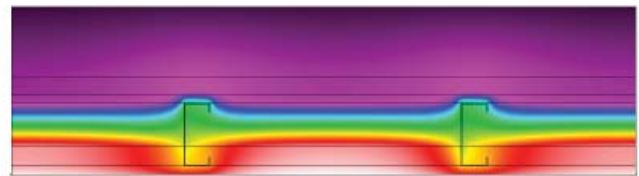
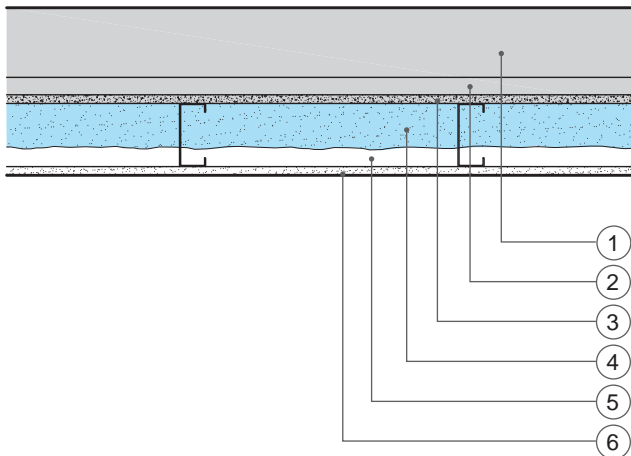

Calculated Baseline Clear Wall R-value									
	Material	Width in.	<i>k</i> Btu-in/h-ft ² ·°F	R-value h-ft ² ·°F/Btu		Material	Width in.	<i>k</i> Btu-in/h-ft ² ·°F	R-value h-ft ² ·°F/Btu
-	Exterior Air Film	-	-	0.17	④	Sprayfoam Insulation	2.5	0.166	15.06
①	Existing Brick	3.625	6.2	0.58	⑤	Air Cavity	4.5	-	1.00
②	Existing Air Cavity	1.375	-	1.00	⑥	Gypsum Board	0.625	1.1	0.57
③	Existing Sheathing	0.625	1.1	0.57	-	Interior Air Film	-	-	0.68
								total	19.63

APPENDIX- 05a | INSULATING EXISTING BUILDINGS: Studs Directly Attached to Existing Wall



Digital Image



Infrared Image

APPENDIX- 05b | INSULATING EXISTING BUILDINGS: Studs Pulled 1" Back From Existing Wall

Project Conditions

Location: Southern Connecticut
 Date of Thermal Image: 03/14/2013
 Exterior Air Temperature: 36 °F
 Interior Air Temperature: 68.4 °F
 Radiant Temperature: 67.9 °F
 Assumed Emissivity: 0.9

Summary of Thermal Performance

Calculated Baseline R-Value: 16.84 -
As-Built Condition
 Thermal Image R-Value: 12.44 - 26 %
 Simulated (THERM) R-Value: 14.11 - 16 %
Thermally Improved Condition
 See 05c

As-Built Condition

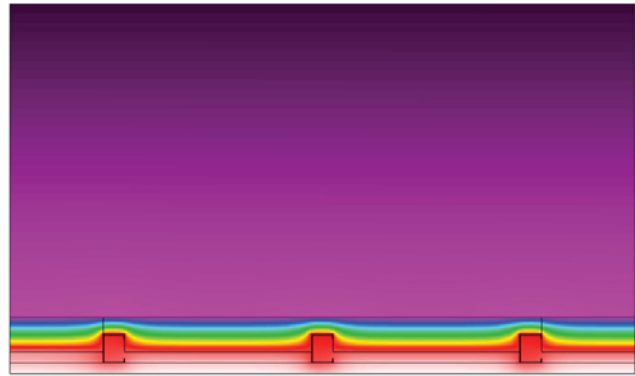
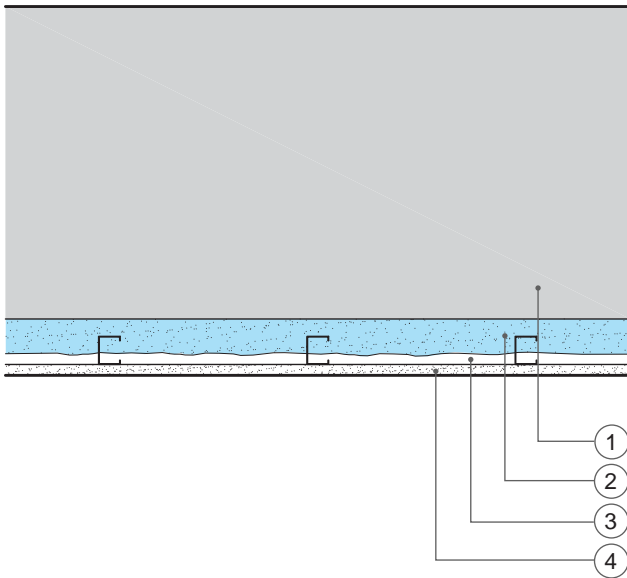

Calculated Baseline Clear Wall R-value									
	Material	Width in.	k Btu-in/h-ft2·°F	R-value h-ft2·°F/Btu		Material	Width in.	k Btu-in/h-ft2·°F	R-value h-ft2·°F/Btu
-	Exterior Air Film	-	-	0.17	③	Air Cavity	0.625	-	1.36
①	Stone	20	9.96	2.01	④	Gypsum Board	0.625	1.1	0.57
②	Sprayfoam Insulation	2	0.166	12.05	-	Interior Air Film	-	-	0.68
								total	16.84

APPENDIX- 05b | INSULATING EXISTING BUILDINGS: Studs Pulled 1" Back From Existing Wall



Digital Image

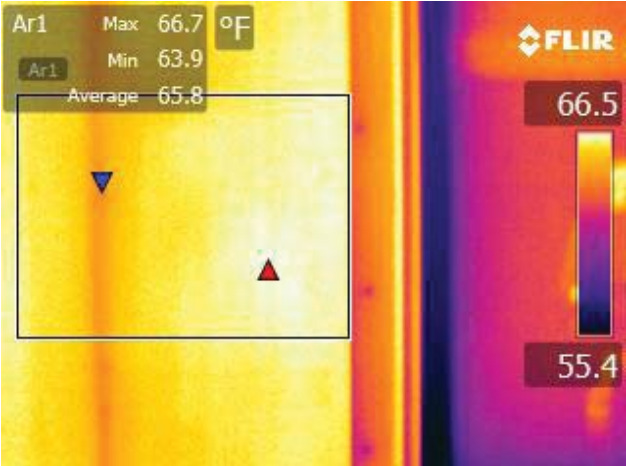

Infrared Image

APPENDIX- 05c | INSULATING EXISTING BUILDINGS: Studs Separated From Insulation

Project Conditions

Location: Eastern Massachusetts
 Date of Thermal Image: 01/23/2013
 Exterior Air Temperature: 21.1 °F
 Interior Air Temperature: 53.7 °F
 Radiant Temperature: 55.8 °F
 Assumed Emissivity: 0.9

Summary of Thermal Performance

Calculated Baseline R-Value: 29.23 -
As-Built Condition
 Thermal Image R-Value: 20.16 - 31 %
 Simulated (THERM) R-Value: 28.78 - 1.5 %
Thermally Improved Condition
 N/A -

As-Built Condition

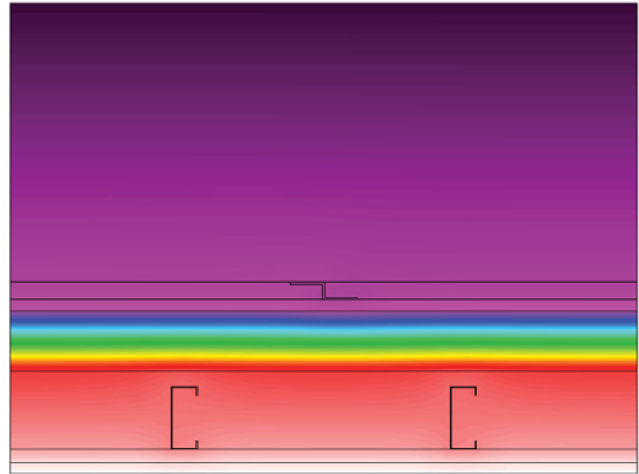
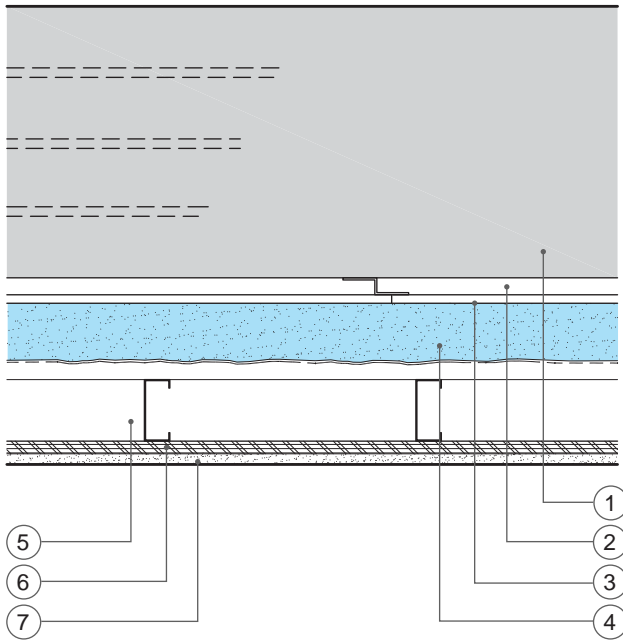

Calculated Baseline Clear Wall R-value									
	Material	Width in.	k Btu-in/h-ft2·°F	R-value h-ft2·°F/Btu		Material	Width in.	k Btu-in/h-ft2·°F	R-value h-ft2·°F/Btu
-	Exterior Air Film	-	-	0.17	(4)	Sprayfoam Insulation	3.5	0.1664	21.03
(1)	Brick	16	6.2	2.58	(5)	Air Cavity	4.5	-	1.36
(2)	Air Cavity	1	-	1.37	(6)	Plywood	0.75	0.735	1.02
(3)	Cement Board	0.5	1.1	0.45	(7)	Gypsum Board	0.625	1.1	0.57
					-	Interior Air Film	-	-	0.68
						total			29.23

APPENDIX- 05c | INSULATING EXISTING BUILDINGS: Studs Separated From Insulation



Digital Image

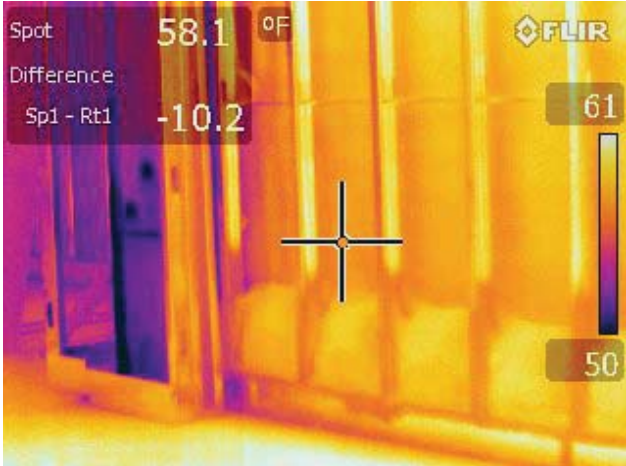

Infrared Image

APPENDIX- 06a | WINDOW TRANSITIONS: Recessed Relationship with Thermal Barrier

Project Conditions

Location: Western Massachusetts
 Date of Thermal Image: 02/27/2012
 Exterior Air Temperature: 46.0 °F
 Interior Air Temperature: 69.0 °F
 Radiant Temperature: 70.6 °F
 Assumed Emissivity: 0.9

Summary of Thermal Performance

Calculated Baseline R-Value: 15.39 -
As-Built Condition
 Thermal Image R-Value: 6.58 - 57 %
 Simulated (THERM) R-Value:
 Head 6.46 - 58 %
 Jamb 6.58 - 51 %
 Sill 4.60 - 70 %

As-Built Condition

Section Detail

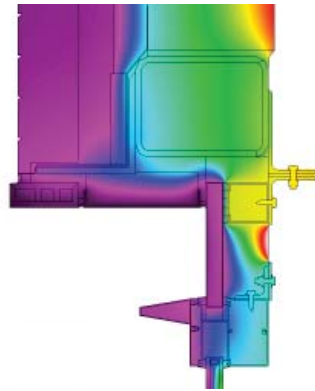
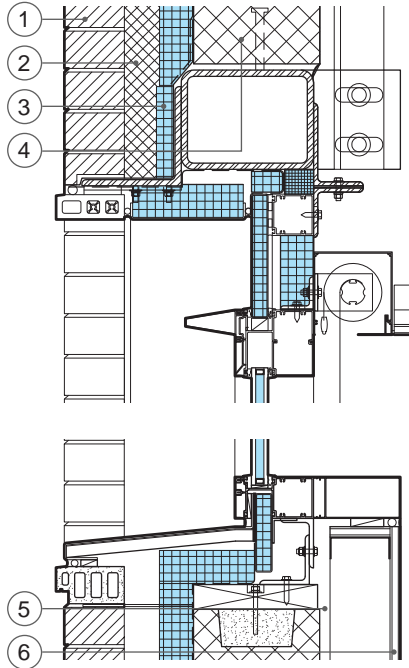

Plan Detail



Calculated Baseline Clear Wall R-value									
	Material	Width in.	<i>k</i> Btu-in/h-ft ² ·°F	R-value h-ft ² ·°F/Btu		Material	Width in.	<i>k</i> Btu-in/h-ft ² ·°F	R-value h-ft ² ·°F/Btu
-	Exterior Air Film	-	-	0.17	④	CMU	7.625	8.00	.95
①	Brick (Common)	3.625	5.5	0.66	⑤	Air Cavity	-	-	1.36
②	Air Cavity	-	-	1.00	⑥	Gypsum Board	0.625	1.10	0.57
③	Rigid Insulation	2.00	0.20	10.00	-	Interior Air Film	-	-	0.68
								total	15.39

APPENDIX- 06a | WINDOW TRANSITIONS: Recessed Relationship with Thermal Barrier



Digital Image

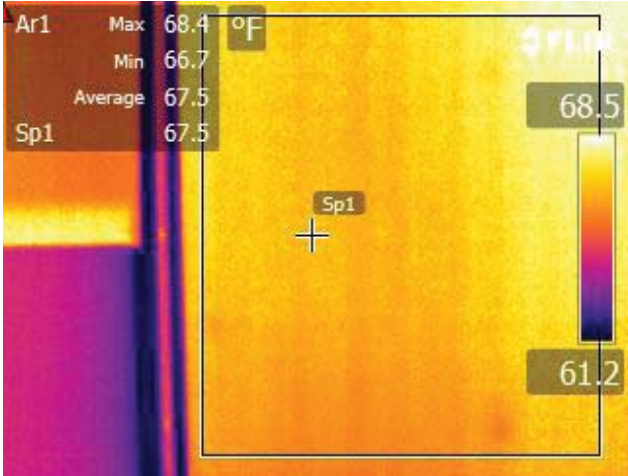

Infrared Image

APPENDIX- 06b | WINDOW TRANSITIONS: Recessed Relationship with Thermal Barrier

Project Conditions

Location: Eastern Massachusetts
 Date of Thermal Image: 02/21/2012
 Exterior Air Temperature: 37.7 °F
 Interior Air Temperature: 69.9 °F
 Radiant Temperature: N/A °F
 Assumed Emissivity: 0.9

Summary of Thermal Performance

Calculated Baseline R-Value: 13.86 -
As-Built Condition
 Thermal Image R-Value: N/A
 Simulated (THERM) R-Value: 8.76 - 37 %
Thermally Improved Condition
 Simulated (THERM) R-Value: 11.16 - 19 %

As-Built Condition

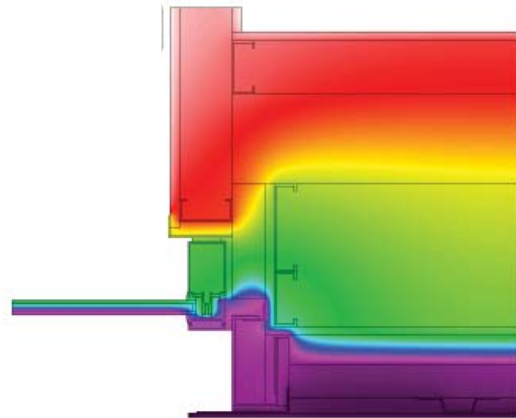
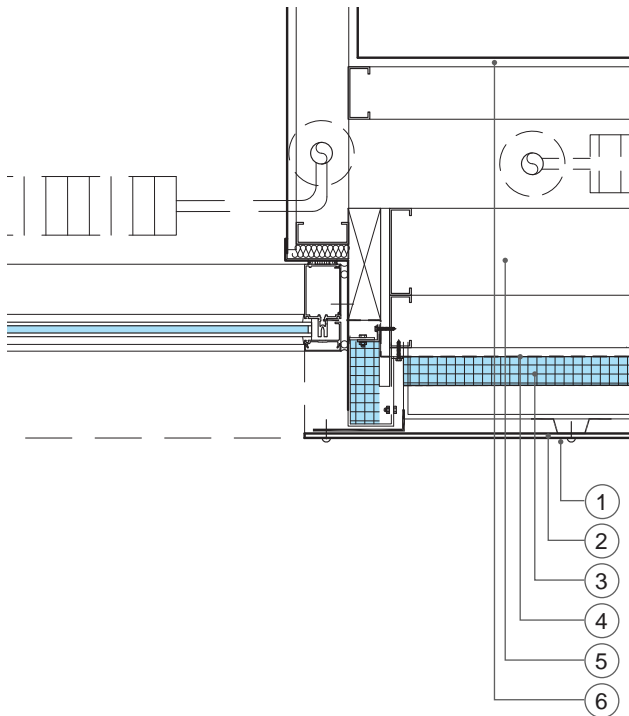

R-8.76

Calculated Baseline Clear Wall R-value									
	Material	Width in.	<i>k</i> Btu·in/h·ft ² ·°F	R-value h·ft ² ·°F/Btu		Material	Width in.	<i>k</i> Btu·in/h·ft ² ·°F	R-value h·ft ² ·°F/Btu
-	Exterior Air Film	-	-	-	(4)	Exterior Sheathing	0.625	1.10	0.57
(1)	Cement Panel	-	-	-	(5)	Air Cavity	-	-	1.36
(2)	Exterior Air Film	-	-	0.68	(6)	Gypsum Board	0.625	1.10	0.57
(3)	Rigid Insulation	2.00	0.20	10.00	-	Interior Air Film	-	-	0.68
								total	13.86

Thermally Improved Condition

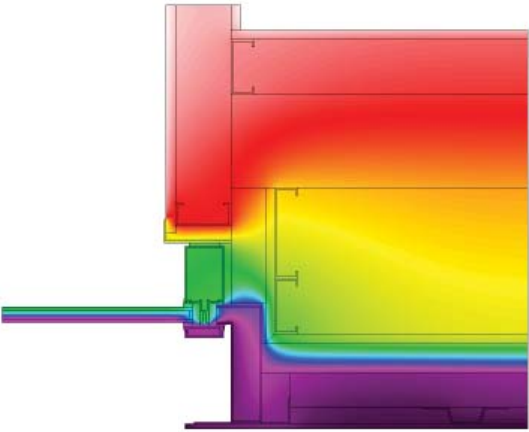
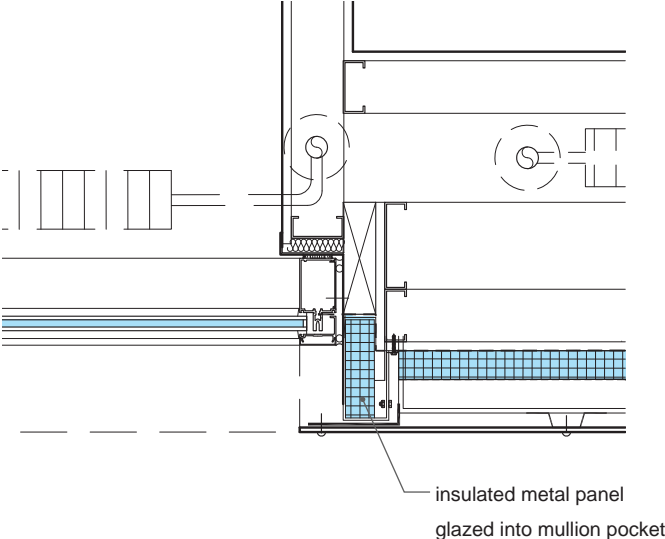

R-11.16
(+27%)

APPENDIX- 06c | WINDOW TRANSITIONS: Recessed Relationship with Thermal Barrier

Project Conditions

Location: Central Rhode Island
 Date of Thermal Image: 02/21/2012
 Exterior Air Temperature: 25.7 °F
 Interior Air Temperature: 68.4 °F
 Radiant Temperature: 69.7 °F
 Assumed Emissivity: 0.9

Summary of Thermal Performance

Calculated Baseline R-Value: 19.82 -
As-Built Condition
 Thermal Image R-Value: 8.91 - 55 %
 Simulated (THERM) R-Value: 3.15 - 84 %
Thermally Improved Condition
 Simulated (THERM) R-Value: 7.08 - 64 %

As-Built Condition

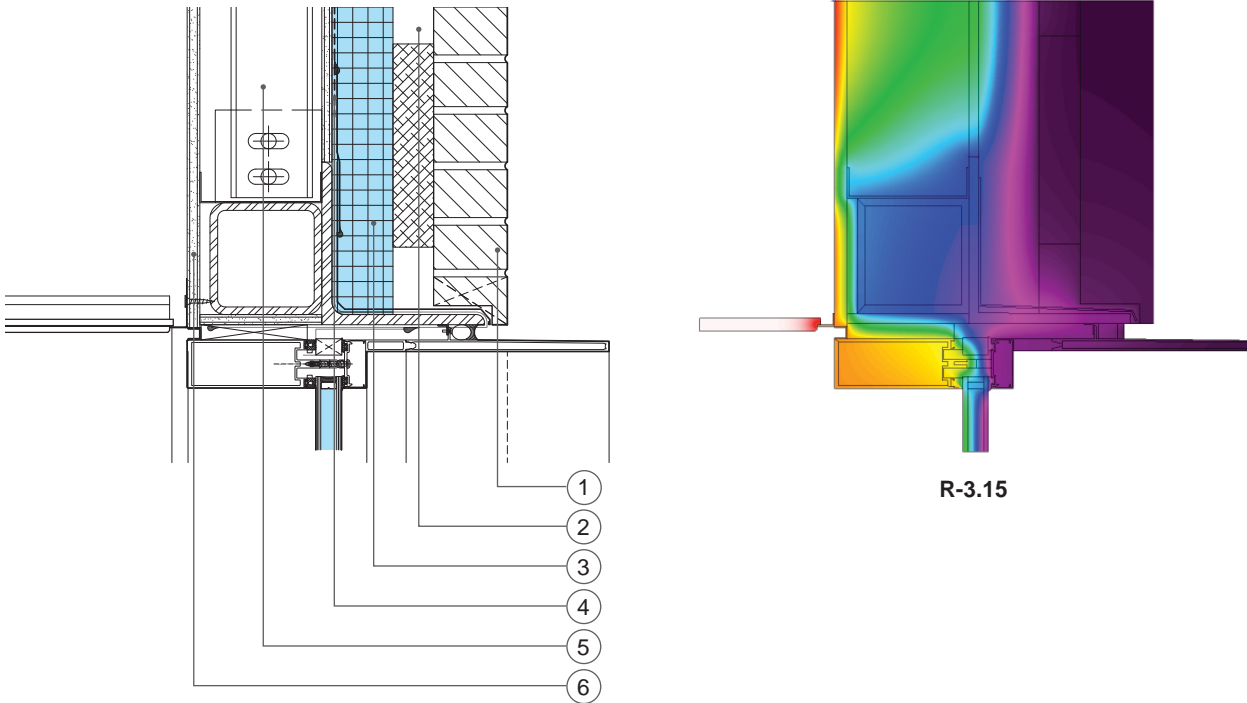

Calculated Baseline Clear Wall R-value									
	Material	Width in.	<i>k</i> Btu-in/h-ft ² ·°F	R-value h-ft ² ·°F/Btu		Material	Width in.	<i>k</i> Btu-in/h-ft ² ·°F	R-value h-ft ² ·°F/Btu
-	Exterior Air Film	-	-	0.17	(4)	Exterior Sheathing	0.50	1.10	0.45
(1)	Brick (Common)	3.625	6.19	0.59	(5)	Air Cavity	-	-	1.36
(2)	Air Cavity	-	-	1.00	(6)	Gypsum Board	0.625	1.10	0.57
(3)	Rigid Insulation	3.00	0.20	15.00	-	Interior Air Film	-	-	0.68
								total	19.82

APPENDIX- 06c | WINDOW TRANSITIONS: Recessed Relationship with Thermal Barrier



Digital Image



Infrared Image

Thermally Improved Condition

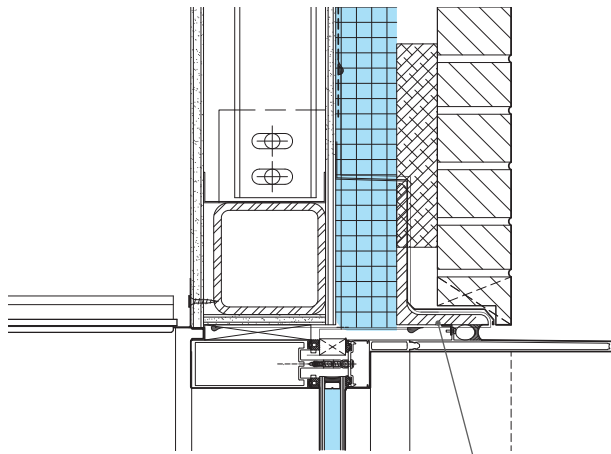

brick lintel pulled outside of insulation with intermittent bracing back to structural steel tube

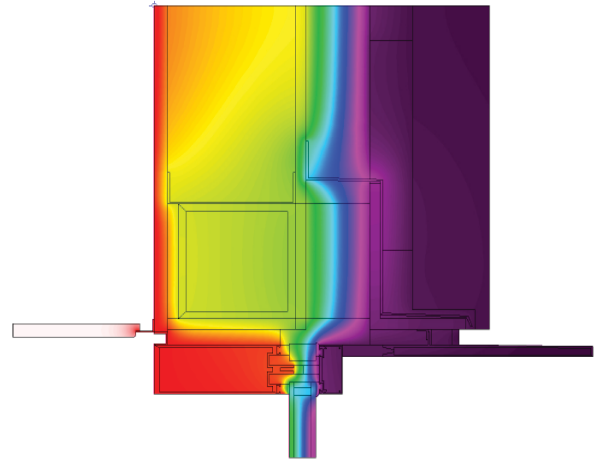

R-7.08
(+125%)

APPENDIX- 06d | WINDOW TRANSITIONS: Proud Relationship with Thermal Barrier

Project Conditions

Location: Southeastern Massachusetts
 Date of Thermal Image: 02/09/2012
 Exterior Air Temperature: 37.7 °F
 Interior Air Temperature: 71.7 °F
 Radiant Temperature: 72.9 °F
 Assumed Emissivity: 0.9

Summary of Thermal Performance

Calculated Baseline R-Value: 19.86 -

As-Built Condition

Thermal Image R-Value: N/A
 Simulated (THERM) R-Value: see details below

Thermally Improved Condition

Simulated (THERM) R-Value: see details below

As-Built Condition

Section Detail

Plan Detail

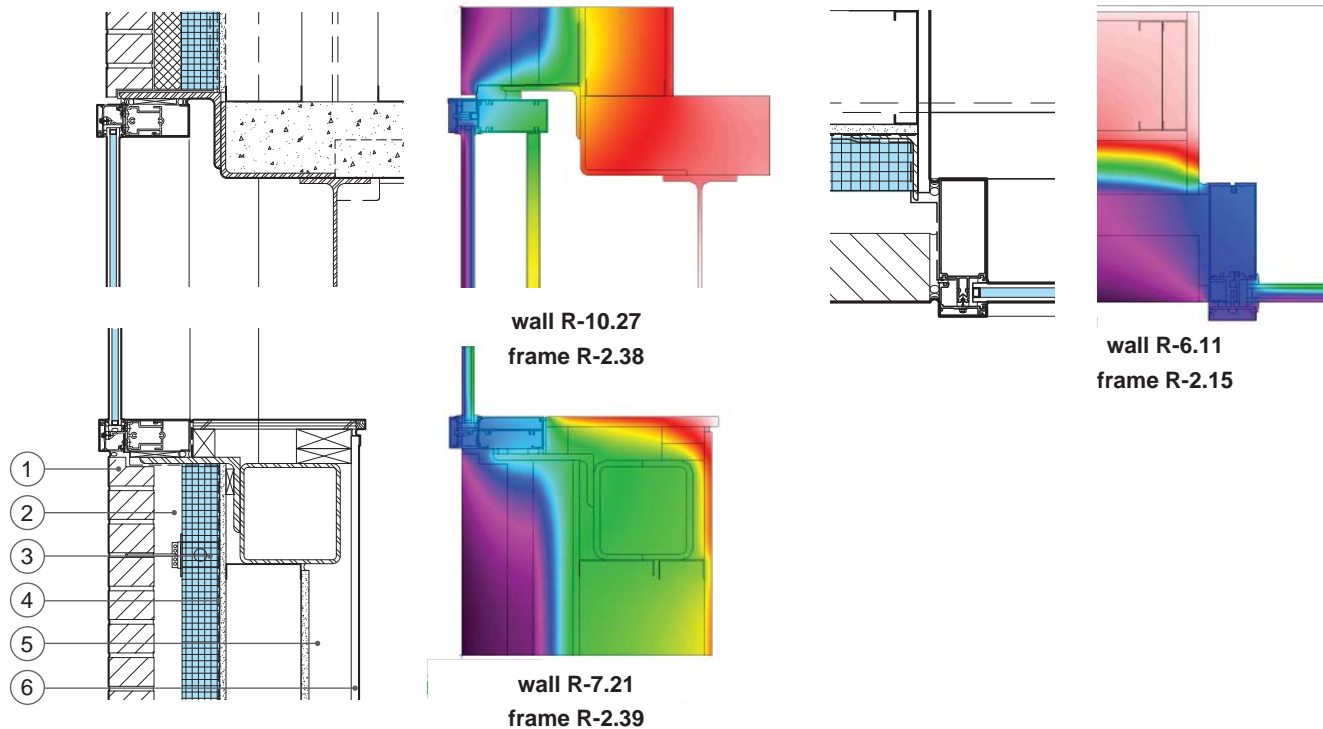

Calculated Baseline Clear Wall R-value									
	Material	Width in.	<i>k</i> Btu·in/h·ft ² ·°F	R-value h·ft ² ·°F/Btu		Material	Width in.	<i>k</i> Btu·in/h·ft ² ·°F	R-value h·ft ² ·°F/Btu
-	Exterior Air Film	-	-	0.17	(4)	Exterior Sheathing	0.625	1.10	0.57
(1)	Brick (Common)	3.625	6.20	0.58	(5)	Air Cavity	-	-	1.36
(2)	Air Cavity	-	-	1.00	(6)	Gypsum Board	0.625	1.10	0.57
(3)	Rigid Insulation	3.00	0.20	14.93	-	Interior Air Film	-	-	0.68
								total	19.86

APPENDIX- 06d | WINDOW TRANSITIONS: Proud Relationship with Thermal Barrier

Thermally Improved Condition

Section Detail

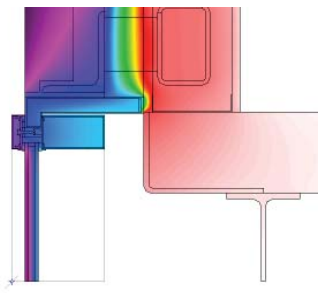
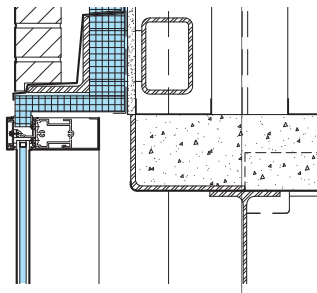

frame R-4.02
(+41%)

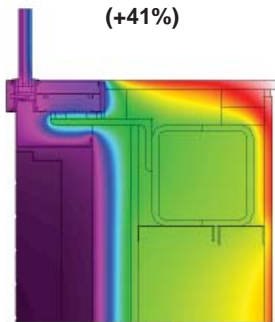
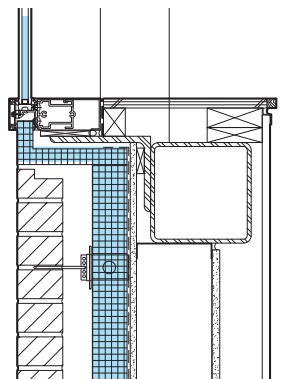

frame R-4.28
(+44%)

Plan Detail

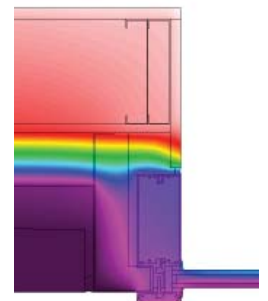
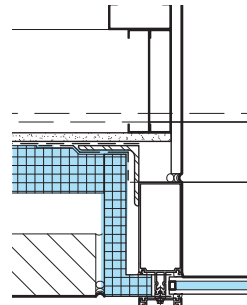

frame R-3.46
(+38%)

APPENDIX- 06e | WINDOW TRANSITIONS: Proud Relationship with Thermal Barrier

Project Conditions

Location: Southeastern Massachusetts
 Date of Thermal Image: 02/09/2012
 Exterior Air Temperature: 37.7 °F
 Interior Air Temperature: 71.7 °F
 Radiant Temperature: 72.9 °F
 Assumed Emissivity: 0.9

Summary of Thermal Performance

Calculated Baseline R-Value: 18.78 -
As-Built Condition
 Thermal Image R-Value: 8.58 - 54 %
 Simulated (THERM) R-Value:
 Head 10.48 - 44 %
 Jamb 9.36 - 50 %
 Sill 10.39 - 45 %

As-Built Condition

Section Detail

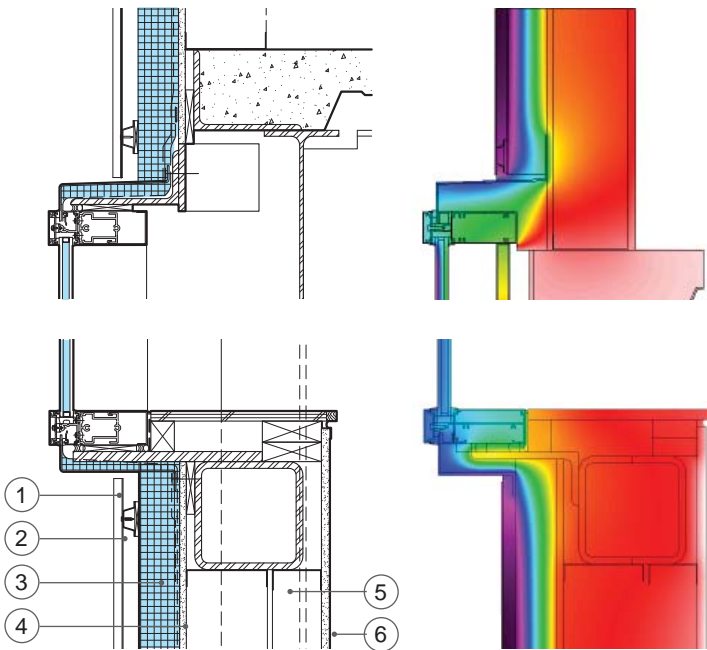

Plan Detail

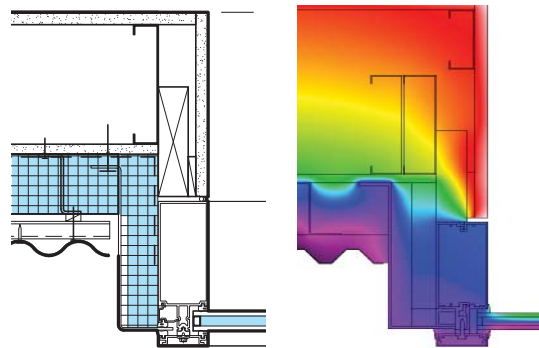

Calculated Baseline Clear Wall R-value									
	Material	Width in.	<i>k</i> Btu·in/h·ft ² ·°F	R-value h·ft ² ·°F/Btu		Material	Width in.	<i>k</i> Btu·in/h·ft ² ·°F	R-value h·ft ² ·°F/Btu
①	Corrugated Metal	-	-	-	④	Exterior Sheathing	0.625	1.10	0.57
②	Air Space	-	-	-	⑤	Air Cavity	-	-	1.36
-	Exterior Air Film	-	-	0.68	⑥	Gypsum Board	0.625	1.10	0.57
③	Rigid Insulation	3.00	0.20	14.93	-	Interior Air Film	-	-	0.68
								total	18.78

APPENDIX- 06e | WINDOW TRANSITIONS: Proud Relationship with Thermal Barrier



Digital Image

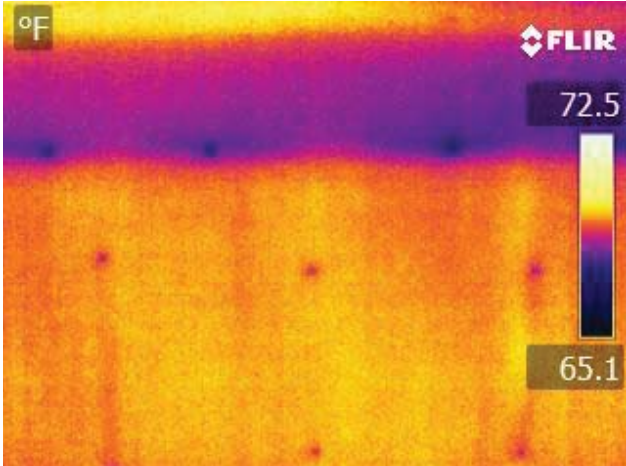

Infrared Image

APPENDIX- 06f | WINDOW TRANSITIONS: Inline Relationship with Thermal Barrier

Project Conditions

Location: Souther Massachusetts
 Date of Thermal Image: 02/09/2012
 Exterior Air Temperature: 32.3 °F
 Interior Air Temperature: 71.0 °F
 Radiant Temperature: 71.5 °F
 Assumed Emissivity: 0.9

Summary of Thermal Performance

Calculated Baseline R-Value: 13.86 -
As-Built Condition
 Thermal Image R-Value: 7.50 - 46 %
 Simulated (THERM) R-Value:
 Head 6.46 - 53 %
 Jamb 7.65 - 45 %
 Sill 6.46 - 53 %

As-Built Condition

Section Detail

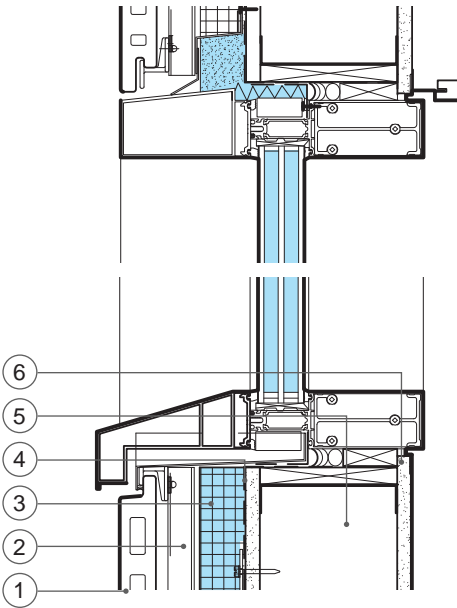

Plan Detail

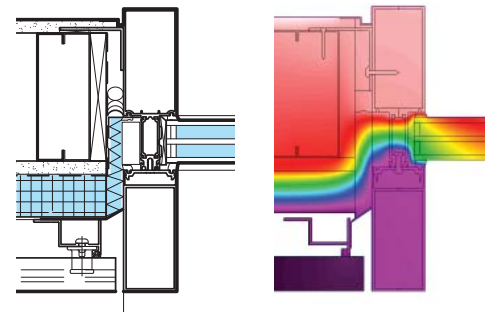

Calculated Baseline Clear Wall R-value									
	Material	Width in.	<i>k</i> Btu-in/h-ft ² ·°F	R-value h-ft ² ·°F/Btu		Material	Width in.	<i>k</i> Btu-in/h-ft ² ·°F	R-value h-ft ² ·°F/Btu
①	Terracotta Tile	-	-	-	④	Exterior Sheathing	0.625	1.10	0.57
②	Air Cavity	-	-	-	⑤	Air Cavity	-	-	1.36
-	Exterior Air Film	-	-	0.68	⑥	Gypsum Board	0.625	1.10	0.57
③	Rigid Insulation	2.00	0.20	10.00	-	Interior Air Film	-	-	0.68
								total	13.86

APPENDIX- 06f | WINDOW TRANSITIONS: Inline Relationship with Thermal Barrier



Digital Image

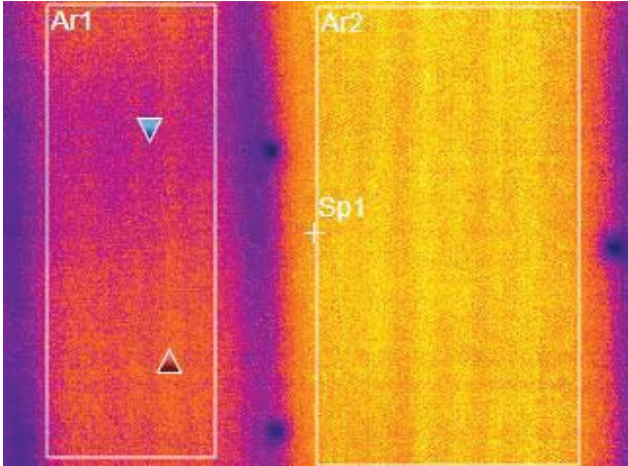

Infrared Image

APPENDIX- 06g | WINDOW TRANSITIONS: Inline Relationship with Thermal Barrier

Project Conditions

Location: Souther Connecticut
 Date of Thermal Image: 03/14/2013
 Exterior Air Temperature: 36.0 °F
 Interior Air Temperature: 67.3 °F
 Radiant Temperature: 68.4 °F
 Assumed Emissivity: 0.9

Summary of Thermal Performance

Calculated Baseline R-Value: 20.74 -
As-Built Condition
 Thermal Image R-Value: 7.94 - 62 %
 Simulated (THERM) R-Value: 7.12 - 66 %

As-Built Condition

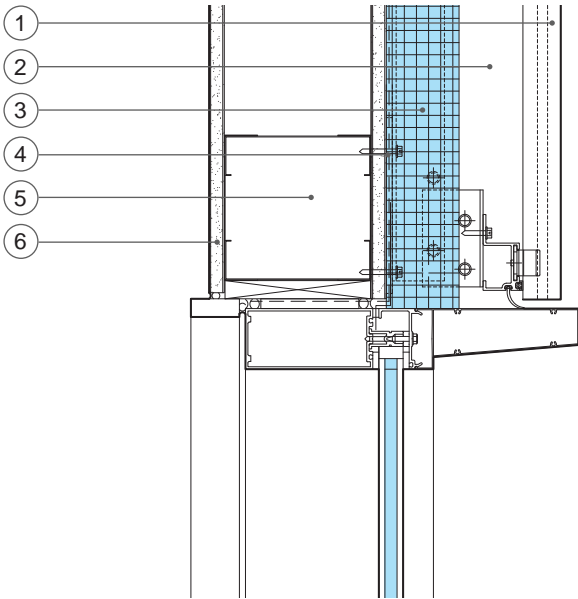

Calculated Baseline Clear Wall R-value									
	Material	Width in.	<i>k</i> Btu-in/h-ft ² ·°F	R-value h-ft ² ·°F/Btu		Material	Width in.	<i>k</i> Btu-in/h-ft ² ·°F	R-value h-ft ² ·°F/Btu
①	Terracotta Tile	-	-	-	④	Exterior Sheathing	0.50	1.10	0.45
②	Air Cavity	-	-	-	⑤	Air Cavity	-	-	1.36
-	Exterior Air Film	-	-	0.68	⑥	Gypsum Board	0.625	1.10	0.57
③	Mineral Wool	4.00	0.23	17	-	Interior Air Film	-	-	0.68
								total	20.74

APPENDIX- 06g | WINDOW TRANSITIONS: Inline Relationship with Thermal Barrier



Digital Image

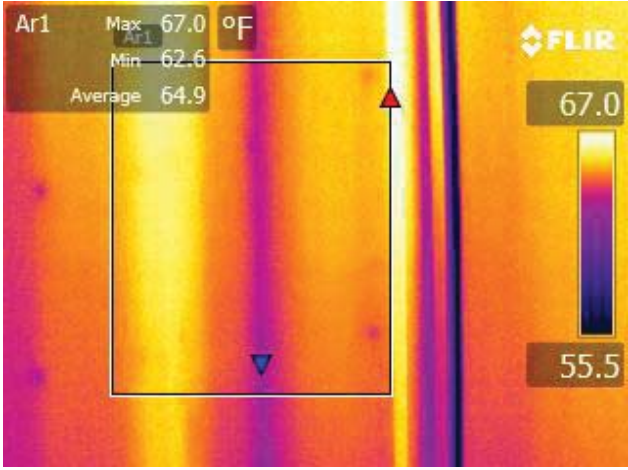

Infrared Image

APPENDIX- 06h | WINDOW TRANSITIONS: Inline Relationship with Thermal Barrier

Project Conditions

Location: Western New Hampshire
 Date of Thermal Image: 03/21/2013
 Exterior Air Temperature: 32.1 °F
 Interior Air Temperature: 70.5 °F
 Radiant Temperature: 73.8 °F
 Assumed Emissivity: 0.9

Summary of Thermal Performance

Calculated Baseline R-Value: 22.85 -
As-Built Condition
 Thermal Image R-Value: 9.14 - 60 %
 Simulated (THERM) R-Value: 9.57 - 58 %

As-Built Condition

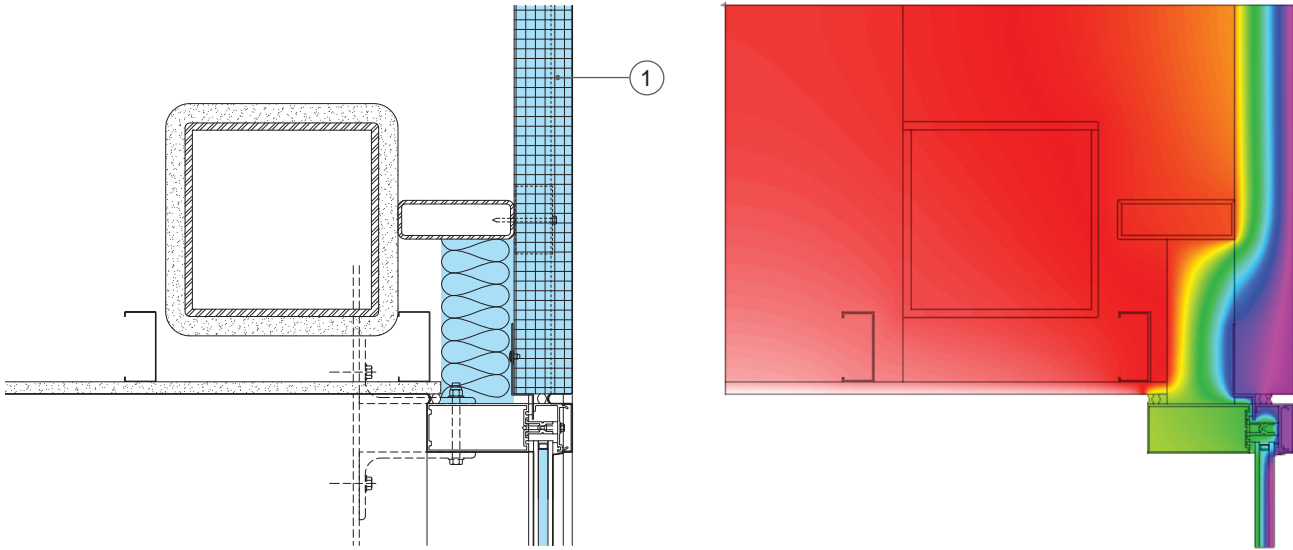

Calculated Baseline Clear Wall R-value									
	Material	Width in.	k Btu·in/h·ft ² ·°F	R-value h·ft ² ·°F/Btu		Material	Width in.	k Btu·in/h·ft ² ·°F	R-value h·ft ² ·°F/Btu
-	-	-	-	-	-	-	-	-	-
-	-	-	-	-	-	Exterior Air Film	-	-	0.17
-	-	-	-	-	①	Insulated Metal Panel	3.00	0.14	22.00
-	-	-	-	-	-	Interior Air Film	-	-	0.68
								total	22.85

APPENDIX- 06h | WINDOW TRANSITIONS: Inline Relationship with Thermal Barrier



Digital Image

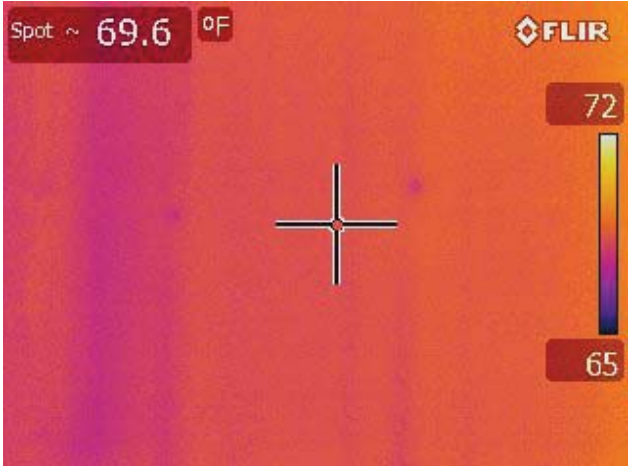

Infrared Image

APPENDIX- 07a | FOUNDATION TO WALL TRANSITIONS: Foundation Wall Transition 1

Project Conditions

Location: Western Massachusetts
 Date of Thermal Image: 02/27/2012
 Exterior Air Temperature: 46 °F
 Interior Air Temperature: 69 °F
 Radiant Temperature: 69.6 °F
 Assumed Emissivity: 0.9

Summary of Thermal Performance

Calculated Baseline R-Value: 14.01 -

As-Built Condition

Thermal Image R-Value: 3.71 - 74 %
 Simulated (THERM) R-Value (wall): 8.39 - 40 %
 Simulated (THERM) R-Value (floor): 26.8 -

Thermally Improved Condition

Simulated (THERM) R-Value: N/A N/A

As-Built Condition

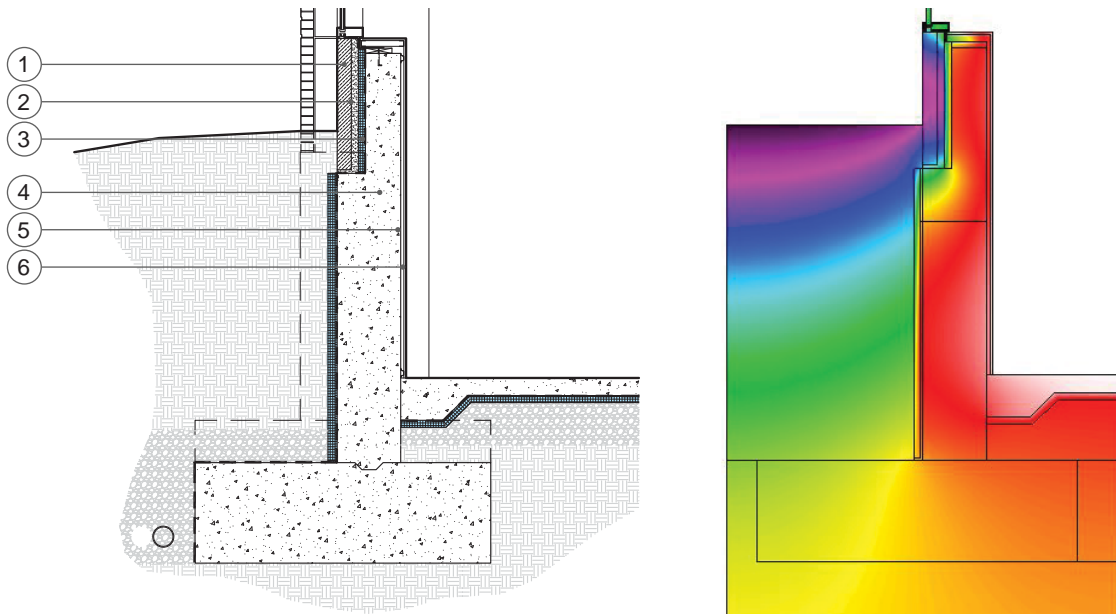

Calculated Baseline Clear Wall R-value									
	Material	Width in.	k Btu-in/h-ft ² ·°F	R-value h-ft ² ·°F/Btu		Material	Width in.	k Btu-in/h-ft ² ·°F	R-value h-ft ² ·°F/Btu
-	Exterior Air Film	-	-	0.17	(4)	Concrete	10	12.5	0.80
(1)	Granite	4	30	0.13	(5)	Air Cavity	0.875	-	1.36
(2)	Grout	2	6.7	0.30	(6)	Gypsum Board	0.625	1.1	0.57
(3)	Extruded Polystyrene	2	0.20	10	-	Interior Air Film	-	-	0.68
								total	14.01

APPENDIX- 07a | FOUNDATION TO WALL TRANSITION: Foundation Wall Transition 1

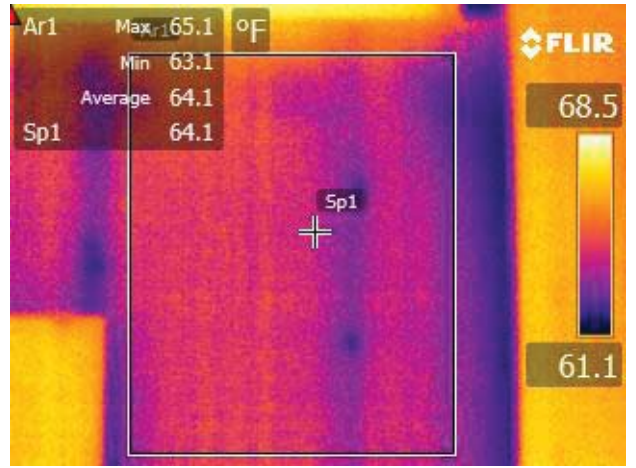

APPENDIX- 07b | FOUNDATION TO WALL TRANSITIONS: Foundation Wall Transition 2

Project Conditions

Location: Western Massachusetts
 Date of Thermal Image: 02/21/2012
 Exterior Air Temperature: 37.3 °F
 Interior Air Temperature: 71 °F
 Radiant Temperature: 69.5 °F
 Assumed Emissivity: 0.9

Summary of Thermal Performance

Calculated Baseline R-Value: 13.74 -

As-Built Condition

Thermal Image R-Value: 3.5 - 74.5 %
 Simulated (THERM) R-Value (wall): 5.8 - 57.8 %
 Simulated (THERM) R-Value (floor): 3.2 -

Thermally Improved Condition

Simulated (THERM) R-Value (wall): 6.1 -55.6 %
 Simulated (THERM) R-Value (floor): 5.85 -

As-Built Condition

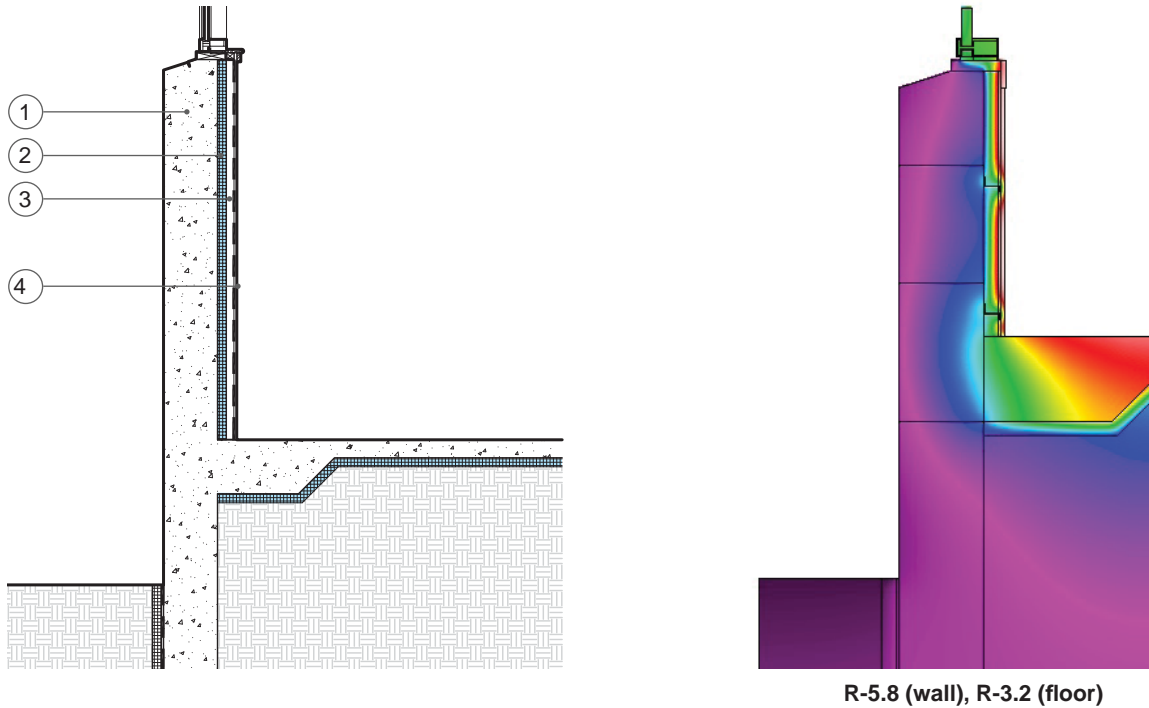

Calculated Baseline Clear Wall R-value									
	Material	Width in.	<i>k</i> Btu·in/h·ft ² ·°F	R-value h·ft ² ·°F/Btu		Material	Width in.	<i>k</i> Btu·in/h·ft ² ·°F	R-value h·ft ² ·°F/Btu
-	Exterior Air Film	-	-	0.17	④	Gypsum Board	0.625	1.10	0.57
①	Architectural Concrete	12	12.5	0.96	-	Interior Air Film	-	-	0.68
②	Extruded Polystyrene	2	0.20	10					
③	Air Cavity	-	-	1.36					
								total	13.74

APPENDIX- 07b | FOUNDATION TO WALL TRANSITIONS: Foundation Wall Transition 2

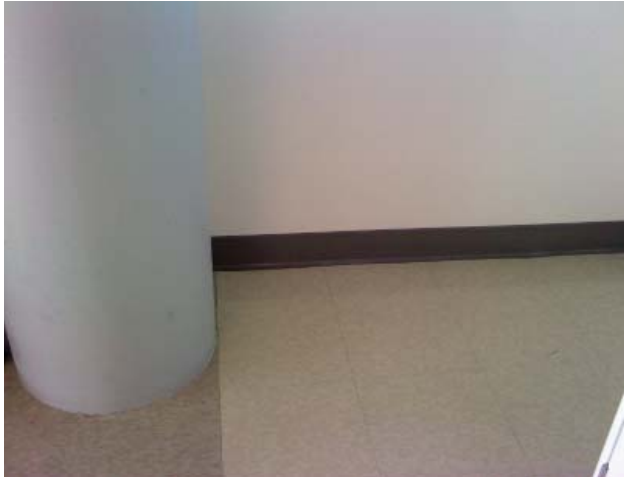

Digital Image

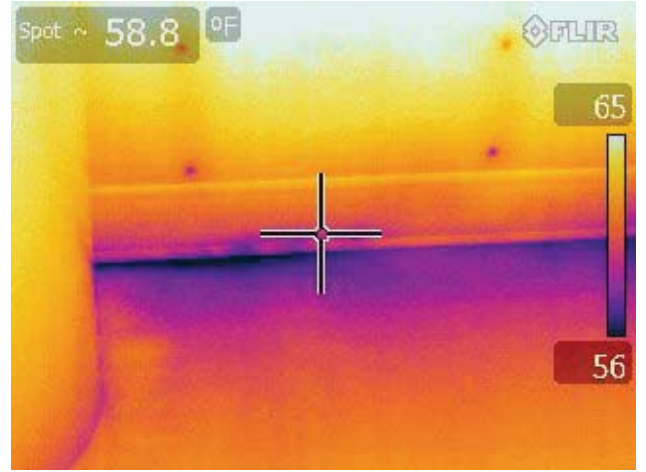

Infrared Image

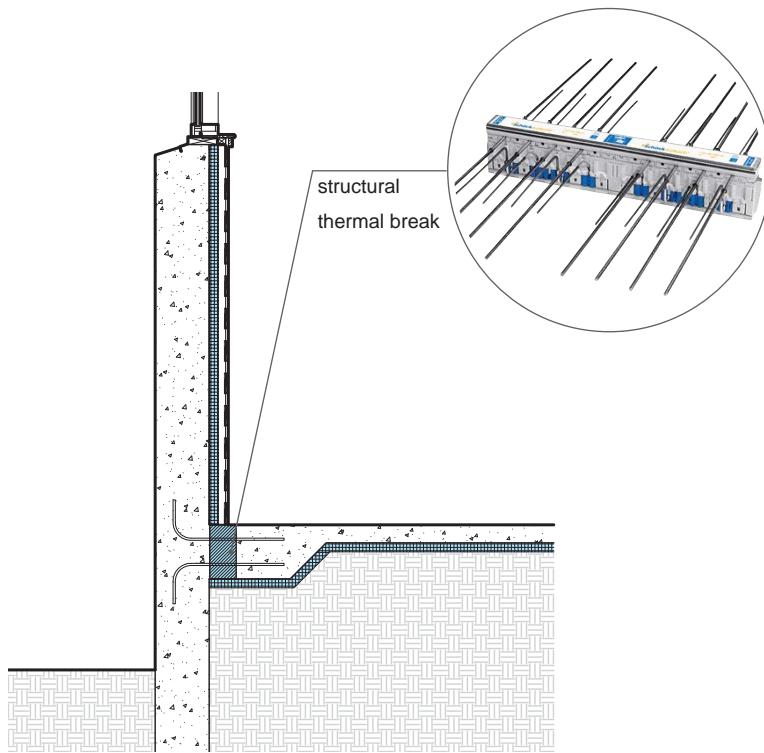

Thermally Improved Condition

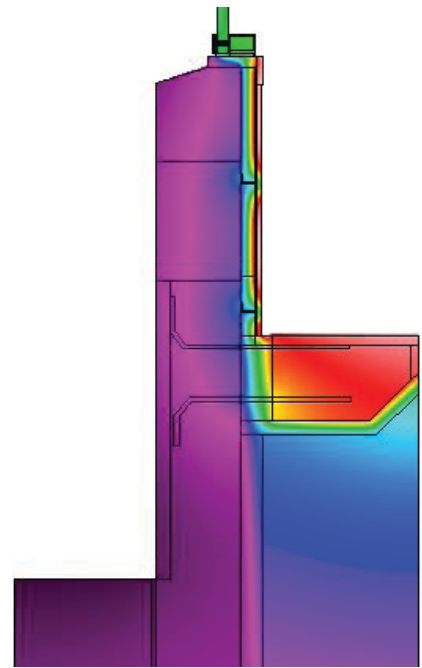

R-6.1 (wall), R-5.85 (floor)
(+5% wall, +82.8% floor)

APPENDIX- 07c | FOUNDATION TO WALL TRANSITIONS: Foundation Wall Transition 3

Project Conditions

Location: Massachusetts
 Date of Thermal Image: 02/27/2012
 Exterior Air Temperature: 43.8 °F
 Interior Air Temperature: 70.4 °F
 Radiant Temperature: 70.8 °F
 Assumed Emissivity: 0.9

Summary of Thermal Performance

Calculated Baseline R-Value: 13.86 -

As-Built Condition

Thermal Image R-Value: 4.13 - 70 %
 Simulated (THERM) R-Value (wall): 5.94 - 57 %
 Simulated (THERM) R-Value (floor): 5.01 -

Thermally Improved Condition

Simulated (THERM) R-Value: N/A N/A

As-Built Condition

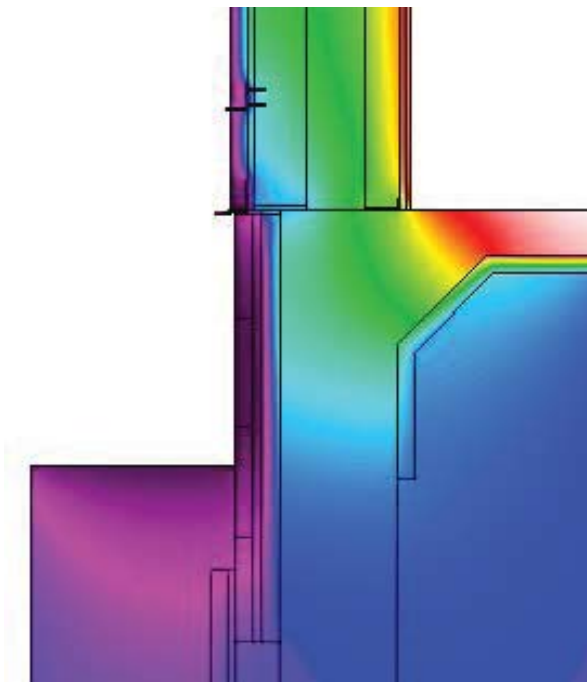
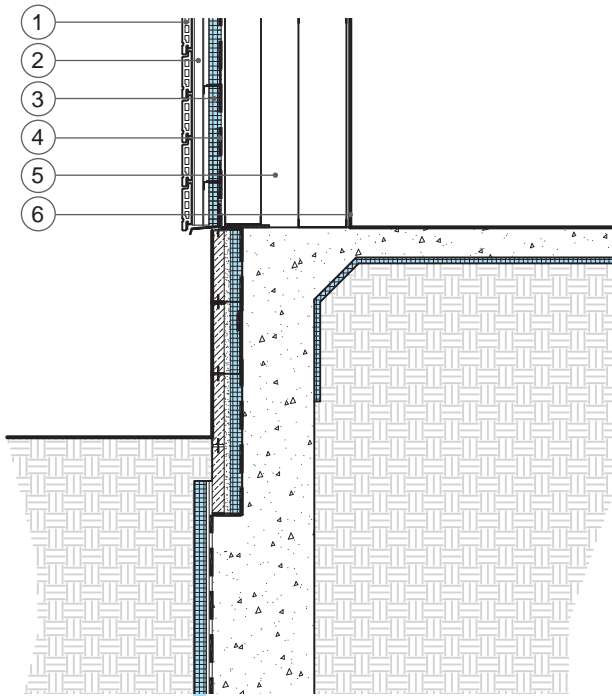

Calculated Baseline Clear Wall R-value									
	Material	Width in.	<i>k</i> Btu-in/h-ft ² ·°F	R-value h-ft ² ·°F/Btu		Material	Width in.	<i>k</i> Btu-in/h-ft ² ·°F	R-value h-ft ² ·°F/Btu
①	Terracotta Tile	-	-	-	④	Exterior Sheathing	0.625	1.10	0.57
②	Air Cavity	-	-	-	⑤	Air Cavity	15	-	1.36
-	Exterior Air Film	-	-	0.68	⑥	Gypsum Board	0.625	1.10	0.57
③	Extruded Polystyrene	2	0.20	10.00	-	Interior Air Film	-	-	0.68
								total	13.86

APPENDIX- 07c | FOUNDATION TO WALL TRANSITIONS: Foundation Wall Transition 3



Digital Image

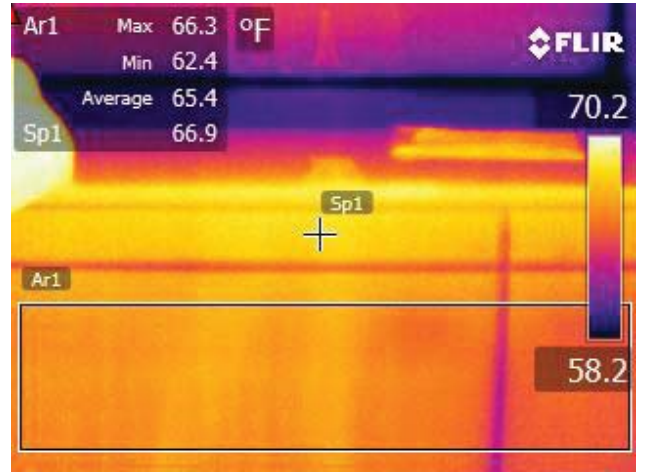

Infrared Image

APPENDIX- 07d | FOUNDATION TO WALL TRANSITIONS: Foundation Wall Transition 4

Project Conditions

Location: New Hampshire
 Date of Thermal Image: 3/21/2013
 Exterior Air Temperature: 30 °F
 Interior Air Temperature: 68 °F
 Radiant Temperature: 67.5 °F
 Assumed Emissivity: 0.9

Summary of Thermal Performance

Calculated Baseline R-Value: 13.38 -

As-Built Condition

Simulated (THERM) R-Value (wall): 4.10 - 69 %
 Simulated (THERM) R-Value (floor): 10.88 -

Thermally Improved Condition

See 07e

As-Built Condition

As-Built Condition

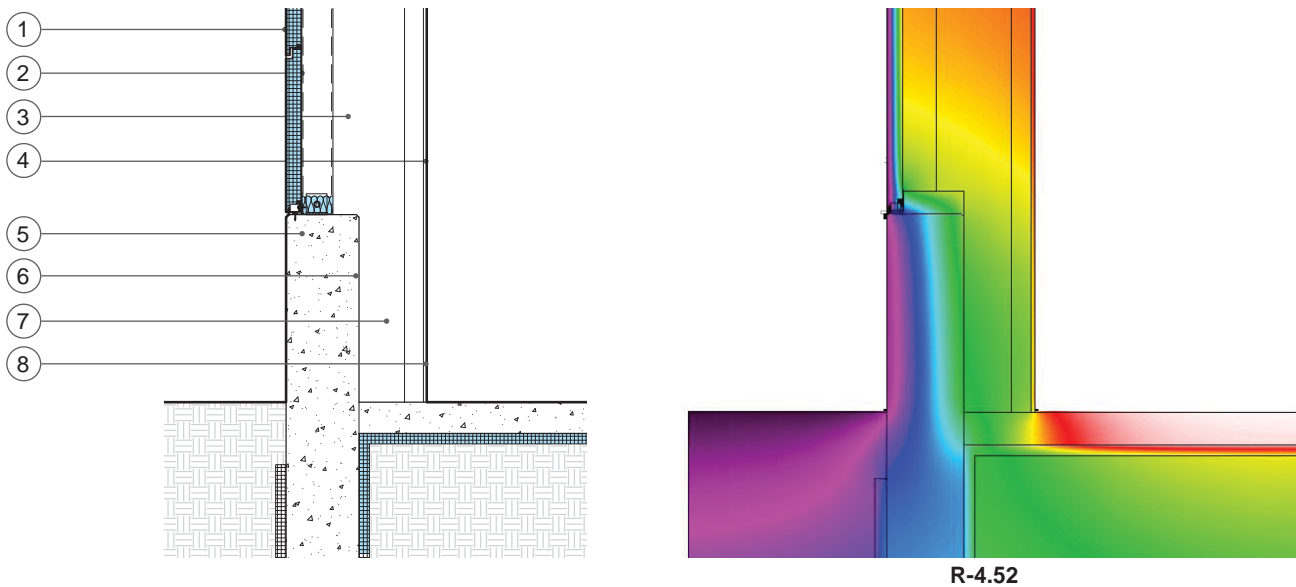

Calculated Baseline Clear Wall R-value (at Metal Panel)					Calculated Baseline Clear Wall R-value (at Concrete)				
	Material	Width in.	k Btu-in/h-ft2-°F	R-value h-ft2-°F/Btu		Material	Width in.	k Btu-in/h-ft2-°F	R-value h-ft2-°F/Btu
-	Exterior Air Film	-	-	0.17	-	Exterior Air Film	-	-	0.17
①	Insulated Metal Panel	3	.153	19.5	⑤	Concrete	8	12.5	.64
②	Air and Vapor Barrier	-	-	-	⑥	Air and Vapor Barrier	-	-	-
③	Air Cavity	12	-	-	⑦	Air Cavity	8	-	-
④	Gypsum Board	0.625	1.1	0.57	⑧	Gypsum Board	0.625	1.1	0.57
-	Interior Air Film	-	-	.68	-	Interior Air Film	-	-	.68
				total wall (MP)	20.92				
						total wall (C)			
						Composite wall value (.6*MP+.4*C)			
						13.38			



APPENDIX- 07e | FOUNDATION TO WALL TRANSITIONS: Foundation Wall Transition 5

Project Conditions

Location: New Hampshire
 Date of Thermal Image: 3/21/2013
 Exterior Air Temperature: 30 °F
 Interior Air Temperature: 68 °F
 Radiant Temperature: 67.5 °F
 Assumed Emissivity: 0.9

Thermally Improved option A

Summary of Thermal Performance

As-Built Condition (See 07b)
 Simulated (THERM) R-Value (wall): 4.10
 Simulated (THERM) R-Value (floor): 10.88

Thermally Improved Condition
 Calculated Baseline R-Value A: 18.19
 Simulated (THERM) R-Value A (wall): 8.59
 Simulated (THERM) R-Value A (floor): 14.21

Calculated Baseline R-Value B: 18.74
 Simulated (THERM) R-Value B (wall): 9.82
 Simulated (THERM) R-Value B (floor): 18.36

Thermally Improved Option A

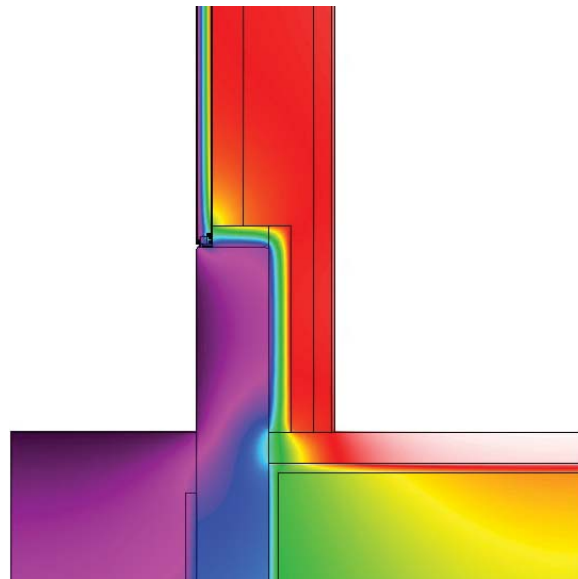
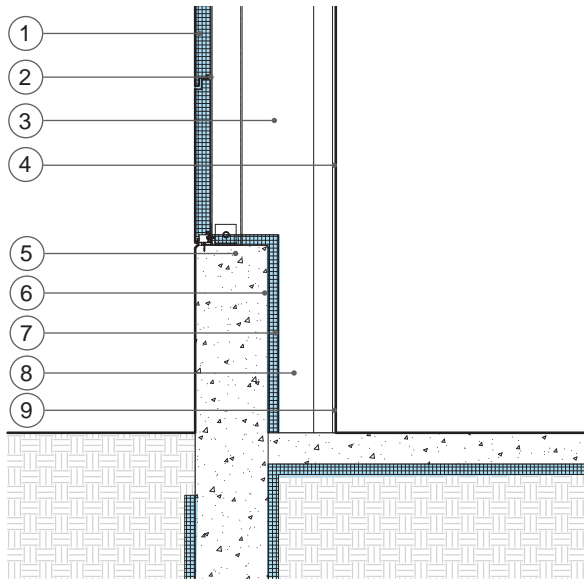

R-8.59 (wall), R-14.21 (floor)
 (+109% wall, +30.6% floor)

Calculated Baseline Clear Wall R-value (at Metal Panel)					Calculated Baseline Clear Wall R-value (at Concrete)				
	Material	Width in.	k Btu-in/h-ft2·°F	R-value h-ft2·°F/Btu		Material	Width in.	k Btu-in/h-ft2·°F	R-value h-ft2·°F/Btu
-	Exterior Air Film	-	-	0.17	-	Exterior Air Film	-	-	0.17
①	Insulated Metal Panel	3	.153	19.5	⑤	Concrete	8	12.5	.64
②	Air and Vapor Barrier	-	-	-	⑥	Air and Vapor Barrier	-	-	-
③	Air Cavity	12	-	1.36	⑦	Rigid Insulation	2	.2	10
④	Gypsum Board	0.625	1.1	0.57	⑧	Air Cavity	-	-	-
-	Interior Air Film	-	-	.68	⑨	Gypsum Board	0.625	1.1	0.57
					-	Interior Air Film	-	-	.68
				total wall (MP)	22.28				
						total wall (C)			
						Composite wall value (.6*MP+.4*C)			
						18.19			

Thermally Improved Option B

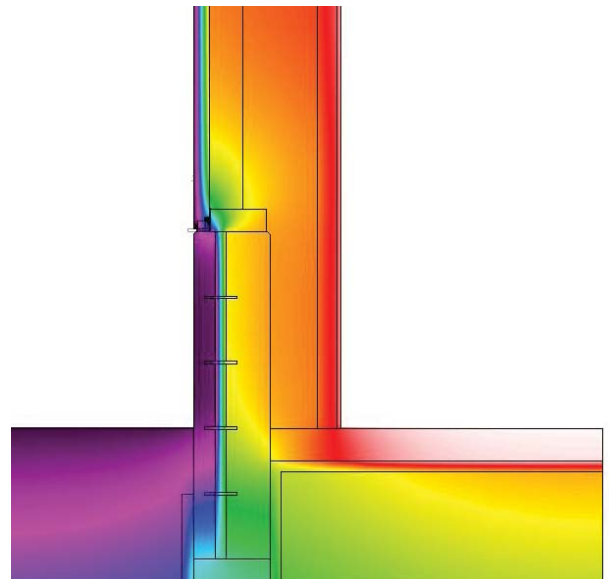
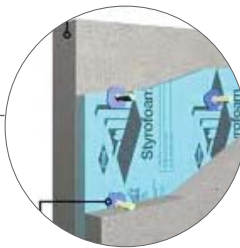
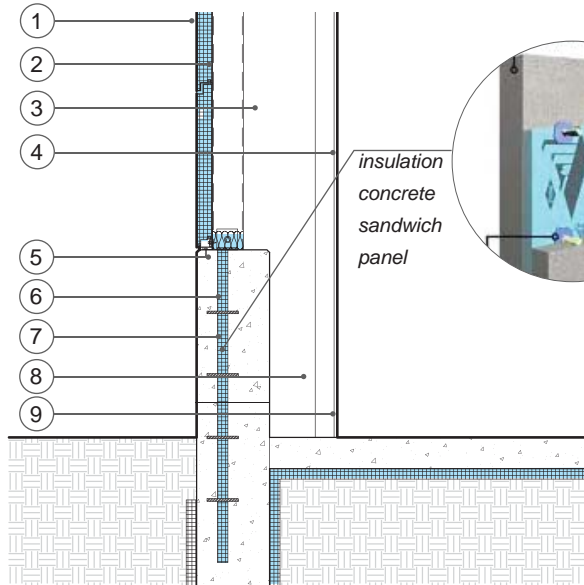

R-9.82 (wall), R-18.36 (floor)
 (+139% wall, +68.8% floor)

Calculated Baseline Clear Wall R-value (at Metal Panel)					Calculated Baseline Clear Wall R-value (at Concrete)						
	Material	Width in.	k Btu-in/h-ft ² ·°F	R-value h-ft ² ·°F/Btu		Material	Width in.	k Btu-in/h-ft ² ·°F	R-value h-ft ² ·°F/Btu		
-	Exterior Air Film	-	-	0.17	-	Exterior Air Film	-	-	0.17		
①	Insulated Metal Panel	3	.153	19.5	⑤	Concrete	8	12.5	.64		
②	Air and Vapor Barrier			-	⑥	Air and Vapor Barrier			-		
③	Air Cavity	12		1.36	⑦	Rigid Insulation	2	.2	10		
④	Gypsum Board	0.625	1.1	0.57	⑧	Air Cavity			1.36		
-	Interior Air Film	-	-	.68	⑨	Gypsum Board	0.625	1.1	0.57		
-					-	Interior Air Film	-	-	.68		
				total wall (MP)	22.28					total wall (C)	13.42
Composite wall value (.6*MP+.4*C)										18.74	

APPENDIX- 07f | FOUNDATION TO WALL TRANSITIONS: Foundation Wall Sandwich Panel Study

Parapet Height Study

This study works with limited variables to see whether the location of the insulation within the concrete sandwich panel would make a noticeable difference thermally.

Summary of Thermal Performance

Calculated Baseline R-Value A (wall):	23.9	
Simulated (THERM) R-Value A (wall):	23.5	-2 %
Calculated Baseline R-Value B (wall):	23.9	
Simulated (THERM) R-Value B (wall):	23.15	-3 %

Sandwich panel foundation wall (A)
(4" Conc. + 4" Insul. + 10" Conc.)

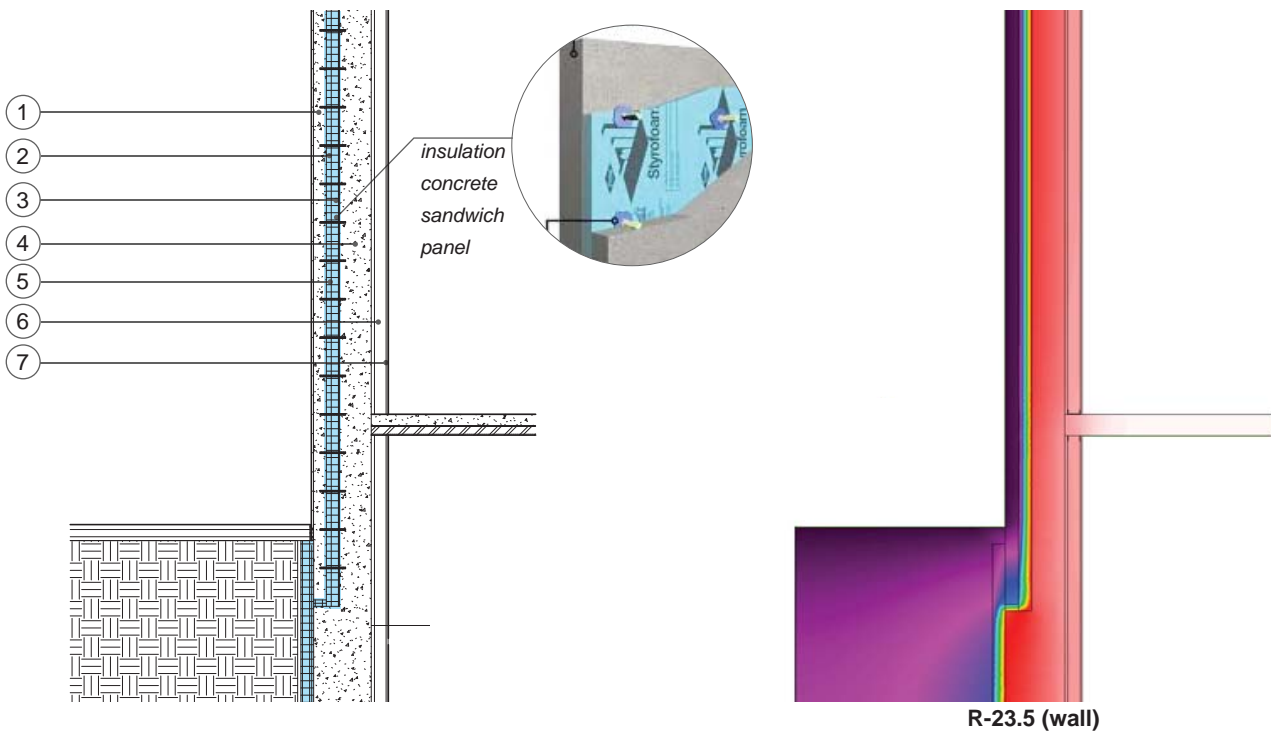

Calculated Baseline Clear Wall R-value									
	Material	Width in.	k Btu-in/h-ft ² ·°F	R-value h-ft ² ·°F/Btu		Material	Width in.	k Btu-in/h-ft ² ·°F	R-value h-ft ² ·°F/Btu
-	Exterior Air Film	-	-	0.17	(5)	Composite Ties	-	.25	-
(1)	Concrete	4	12.5	.32	(6)	Air Cavity	-	-	1.36
(2)	Rigid Insulation	4	.2	20	(7)	Gypsum Board	0.625	1.1	0.57
(3)	Air and Vapor Barrier	-	-	-	-	Interior Air Film	-	-	.68
(4)	Concrete	10	12.5	.80				total	23.9

APPENDIX- 07f | FOUNDATION TO WALL TRANSITIONS: Foundation Wall Sandwich Panel Study

Sandwich panel foundation wall (B)
(6" Conc. + 4" Insul. + 8" Conc.)

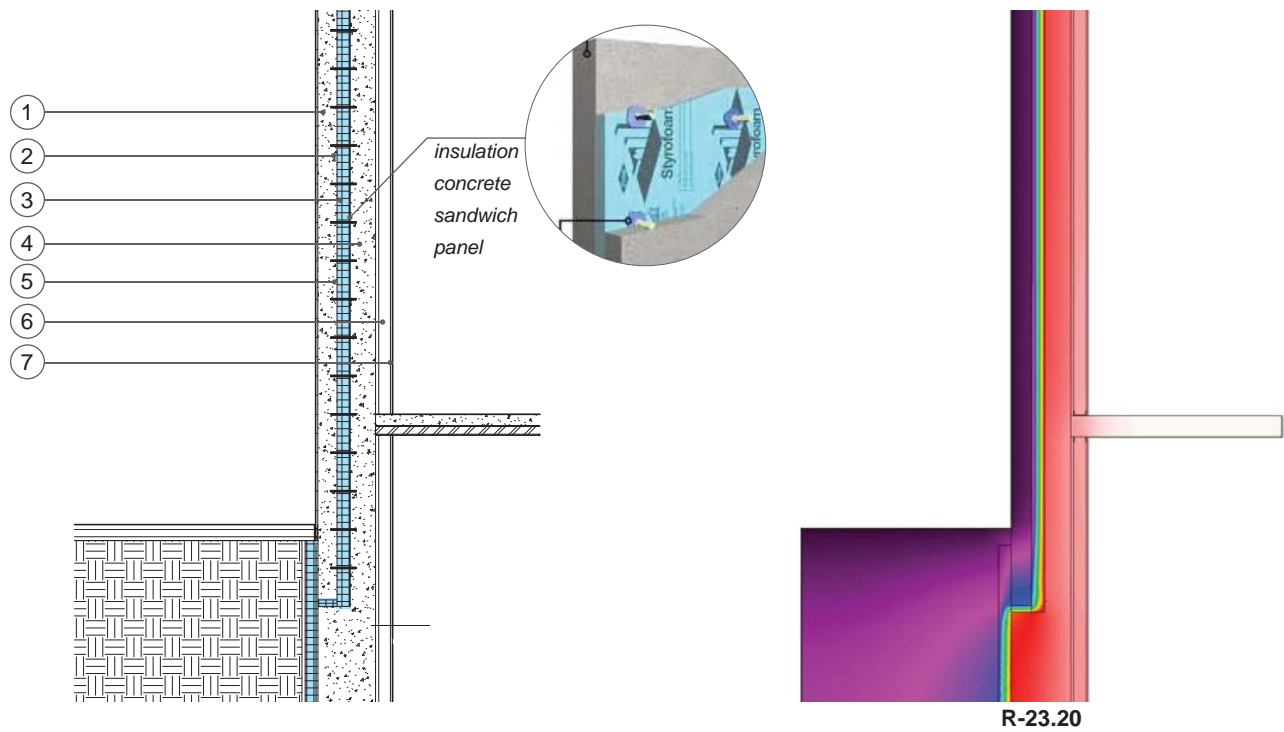

Calculated Baseline Clear Wall R-value									
	Material	Width in.	k Btu·in/h·ft ² ·°F	R-value h·ft ² ·°F/Btu		Material	Width in.	k Btu·in/h·ft ² ·°F	R-value h·ft ² ·°F/Btu
-	Exterior Air Film	-	-	0.17	(5)	Composite Ties	-	.25	-
(1)	Concrete	6	12.5	.48	(6)	Air Cavity	-	-	1.36
(2)	Rigid Insulation	4	.2	20	(7)	Gypsum Board	0.625	1.1	0.57
(3)	Air and Vapor Barrier	-	-	-	-	Interior Air Film	-	-	.68
(4)	Concrete	8	12.5	.64				total	23.9

APPENDIX- 08a | TRANSITIONS BETWEEN WALL SYSTEMS: Curtain Wall to Stone Veneer Base

Project Conditions

Location: Eastern Massachusetts
 Date of Thermal Image: 03/26/2013
 Exterior Air Temperature: 38.9 °F
 Interior Air Temperature: 68.7 °F
 Radiant Temperature: N/A °F
 Assumed Emissivity: 0.9

Summary of Thermal Performance

Calculated Baseline R-Value: 17.53 -
As-Built Condition
 Simulated (THERM) R-Value: 5.33 - 69 %

As-Built Condition

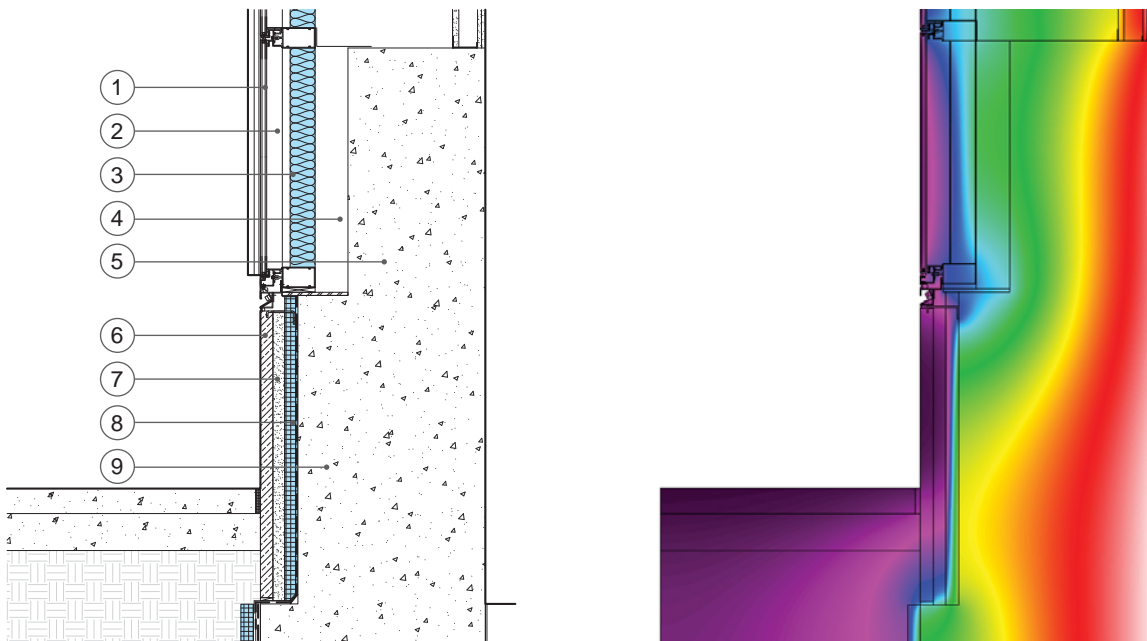

Calculated Baseline Clear Wall R-value (at Curtain Wall)					Calculated Baseline Clear Wall R-value (at Foundation)				
	Material	Width in.	k Btu-in/h-ft2·°F	R-value h-ft2·°F/Btu		Material	Width in.	k Btu-in/h-ft2·°F	R-value h-ft2·°F/Btu
-	Exterior Air Film	-	-	0.17	-	Exterior Air Film	-	-	0.17
①	Curtain Wall	1	-	2.65	⑥	Stone Veneer	2.00	30.00	0.07
②	Air Space			1.23	⑦	Grouted Cavity	2.00	6.70	0.30
③	Curtain Wall Insulation	4.00	0.29	13.74	⑧	Rigid Insulation	2.00	0.20	10.00
④	Air Cavity	-	-	1.36	⑨	Concrete	30.00	12.5	2.4
⑤	Concrete	20	12.5	1.6	-	Interior Air Film	-	-	0.68
-	Interior Air Film	-	-	0.68					
				total wall (CW)					total wall (F)
				21.43					13.62
									Composite wall value (.5*CW+.5*F)
									17.53



APPENDIX- 08b | TRANSITIONS BETWEEN WALL SYSTEMS: Stone Veneer to Curtain Wall

Project Conditions

Location: Central Pennsylvania
 Date of Thermal Image: 02/22/2013
 Exterior Air Temperature: 35.4 °F
 Interior Air Temperature: 72.9 °F
 Radiant Temperature: N/A °F
 Assumed Emissivity: 0.9

Summary of Thermal Performance

Calculated Baseline R-Value: 14.94 -
As-Built Condition
 Thermal Image R-Value: 12.35 - 83 %

As-Built Condition

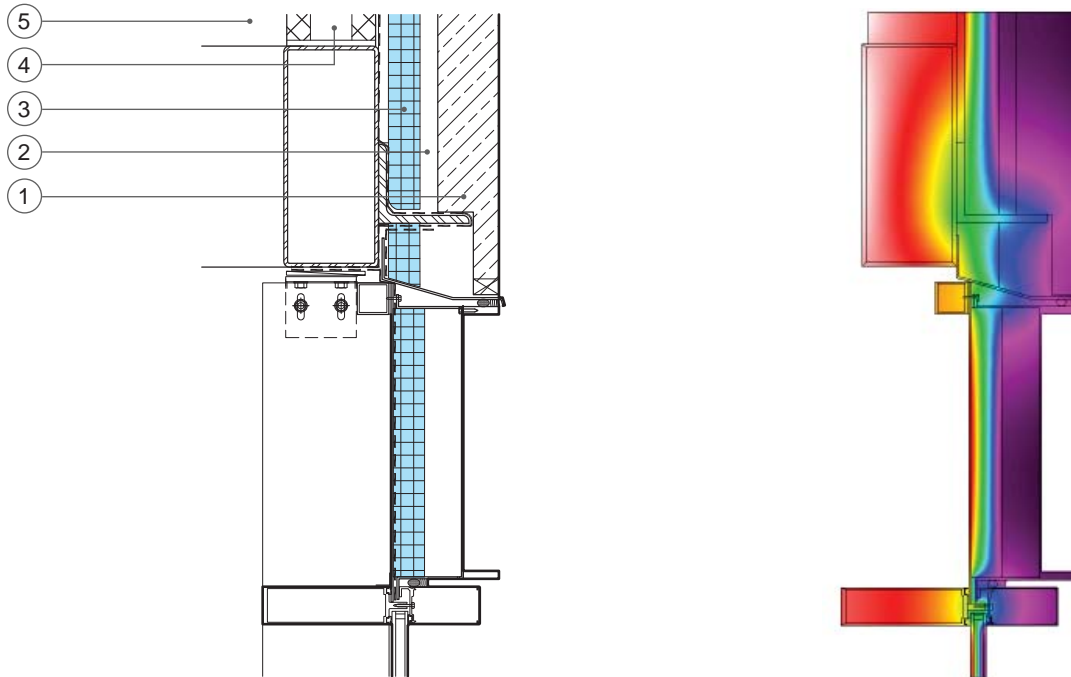

Calculated Baseline Clear Wall R-value									
	Material	Width in.	<i>k</i> Btu·in/h·ft ² ·°F	R-value h·ft ² ·°F/Btu		Material	Width in.	<i>k</i> Btu·in/h·ft ² ·°F	R-value h·ft ² ·°F/Btu
-	Exterior Air Film	-	-	0.17	(4)	CMU	5.63	8.00	0.70
(1)	Limestone Panel	3.00	30.00	0.10	(5)	Air Cavity	-	-	1.36
(2)	Air Cavity	-	-	1.36	(6)	Gypsum Board	0.63	1.10	0.57
(3)	Rigid Insulation	2.00	0.20	10.00	-	Interior Air Film	-	-	0.68
								total	14.94



APPENDIX- 09a | SOFFITS: Soffit at Rain Screen Wall

Project Conditions

Location: Eastern Massachusetts
 Date of Thermal Image: N/A
 Exterior Air Temperature: N/A
 Interior Air Temperature: N/A
 Radiant Temperature: N/A
 Assumed Emissivity: N/A

Summary of Thermal Performance

Calculated Baseline R-Value: 19.14 -
As-Built Condition
 Thermal Image R-Value: N/A -
 Simulated (THERM) R-Value: 17.2 - 10 %
Thermally Improved Condition
 Simulated (THERM) R-Value: 28.3 +48 %

As-Built Condition

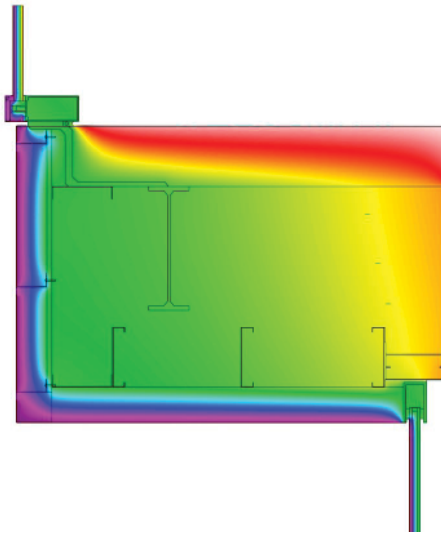
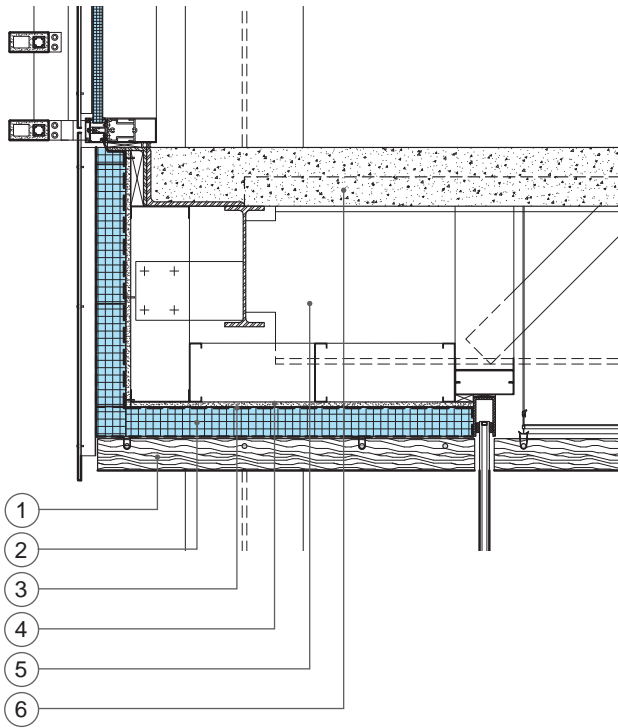

R-17.2

Calculated Baseline Soffit R-value										
	Material	Width in.	<i>k</i> Btu·in/h·ft ² ·°F	R-value h·ft ² ·°F/Btu		Material	Width in.	<i>k</i> Btu·in/h·ft ² ·°F	R-value h·ft ² ·°F/Btu	
①	Wood Panel	3.25	-	-	⑤	Air Cavity	20	-	1.36	
-	Exterior Air Film	-	-	0.68	⑥	Concrete Slab	6.0	7.0	0.85	
②	Rigid Insulation	3.00	.2	15	-	Interior Air Film	-	-	0.68	
③	Exterior Sheathing	0.625	1.1	0.57						
									total	19.14

APPENDIX- 09a | SOFFITS: Soffit at Rain Screen Wall



Digital Image

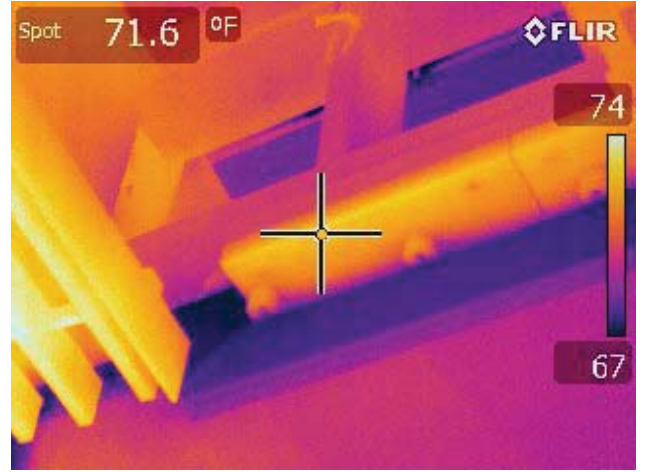

Infrared Image

Thermally Improved Condition

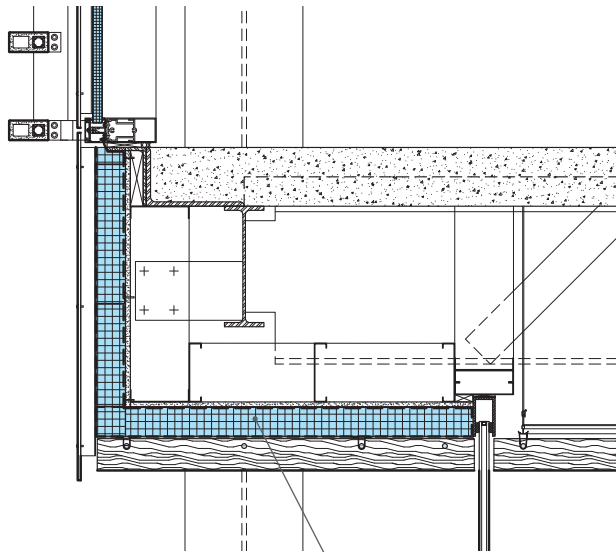

z-girts have been replaced with stainless steel bolts and plate out of the plane of insulation

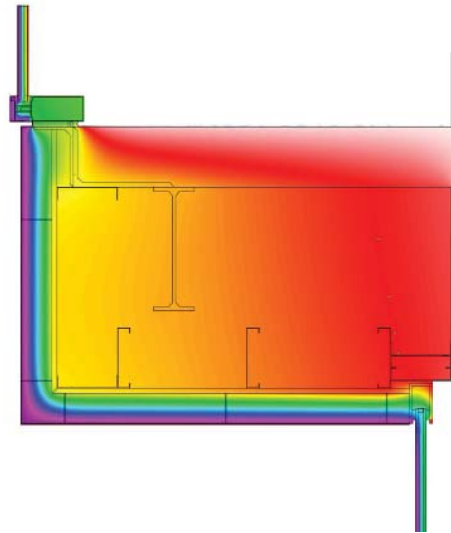

R-28.3
(+64.5%)

APPENDIX- 09b | SOFFITS: Soffit at Metal Panel Wall

Project Conditions

Location: Eastern Massachusetts
 Date of Thermal Image: 3/26/2013
 Exterior Air Temperature: 38.8
 Interior Air Temperature: 60.2
 Radiant Temperature: 62.8
 Assumed Emissivity: 0.9

Summary of Thermal Performance

Calculated Baseline R-Value: 1.84 -
As-Built Condition
 Thermal Image R-Value: 2.28 - 84 %
 Simulated (THERM) R-Value: 15.6 +12.7 %
Thermally Improved Condition
 Simulated (THERM) R-Value: N/A -

As-Built Condition

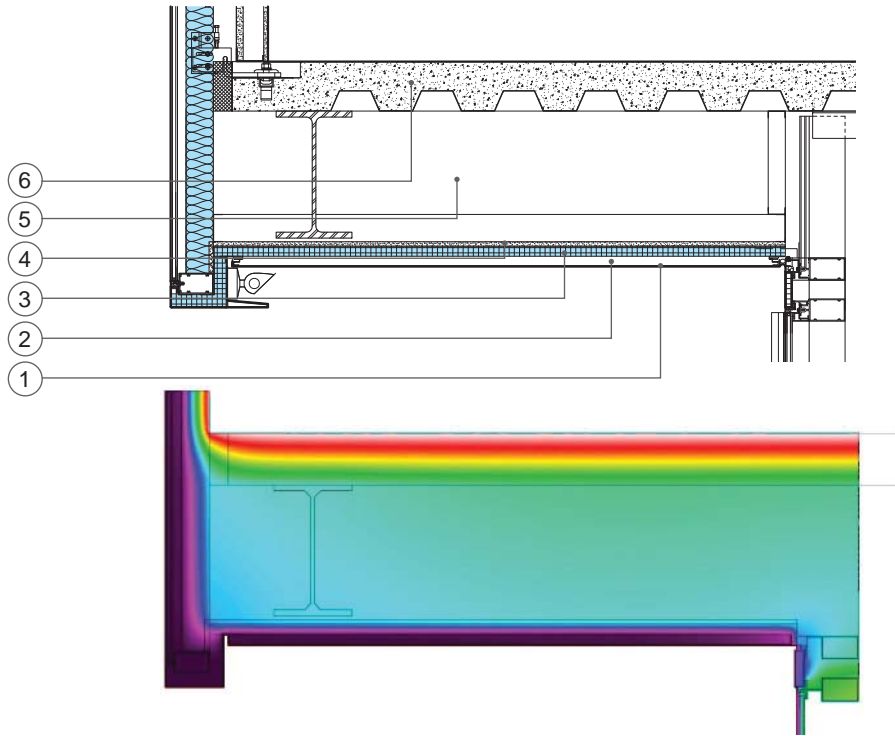

Calculated Baseline Clear Wall R-value										
	Material	Width in.	k Btu-in/h-ft2·°F	R-value h-ft2·°F/Btu		Material	Width in.	k Btu-in/h-ft2·°F	R-value h-ft2·°F/Btu	
-	Exterior Air Film	-	-	0.17	(5)	Air Cavity	19.125	-	1.36	
(1)	Composite Panel	-	-	0.06	(6)	Concrete Slab	6	7.0	0.85	
(2)	Air Cavity	-	-	1	-	Interior Air Film	-	-	0.68	
(3)	Rigid Insulation	2.00	0.20	10						
(4)	Exterior Sheathing	0.625	1.10	0.57						
									total	14.69

APPENDIX- 09b | SOFFITS: Soffit at Metal Panel Wall



Digital Image

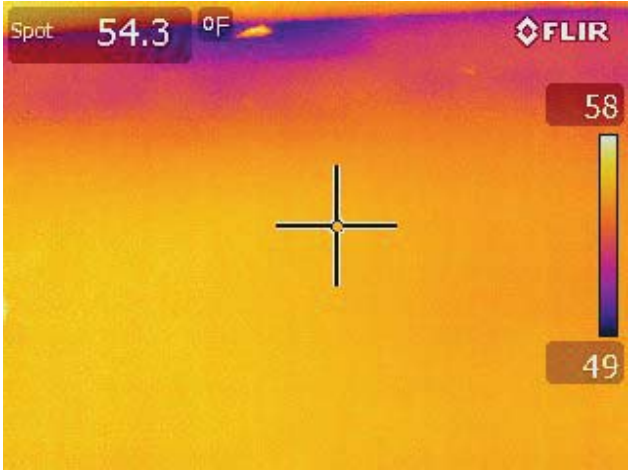

Infrared Image

APPENDIX- 09c | SOFFITS: Soffit at Stone Cladding

Project Conditions

Location: Eastern Pennsylvania
 Date of Thermal Image: N/A
 Exterior Air Temperature: N/A
 Interior Air Temperature: N/A
 Radiant Temperature: N/A
 Assumed Emissivity: N/A

Summary of Thermal Performance

Calculated Baseline R-Value: 15.34 -
As-Built Condition
 Thermal Image R-Value: N/A -
 Simulated (THERM) R-Value: 16.1 +5 %
Thermally Improved Condition
 Simulated (THERM) R-Value: 17.2 +12 %

As-Built Condition

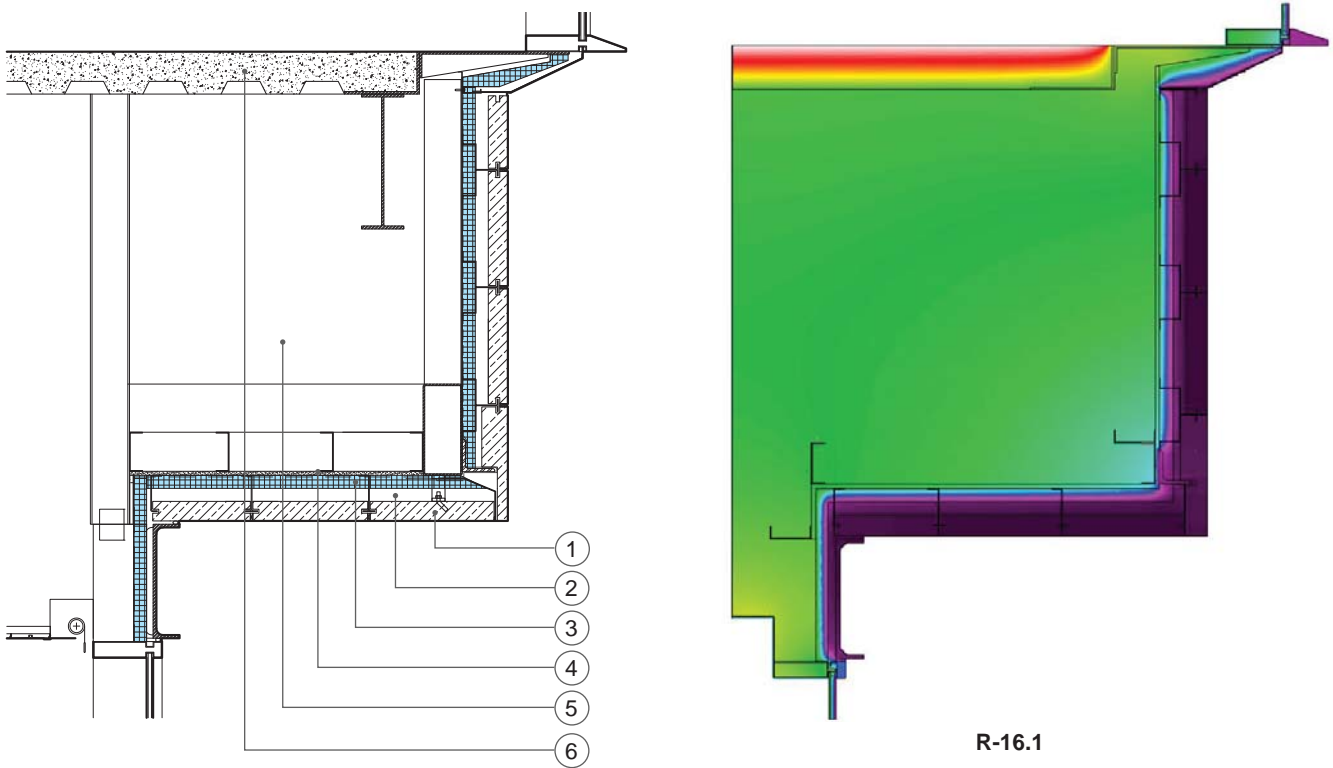

Calculated Baseline Clear Wall R-value									
	Material	Width in.	k Btu-in/h-ft ² ·°F	R-value h-ft ² ·°F/Btu		Material	Width in.	k Btu-in/h-ft ² ·°F	R-value h-ft ² ·°F/Btu
-	Exterior Air Film	-	-	0.17	(4)	Exterior Sheathing	0.625	1.1	0.57
(1)	Limestone Panel	3.00	4	0.75	(5)	Air Cavity	57	-	1.36
(2)	Air Cavity	2.00	-	1.36	(6)	Concrete	6	13.49	0.45
(3)	Rigid Insulation	2.00	0.20	10	-	Interior Air Film	-	-	0.68
								total	15.34

APPENDIX- 09c | SOFFITS: Soffit at Stone Cladding

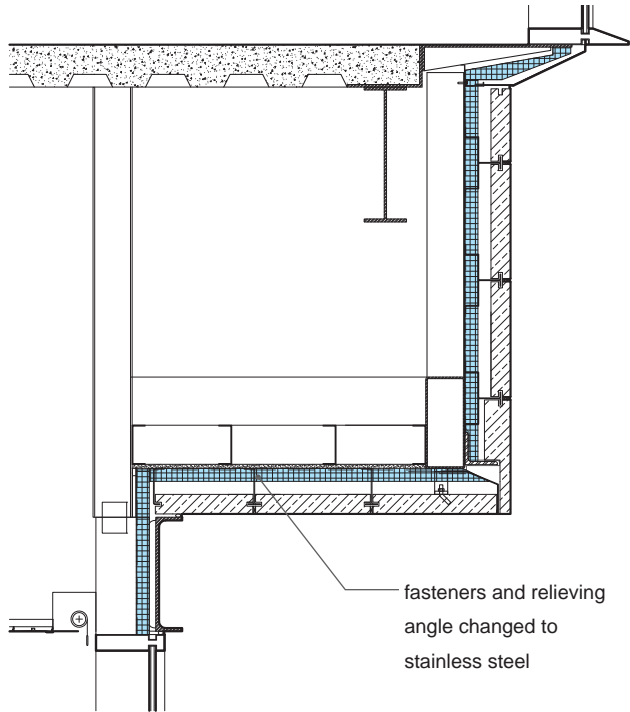

Thermally Improved Condition

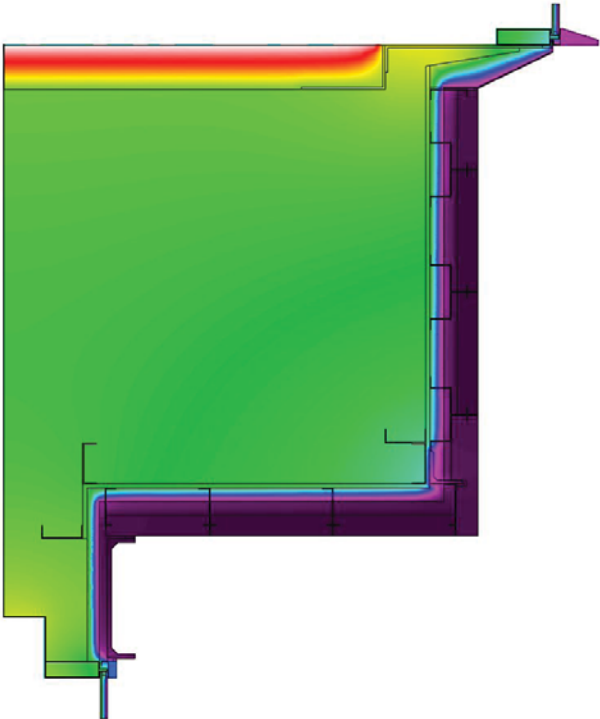

R-17.2
(+6.8%)

APPENDIX- 10a | ROOF TO WALL TRANSITIONS: Stud Back Up Wall with Insulation and Blocking

Project Conditions

Location: Massachusetts
 Date of Thermal Image: 2/21/2012
 Exterior Air Temperature: 37.7 °F
 Interior Air Temperature: 69.9 °F
 Radiant Temperature: 71.5 °F
 Assumed Emissivity: 0.9

Summary of Thermal Performance

Calculated Baseline R-Value: 13.86 -
As-Built Condition
 Thermal Image R-Value: 3.88 - 75 %
 Simulated (THERM) R-Value: 6.40 - 54 %
Thermally Improved Condition
 Simulated (THERM) R-Value: N/A N/A

As-Built Condition

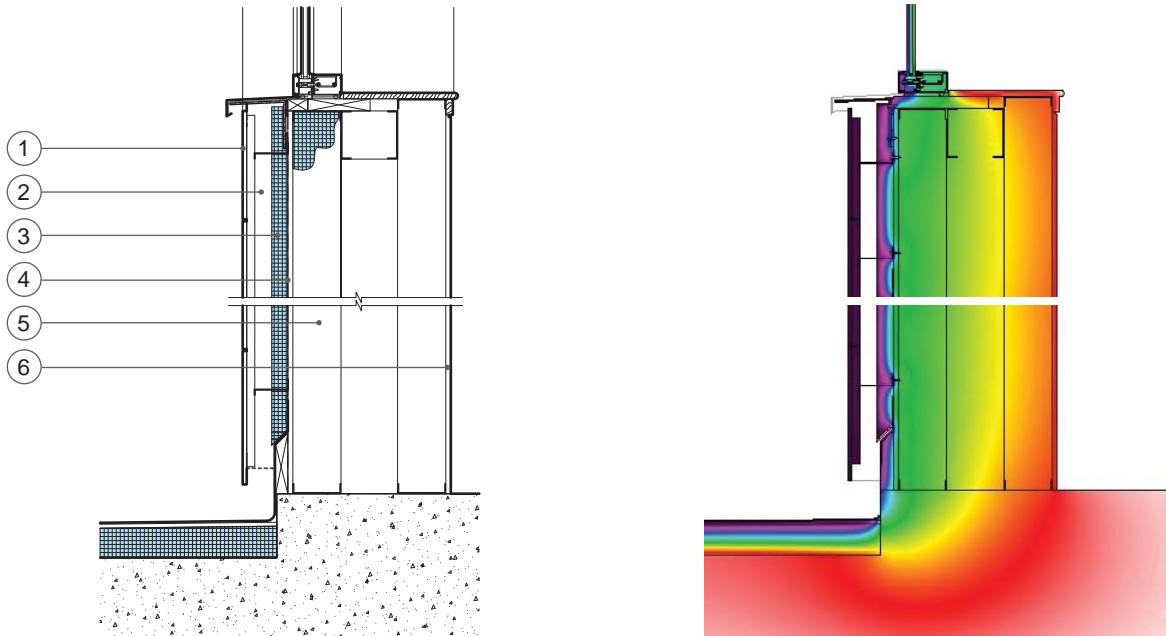

Calculated Baseline Clear Wall R-value									
	Material	Width in.	k Btu-in/h-ft2·°F	R-value h-ft2·°F/Btu		Material	Width in.	k Btu-in/h-ft2·°F	R-value h-ft2·°F/Btu
①	FRC Panel	-	-	-	④	Gypsum Board	0.625	1.10	0.57
②	Air Space	-	-	-	⑤	Air Cavity	20	-	1.36
-	Exterior Air Film	-	-	0.68	⑥	Gypsum Board	0.625	1.10	0.57
③	Rigid Insulation	2.00	0.20	10.00	-	Interior Air Film	-	-	0.68
								total	13.86

APPENDIX- 10a | ROOF TO WALL TRANSITIONS: Stud Back Up Wall with Insulation and Blocking



Digital Image

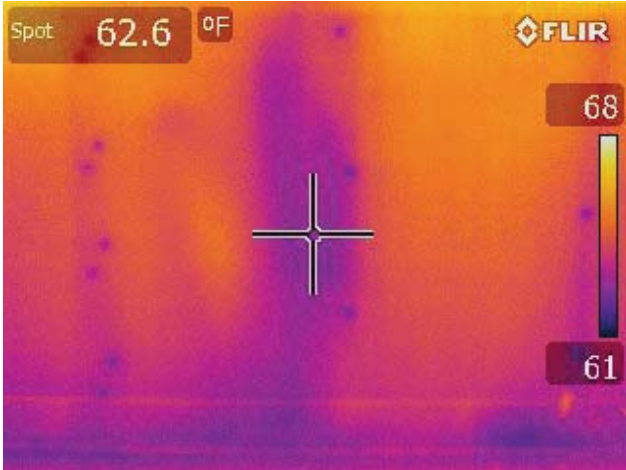

Infrared Image

APPENDIX- 10b | ROOF TO WALL TRANSITIONS: Stud Back Up Wall with Continuous Insulation

Project Conditions

Location: Massachusetts
 Date of Thermal Image: 2/9/2012
 Exterior Air Temperature: 37.7 °F
 Interior Air Temperature: 71.6 °F
 Radiant Temperature: 72.8 °F
 Assumed Emissivity: 0.9

Summary of Thermal Performance

Calculated Baseline R-Value: 16.74 -
As-Built Condition
 Thermal Image R-Value: 8.2 - 49 %
 Simulated (THERM) R-Value: 14 - 14 %
Thermally Improved Condition
 Simulated (THERM) R-Value: N/A -

As-Built Condition

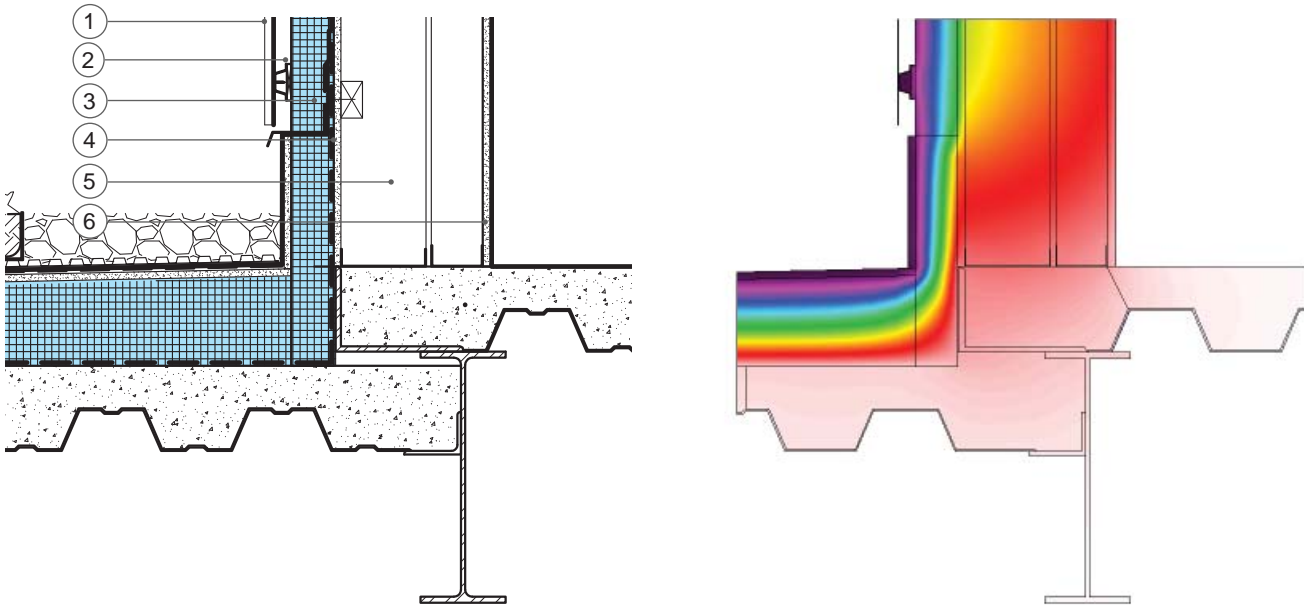

Calculated Baseline Clear Wall R-value									
	Material	Width in.	k Btu-in/h-ft ² ·°F	R-value h-ft ² ·°F/Btu		Material	Width in.	k Btu-in/h-ft ² ·°F	R-value h-ft ² ·°F/Btu
①	Corrugated Metal	-	-	-	⑤	Air Cavity	10	-	1.36
②	Air Space	-	-	-	⑥	Gypsum Board	0.625	1.1	0.57
-	Exterior Air Film	-	-	0.68	-	Interior Air Film	-	-	0.68
③	Mineral Wool	3.00	0.23	13					
④	Exterior Sheathing	0.50	1.1	0.45					
								total	16.74

APPENDIX- 10b | ROOF TO WALL TRANSITIONS: Stud Back Up Wall with Continuous Insulation



Digital Image

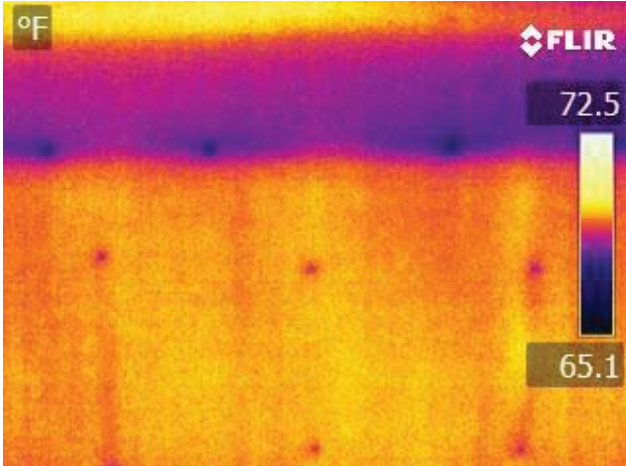

Infrared Image

APPENDIX- 10c | ROOF TO WALL TRANSITIONS: CMU Back Up with Continuous Insulation

Project Conditions

Location: Western Massachu-
 Date of Thermal Image: setts
 2/27/2012
 Exterior Air Temperature: 49.6 °F
 Interior Air Temperature: 69.9 °F
 Radiant Temperature: 70.6 °F
 Assumed Emissivity: 0.9

Summary of Thermal Performance

Calculated Baseline R-Value: 15.42 -
As-Built Condition
 Thermal Image R-Value: 5.5 - 64 %
 Simulated (THERM) R-Value: 5.5 - 64 %
Thermally Improved Condition
 Simulated (THERM) R-Value: N/A N/A

As-Built Condition

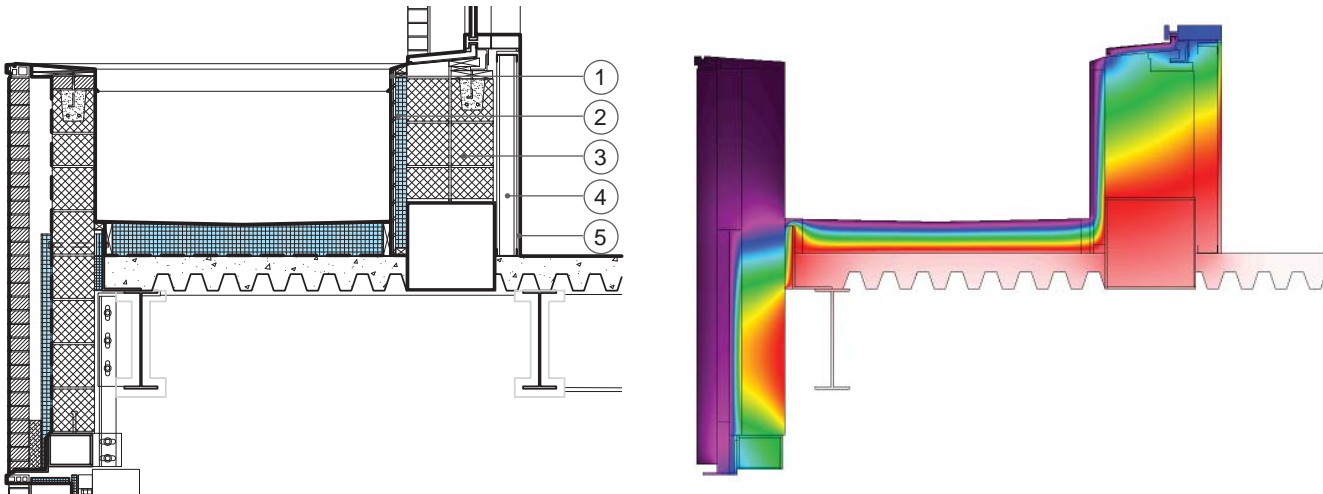

Calculated Baseline Clear Wall R-value									
	Material	Width in.	<i>k</i> Btu-in/h-ft2-°F	R-value h-ft2-°F/Btu		Material	Width in.	<i>k</i> Btu-in/h-ft2-°F	R-value h-ft2-°F/Btu
-	Exterior Air Film	-	-	0.17	(5)	Gypsum Board	0.625	1.1	0.57
(1)	Exterior Sheathing	0.75	1.18	0.64	-	Interior Air Film	-	-	0.68
(2)	Extruded Polystyrene	2.00	0.20	10					
(3)	Concrete Block	16	8	2					
(4)	Air Cavity	3.625	-	1.36					
								total	15.42

APPENDIX- 10c | ROOF TO WALL TRANSITIONS: CMU Back Up with Continuous Insulation



Digital Image

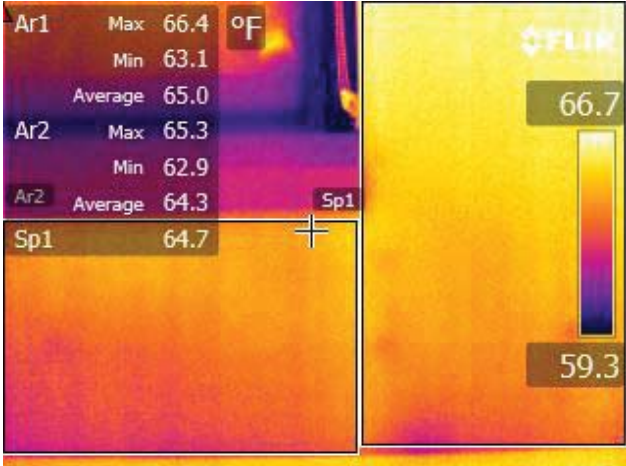

Infrared Image

APPENDIX- 11a | PARAPETS: Parapet Height Study

Parapet Height Study

This study works with limited variables to see how the parapet height can have a negative impact on the thermal envelope.

Summary of Thermal Performance

Simulated Baseline R-Value: (insulating beneath the parapet)	15.33	-
Simulated 1'-3" tall parapet R-Value:	13.42	- 12.5 %
Simulated 2'-6" tall parapet R-Value:	12.25	- 20.1 %
Simulated 5'-0" tall parapet R-Value:	11.27	- 26.5 %

As-Built Condition

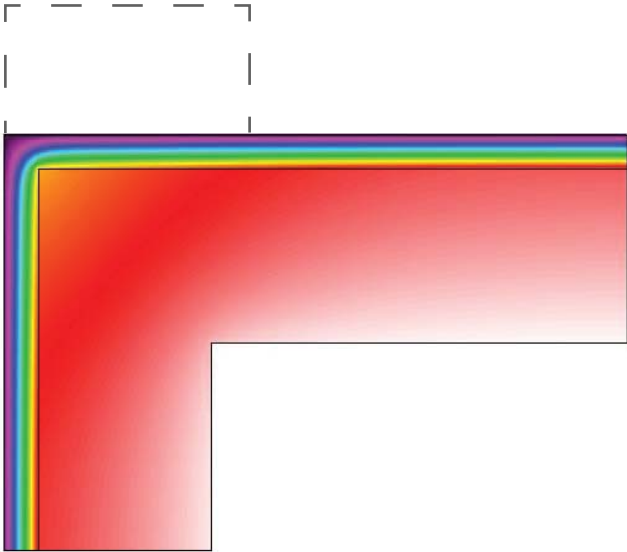

R-15.33
Insulating beneath parapet

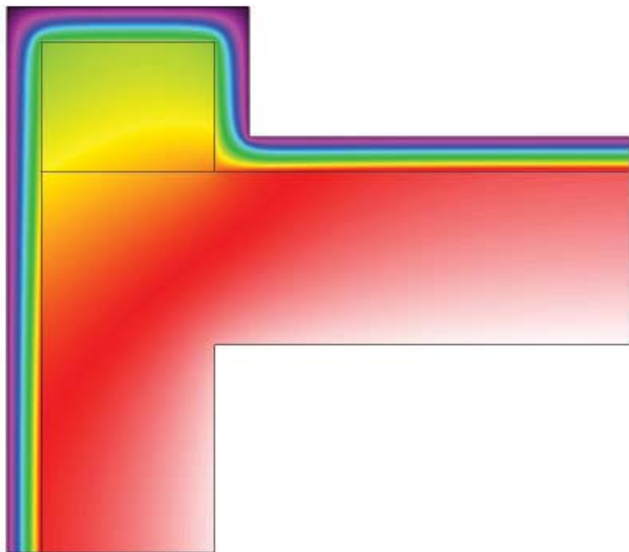

R-13.42
Insulating around 1'-3" tall parapet

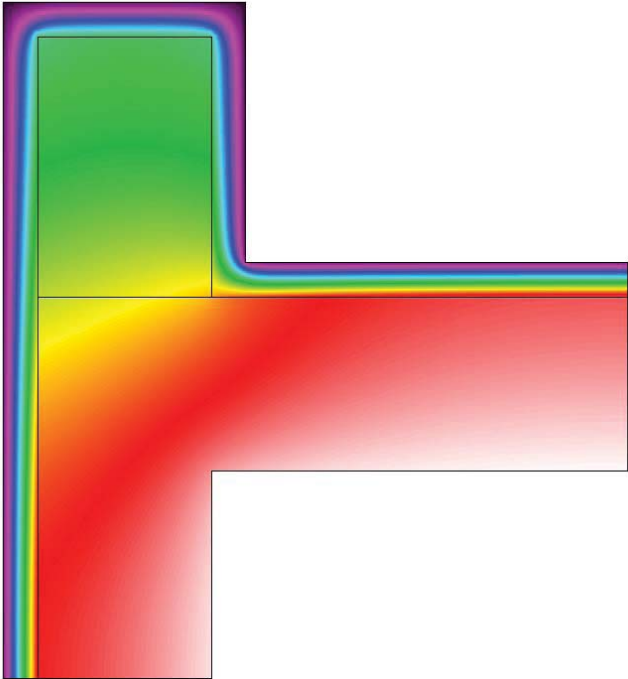

R-12.25
Insulating around 2'-6" tall parapet

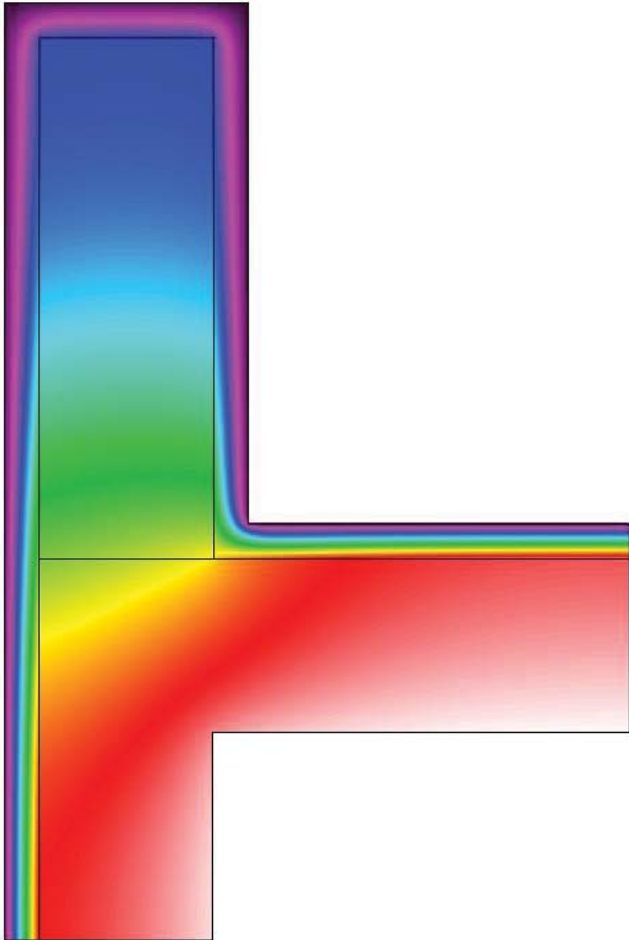

R-11.27
Insulating around 5'-0" tall parapet

APPENDIX- 11b | PARAPETS: Insulated Metal Panel Stud Wall

Project Conditions

Location:	New York State
Date of Thermal Image:	N/A
Exterior Air Temperature:	N/A
Interior Air Temperature:	N/A
Radiant Temperature:	N/A
Assumed Emissivity:	N/A

Summary of Thermal Performance

Calculated Baseline R-Value:	22.34	-
As-Built Condition		
Thermal Image R-Value:	N/A	-
Simulated (THERM) R-Value:	8.57	-61.6 %
Thermally Improved Condition		
Simulated (THERM) R-Value:	10.65	- 52.3 %

As-Built Condition

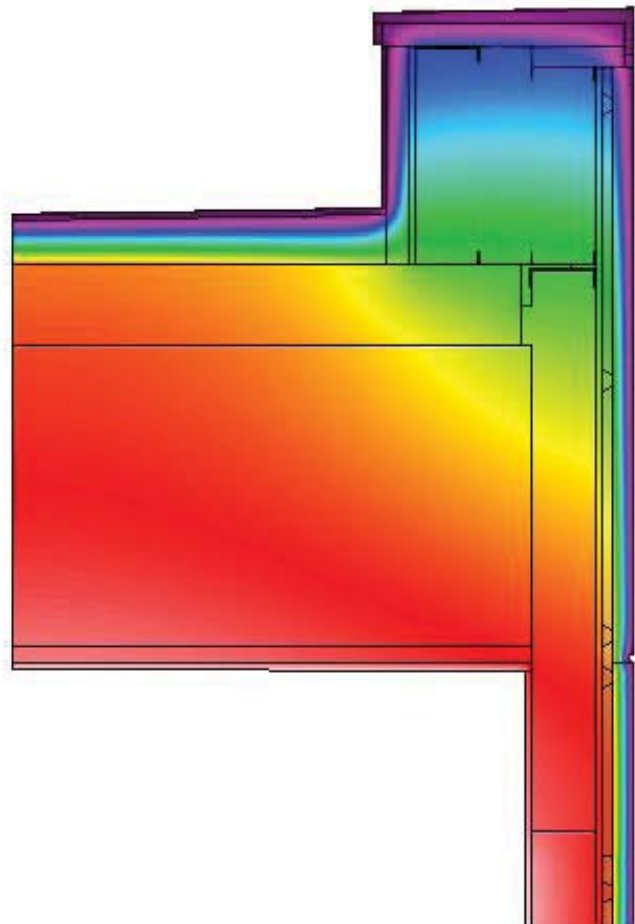
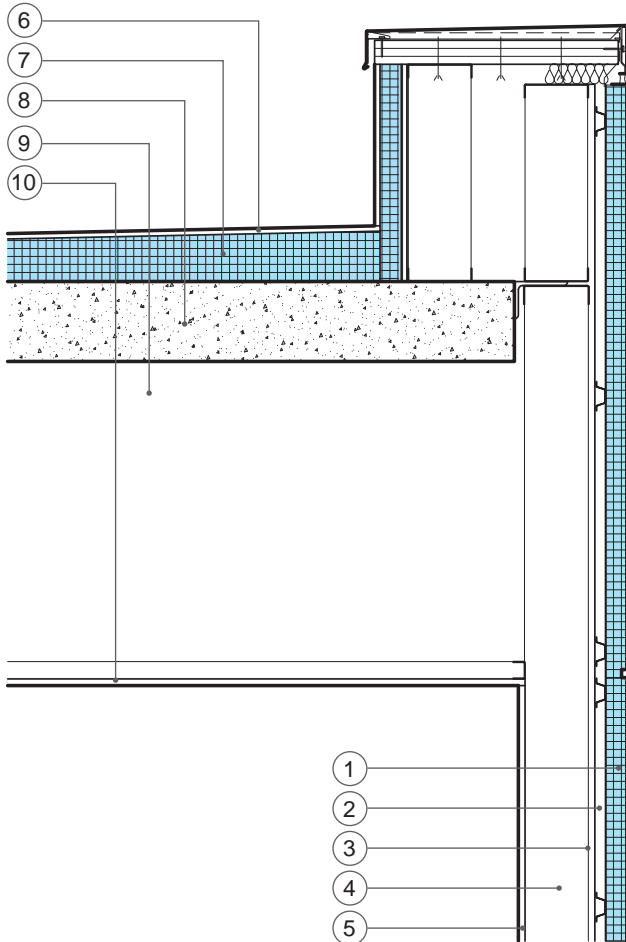

R-8.57

APPENDIX- 11b | PARAPETS: Insulated Metal Panel Stud Wall

Calculated Wall Baseline R-value					Calculated Roof Baseline R-value				
	Material	Width in.	k Btu-in/h-ft ² ·°F	R-value h-ft ² ·°F/Btu		Material	Width in.	k Btu-in/h-ft ² ·°F	R-value h-ft ² ·°F/Btu
-	Exterior Air Film	-	-	0.17	-	Exterior Air Film	-	-	0.17
①	Insulated Metal Panel (XPS)	2	0.20	10	⑥	Gypsum Board	0.625	1.10	0.57
②	Air Cavity	1	-	1	⑦	Extruded Polystyrene	4.5	0.20	22.5
③	Gypsum Board	0.625	1.10	0.57	⑧	Concrete Slab	7.5	13.5	0.56
④	Interior Air Film	6	-	1.36	⑨	Air Cavity	30	-	1.36
⑤	Gypsum Board	0.625	1.10	0.57	⑩	Gypsum Board	0.625	1.10	0.57
-	Interior Air Film	-	-	0.68	-	Interior Air Film	-	-	0.61
				total wall	14.35				
						total roof			
						26.34			
						Sum of R-values (1/3 wall total+ 2/3 roof total)			
						22.34			

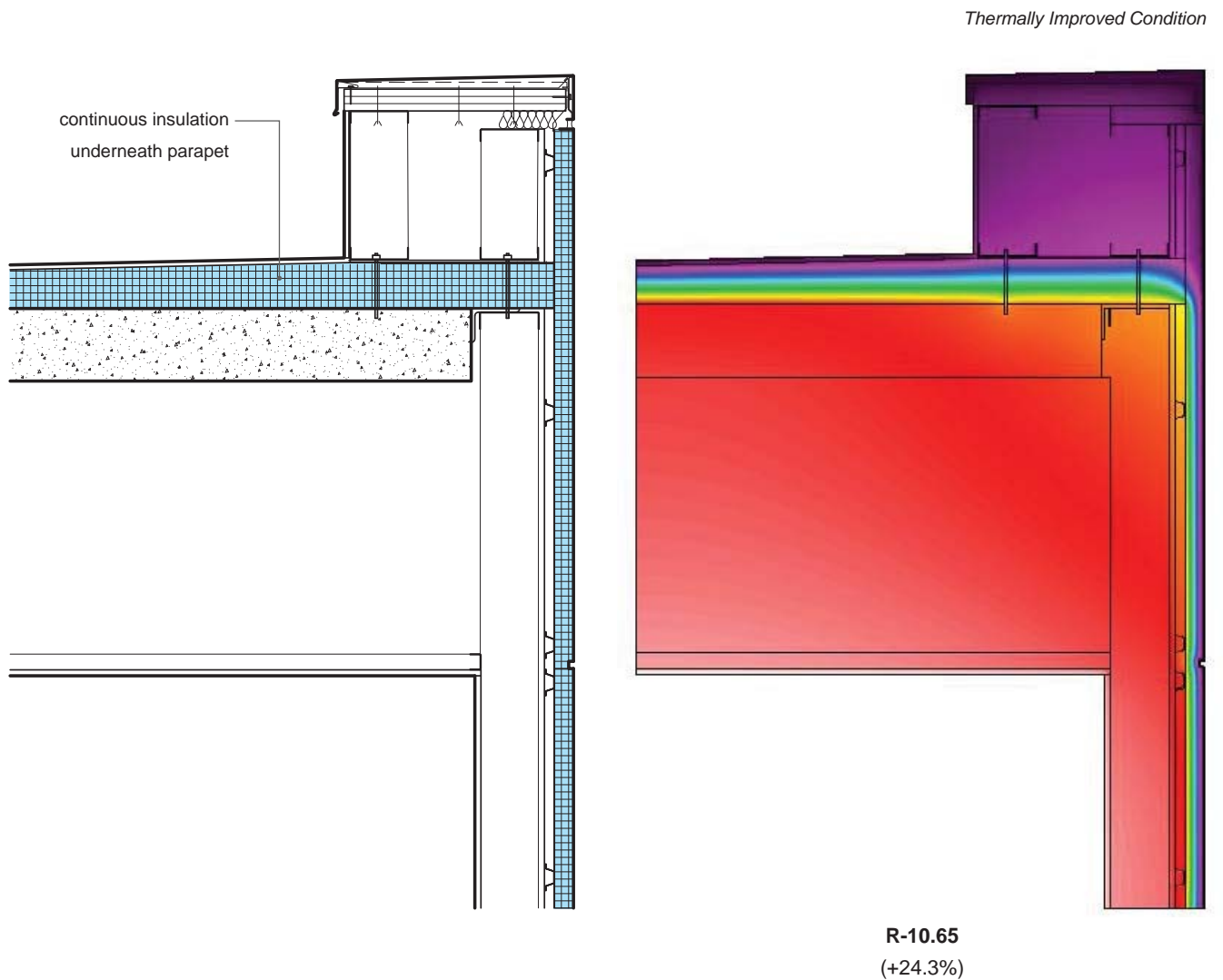

APPENDIX- 11c | PARAPETS: Concrete Wall

Project Conditions

Location:	Eastern Massachusetts
Date of Thermal Image:	N/A
Exterior Air Temperature:	N/A
Interior Air Temperature:	N/A
Radiant Temperature:	N/A
Assumed Emissivity:	N/A

Summary of Thermal Performance

Calculated Baseline R-Value:	23.15	-
As-Built Condition		
Thermal Image R-Value:	N/A	-
Simulated (THERM) R-Value:	11.61	- 49.8 %
Thermally Improved Condition		
Simulated (THERM) R-Value:	14.18	- 38 %

As-Built Condition

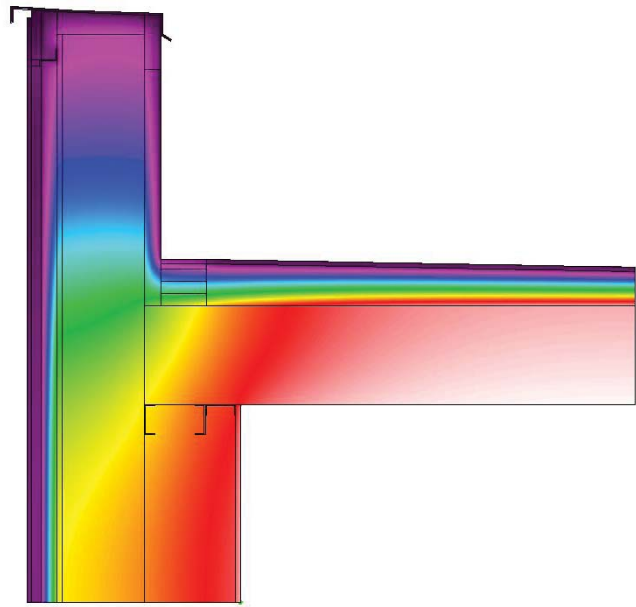
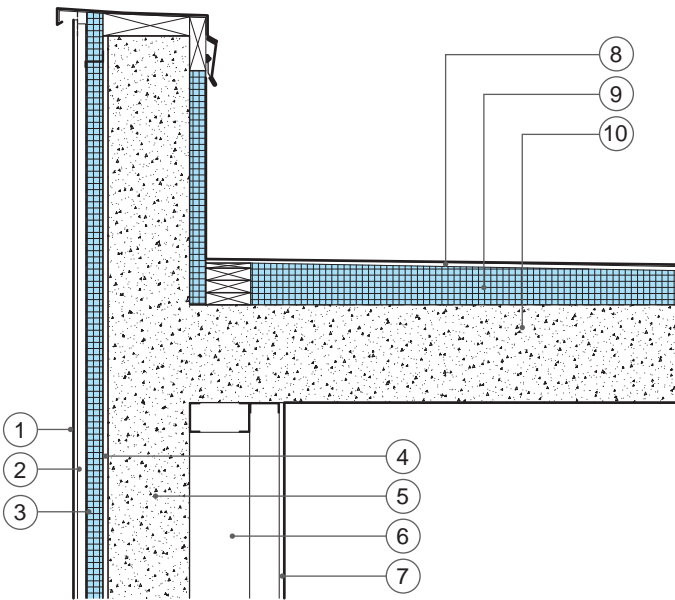

R-11.61

APPENDIX- 11c | PARAPETS: Concrete Wall

Calculated Wall Baseline R-value					Calculated Roof Baseline R-value					
	Material	Width in.	k Btu-in/h-ft ² ·°F	R-value h-ft ² ·°F/Btu		Material	Width in.	k Btu-in/h-ft ² ·°F	R-value h-ft ² ·°F/Btu	
①	Fiber Reinforced Cement Panel	.5	-	N/A	-	Exterior Air Film	-	-	0.68	
②	Air Cavity (Ventilated)	1	-	N/A	⑧	Substrate Board	0.625	1.10	0.57	
-	Exterior Air Film	-	-	0.17	⑨	Polyisocyanurate Board Insulation	4	-	23.6	
③	Extruded Polystyrene (XPS)	2	0.20	10	⑩	Concrete Slab	7.5	7.0	1.07	
④	Gypsum Board	0.625	1.10	0.57	-	Interior Air Film	-	-	0.68	
⑤	Concrete	10	13.5	0.74						
⑥	Air Cavity	11	-	1.37						
⑦	Gypsum Board	0.625	1.10	0.57						
-	Interior Air Film	-	-	0.68						
				total wall					total roof	26.6
									Comparable Sum of R-values (1/3 wall total+ 2/3 roof total)	23.15

Thermally Improved Condition

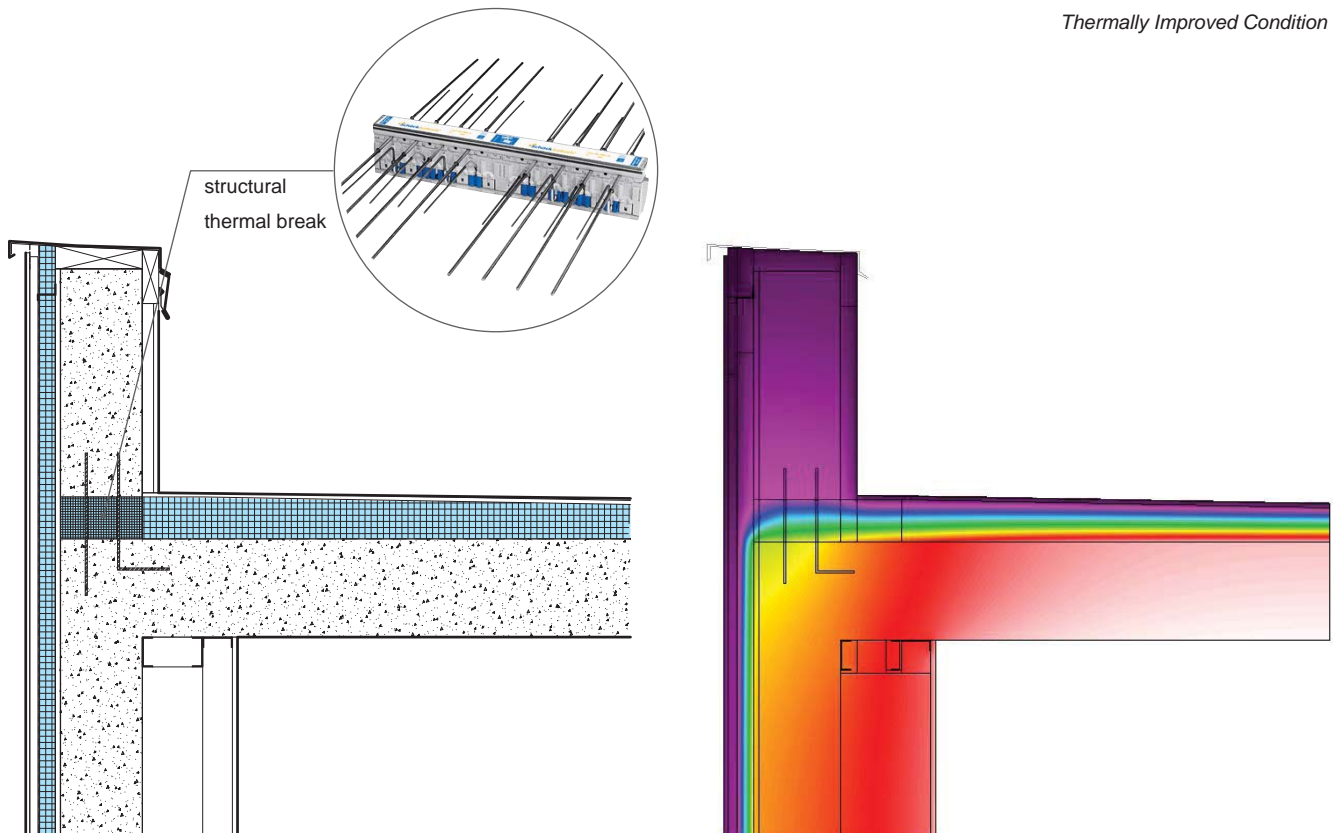

R-14.18
(+22%)

APPENDIX- 11d | PARAPETS: Masonry Cavity Wall

Project Conditions

Location:	Central Massachusetts
Date of Thermal Image:	N/A
Exterior Air Temperature:	N/A
Interior Air Temperature:	N/A
Radiant Temperature:	N/A
Assumed Emissivity:	N/A

Summary of Thermal Performance

Calculated Baseline R-Value:	26.1	-
As-Built Condition		
Thermal Image R-Value:	N/A	-
Simulated (THERM) R-Value:	7.58	- 70.9 %
Thermally Improved Condition		
Simulated (THERM) R-Value:	12.51	- 52 %

As-Built Condition

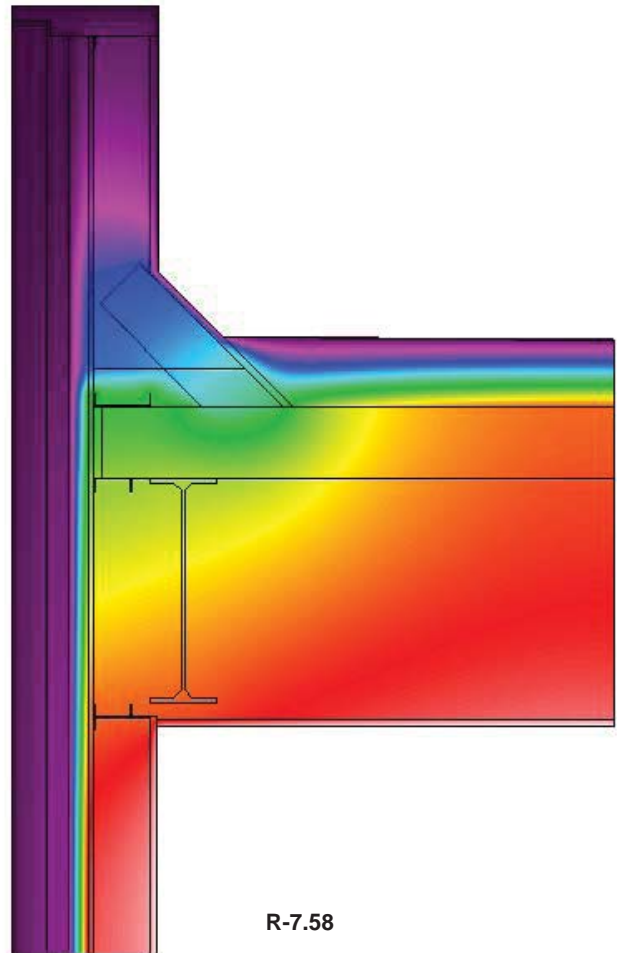
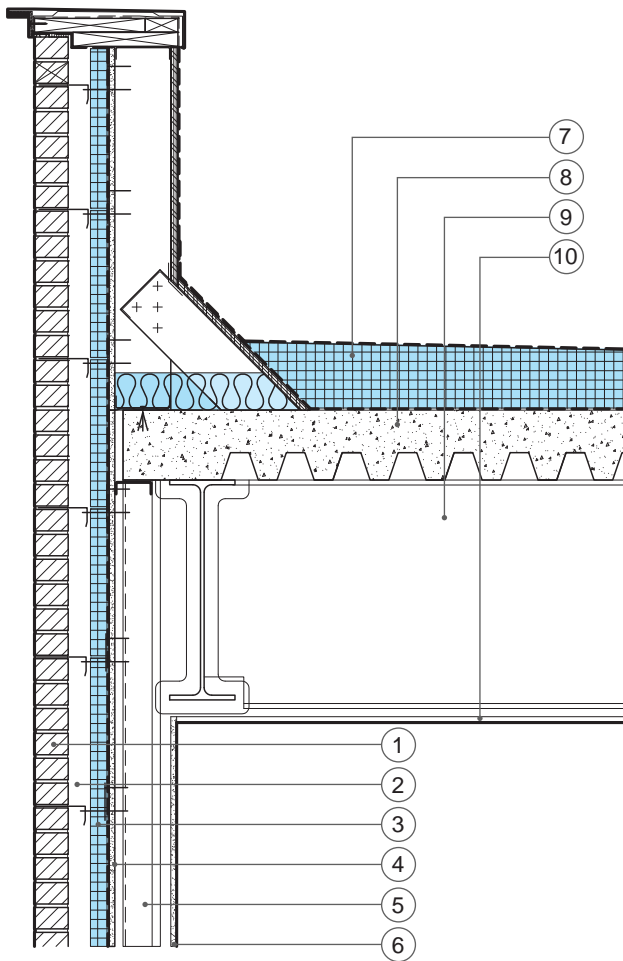

APPENDIX- 11d | PARAPETS: Masonry Cavity Wall

Calculated Wall Baseline R-value					Calculated Roof Baseline R-value						
	Material	Width in.	k Btu-in/h-ft ² ·°F	R-value h-ft ² ·°F/Btu		Material	Width in.	k Btu-in/h-ft ² ·°F	R-value h-ft ² ·°F/Btu		
-	Exterior Air Film	-	-	0.17	-	Exterior Air Film	-	-	0.17		
①	Brick Masonry	3.625	5.50	0.66	⑦	Polyisocyanurate Board Insulation	4.5	-	26.8		
②	Air Cavity	11	-	1.00							
③	Extruded Polystyrene (XPS)	2	0.20	10	⑧	Concrete Slab	7.625	7.0	1.09		
④	Gypsum Board	0.625	1.10	0.57	⑨	Air Cavity	25	-	1.36		
⑤	Air Cavity	6	-	1.36	⑩	Gypsum Board	0.625	1.10	0.57		
⑥	Gypsum Board	0.625	1.10	0.57							
-	Interior Air Film	-	-	0.68	-	Interior Air Film	-	-	0.68		
				total wall	15.90					total roof	31.2
Comparable Sum of R-values (1/3 wall total+ 2/3 roof total)										26.1	

Thermally Improved Condition

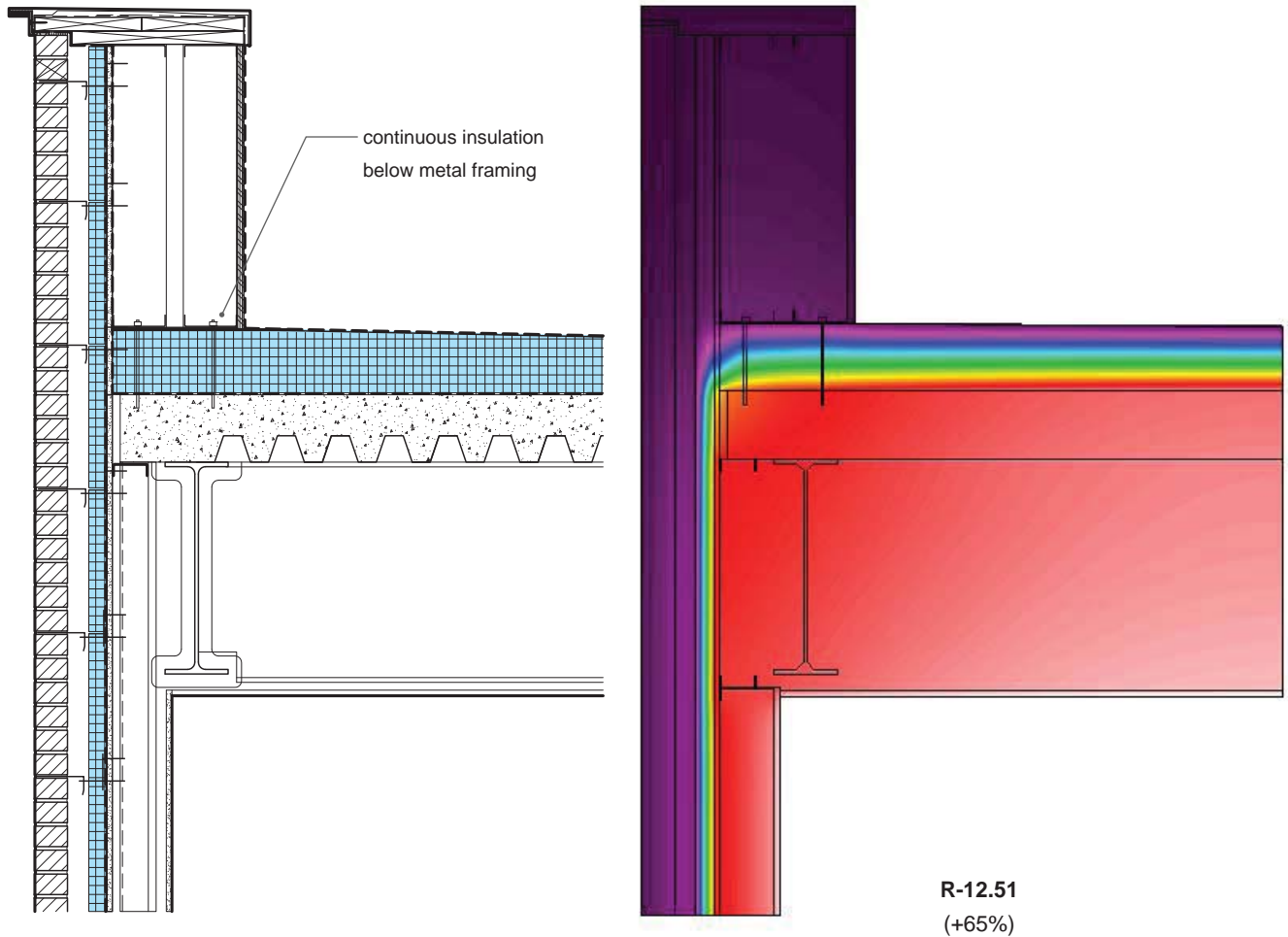

APPENDIX- 12a | ROOF PENETRATIONS: Roof Davits

Project Conditions

Location: Eastern Massachusetts
 Date of Thermal Image: 01/23/1013
 Exterior Air Temperature: 11.4 °F
 Interior Air Temperature: 59.7 °F
 Radiant Temperature: 59.4 °F
 Assumed Emissivity: 0.9

Summary of Thermal Performance

Calculated Baseline R-Value: 17.75 -
As-Built Condition
 Thermal Image R-Value: 5.76 - 67 %
 Simulated (THERM) R-Value: 10.07 - 43 %
Thermally Improved Condition
 Simulated (THERM) R-Value: N/A N/A

As-Built Condition

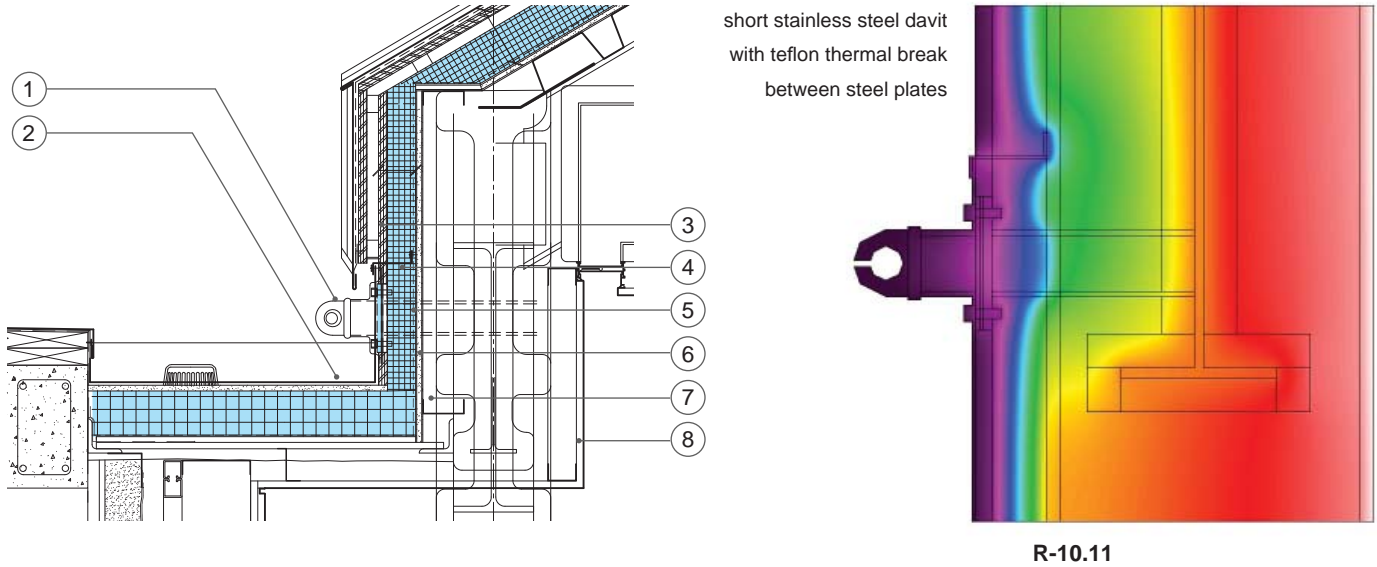

Calculated Baseline Clear Wall R-value									
	Material	Width in.	k Btu-in/h-ft2-°F	R-value h-ft2-°F/Btu		Material	Width in.	k Btu-in/h-ft2-°F	R-value h-ft2-°F/Btu
①	Thermally Broken Davit (24'-0" o.c.)	-	-	-	⑤	Air and Vapor Barrier	-	-	-
②	Roof Membrane	-	-	-	⑥	Gypsum Board	-	-	0.57
-	Exterior Air Film	-	-	0.17	⑦	Air Cavity	-	-	1.36
③	Exterior Sheathing	-	-	-	⑧	Gypsum Board	-	-	0.57
④	Polyiso Insulation	2.5	-	14.4	-	Interior Air Film	-	-	0.68
								total	17.75

APPENDIX- 12a | ROOF PENETRATIONS: Roof Davits



Digital Image

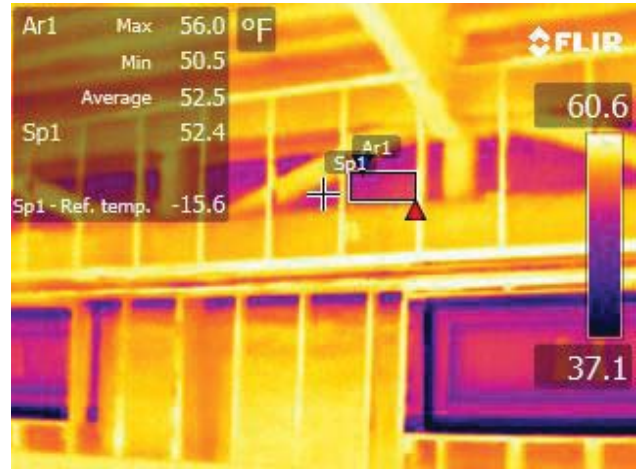

Infrared Image

Additional Davit Studies

base condition: galvanized steel davit directly attached to structure

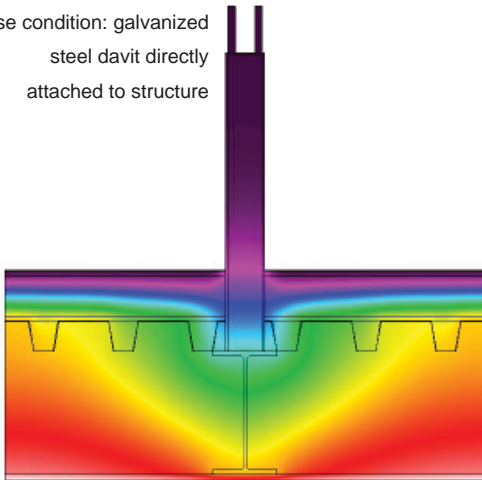

BASE MODEL

davit attached through a concrete slab with thermal break

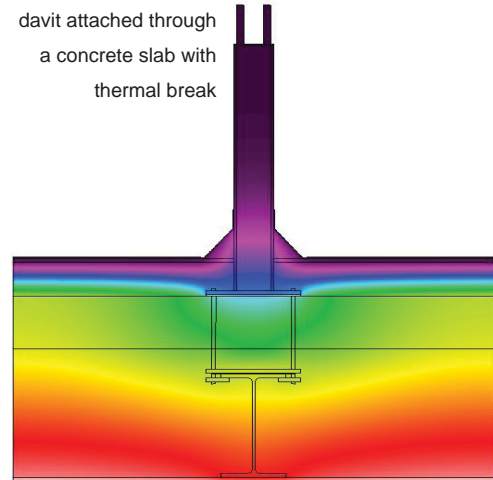

+ 23.5%

insulation added up to top of davit

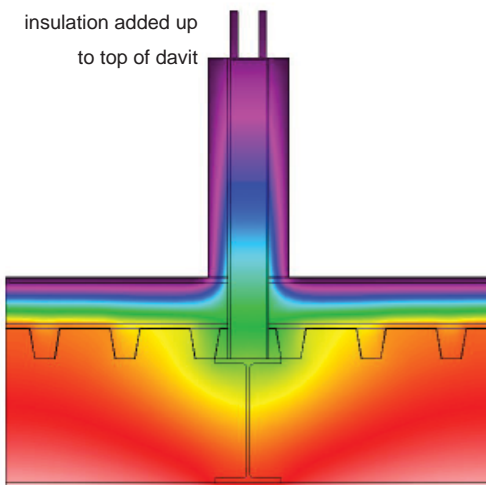

+ 30.9%

insulation added around exterior of a shorter davit

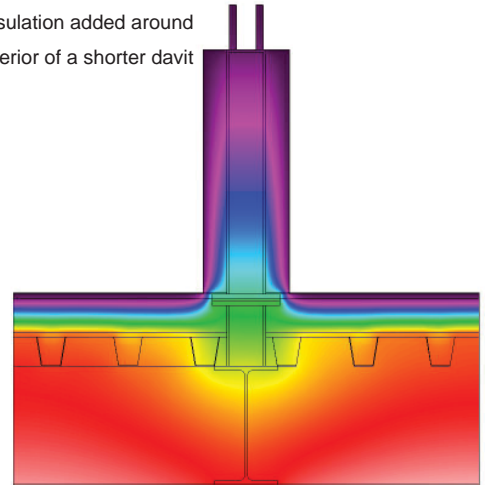

+ 53.9%

APPENDIX- 12b | ROOF PENETRATIONS: Hand Rail

Project Conditions

Location: Pennsylvania
 Date of Thermal Image: N/A
 Exterior Air Temperature: N/A
 Interior Air Temperature: N/A
 Radiant Temperature: N/A
 Assumed Emissivity: N/A

Summary of Thermal Performance

Calculated Baseline R-Value: 24.02 -
As-Built Condition
 Thermal Image R-Value: - -
 Simulated (THERM) R-Value: 4.75 -80 %
Thermally Improved Condition
 Simulated (THERM) R-Value: 7.75 - 67.7 %

As-Built Condition

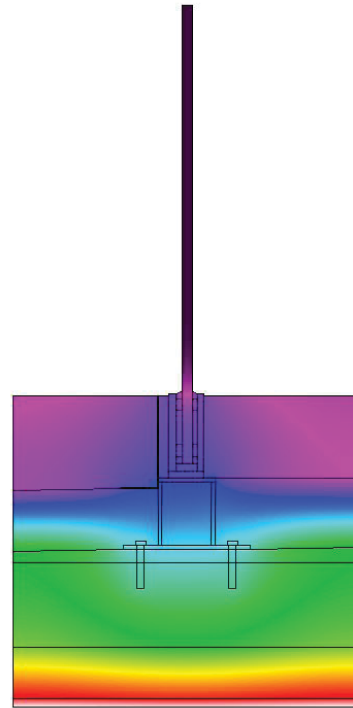
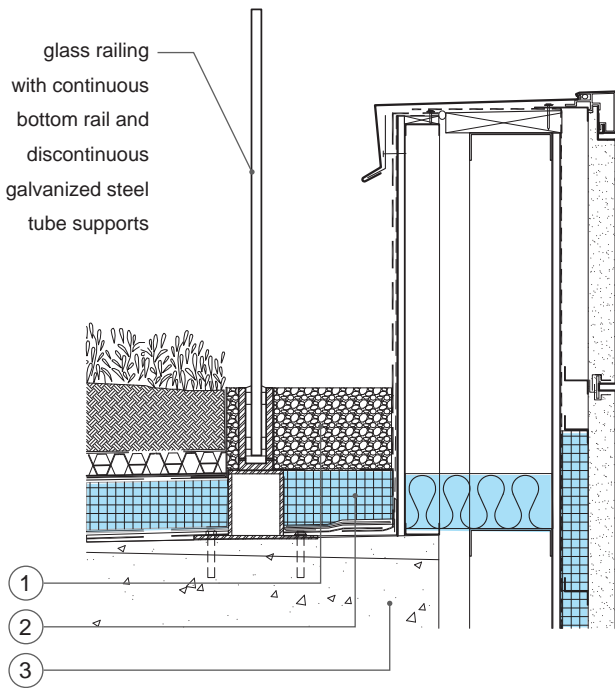

R-4.75

Calculated Baseline Clear Wall R-value									
	Material	Width in.	k Btu-in/h-ft ² ·°F	R-value h-ft ² ·°F/Btu		Material	Width in.	k Btu-in/h-ft ² ·°F	R-value h-ft ² ·°F/Btu
					③	Concrete	6.5	13.5	0.74
-	Exterior Air Film	-	-	0.17	-	Air Cavity	-	-	1.36
①	Gravel	6.00	12.00	0.50	-	Gypsum Board	0.63	1.10	0.57
②	XPS	4	0.20	20	-	Interior Air Film	-	-	0.68
								total	24.02

APPENDIX- 12b | ROOF PENETRATIONS: Hand Rail

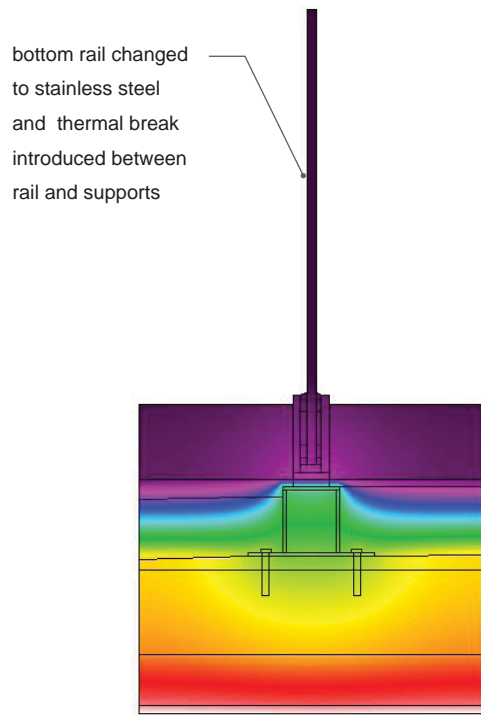

R-7.3
(+ 53.6%)

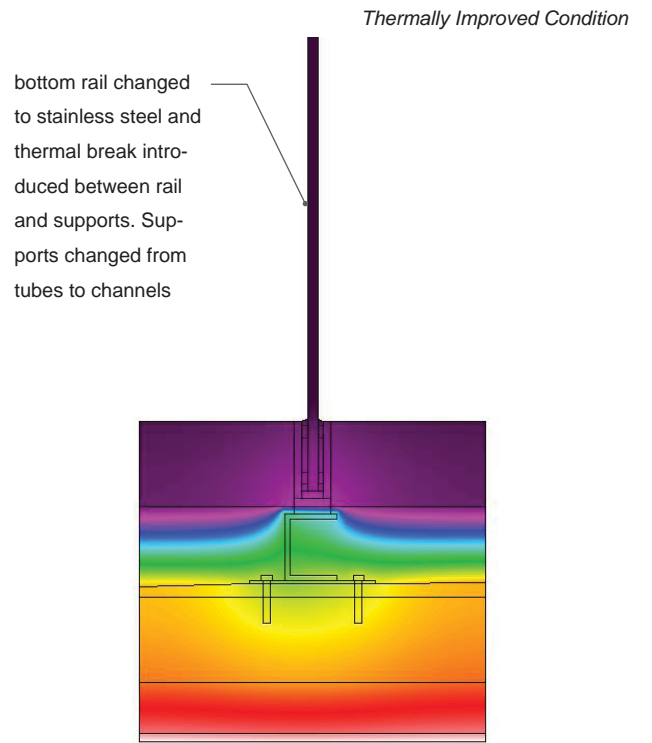

R-7.75
(+ 63.2%)

APPENDIX- 13a | LOUVERS: Mechanical Louver at Grade

Project Conditions

Location: Southern Massachusetts
 Date of Thermal Image: 02/09/2012
 Exterior Air Temperature: 32.3 °F
 Interior Air Temperature: 71.0 °F
 Radiant Temperature: N/A °F
 Assumed Emissivity: 0.9

Summary of Thermal Performance

Calculated Baseline R-Value: 11.49 -
As-Built Condition
 Simulated (THERM) R-Value: 5.68 - 58 %
Thermally Improved Condition
 Simulated (THERM) R-Value: 6.53 - 52 %

As-Built Condition

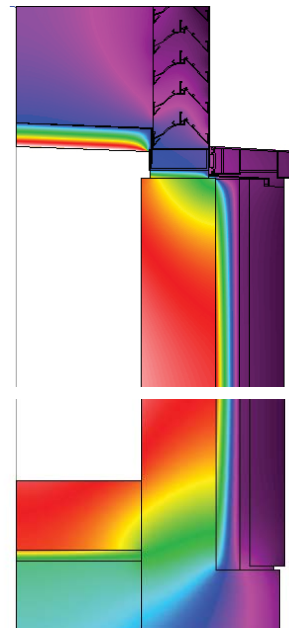
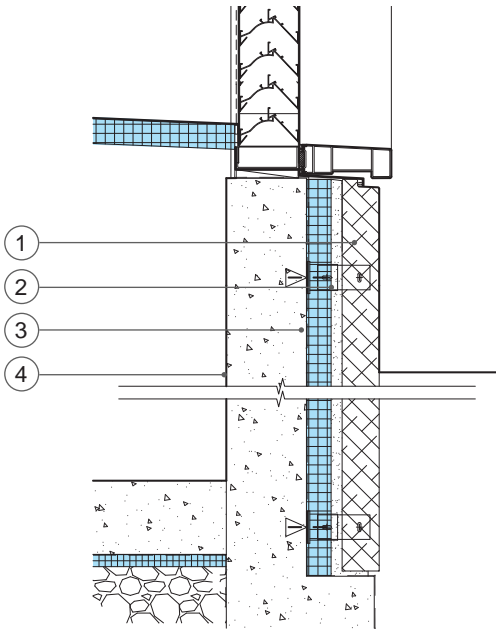

R-5.68

Calculated Baseline Clear Wall R-value									
	Material	Width in.	<i>k</i> Btu·in/h·ft ² ·°F	R-value h·ft ² ·°F/Btu		Material	Width in.	<i>k</i> Btu·in/h·ft ² ·°F	R-value h·ft ² ·°F/Btu
-	Exterior Air Film	-	-	0.17	④	Concrete	6.5	13.5	0.48
①	Granite	3.00	30.00	0.10	-	Interior Air Film	-	-	0.68
②	Grout	0.38	6.70	0.06					
③	Rigid Insulation	2.00	0.20	10.00					
								total	11.49

APPENDIX- 13a | LOUVERS: Mechanical Louver at Grade

Thermally Improved Condition

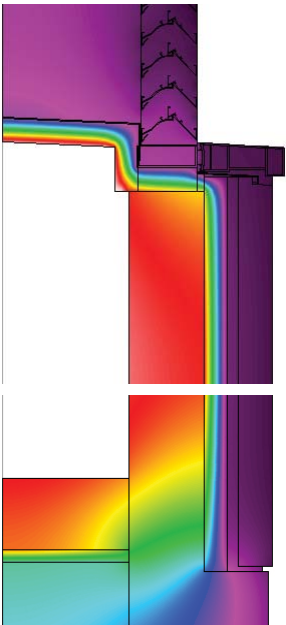
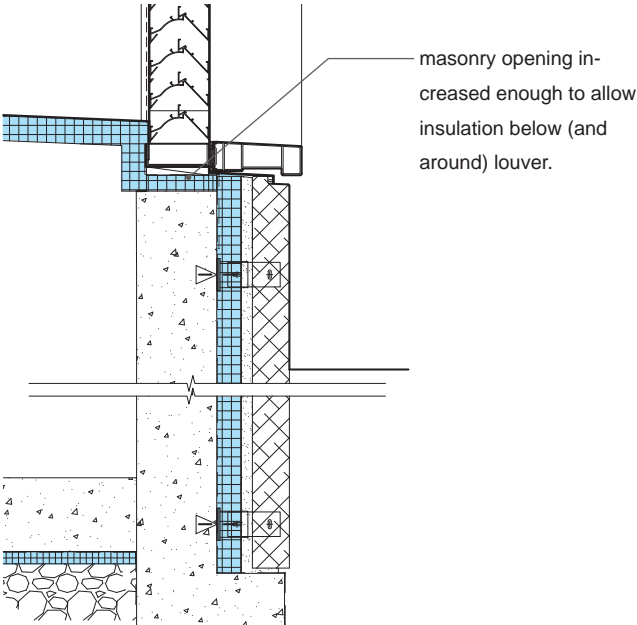

R-6.53
(+15%)

APPENDIX- 13b | LOUVERS: Mechanical Louver at Penthouse

Project Conditions

Location: Western Massachusetts
 Date of Thermal Image: 02/27/2012
 Exterior Air Temperature: 40.8 °F
 Interior Air Temperature: 72.2 °F
 Radiant Temperature: N/A °F
 Assumed Emissivity: 0.9

Summary of Thermal Performance

Calculated Baseline R-Value: 16.85 -
As-Built Condition
 Simulated (THERM) R-Value: 16.85
Thermally Improved Condition
 See continuous insulation at 13a

As-Built Condition

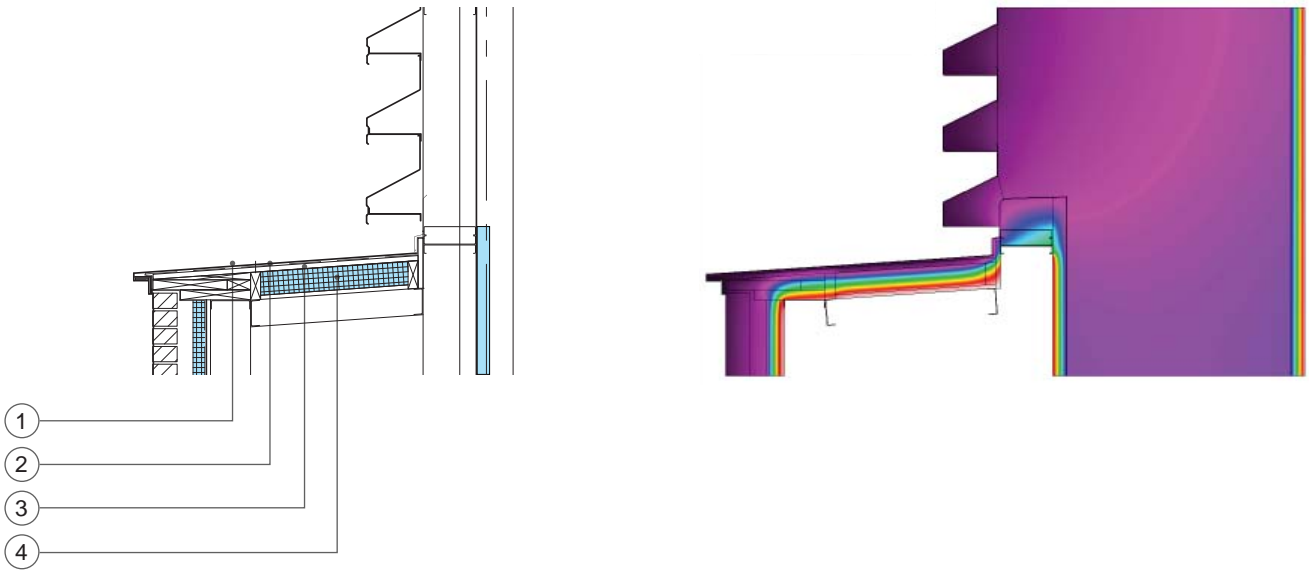

Calculated Baseline Clear Wall R-value									
	Material	Width in.	<i>k</i> Btu-in/h-ft ² ·°F	R-value h-ft ² ·°F/Btu		Material	Width in.	<i>k</i> Btu-in/h-ft ² ·°F	R-value h-ft ² ·°F/Btu
-	-	-	-	-	(2)	Aluminum Panel	0.13	136.94	0.00
-	-	-	-	-	(3)	Air Cavity	-	-	1.00
-	-	-	-	-	(4)	Rigid Insulation	3.00	0.20	15.00
(1)	Exterior Air Film	-	-	0.17	-	Interior Air Film	-	-	0.68
								total	16.85

APPENDIX- 13b | LOUVERS: Mechanical Louver at Penthouse



APPENDIX- 14a | EXISTING BUILDING BEAM EMBEDS: Thermal Break at Structural Connection

Project Conditions

Location: Eastern Massachusetts
 Date of Thermal Image: 01/23/2013
 Exterior Air Temperature: 12.2 °F
 Interior Air Temperature: 75.7 °F
 Radiant Temperature: 79.3 °F
 Assumed Emissivity: 0.9

Summary of Thermal Performance

Calculated Baseline R-Value: 29.17 -
As-Built Condition
 Thermal Image R-Value: 8.47 - 71 %
 Simulated (THERM) R-Value: 16.62 - 43 %
Thermally Improved Condition
 Simulated (THERM) R-Value: 22.66 - 22 %

As-Built Condition

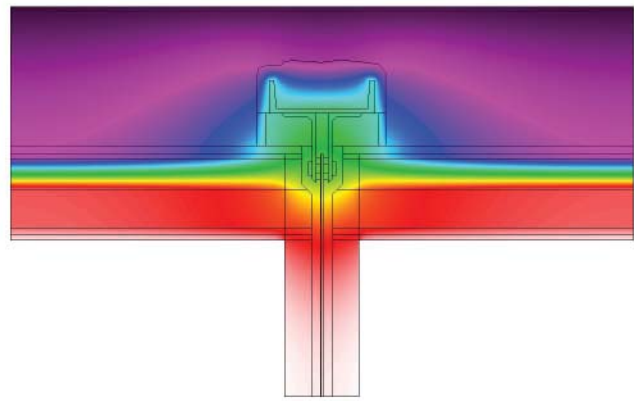
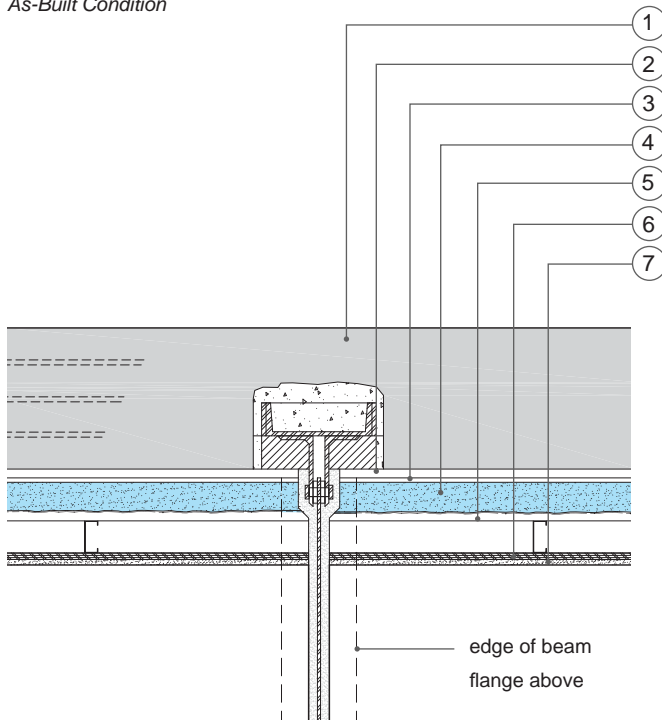

R-16.62

Calculated Baseline Clear Wall R-value									
	Material	Width in.	k Btu-in/h-ft2·°F	R-value h-ft2·°F/Btu		Material	Width in.	k Btu-in/h-ft2·°F	R-value h-ft2·°F/Btu
-	Exterior Air Film	-	-	0.17	(4)	Sprayfoam Insulation	3.5	0.1664	21.03
(1)	Brick	16	5.5	2.91	(5)	Air Cavity	4.5	-	1.36
(2)	Air Cavity	1	-	1.36	(6)	Plywood	0.75	1.1787	0.64
(3)	Cement Board	0.5	1.10	0.45	(7)	Gypsum Board	0.625	1.10	0.57
					-	Interior Air Film	-	-	0.68
								total	29.17

APPENDIX- 14a | EXISTING BUILDING BEAM EMBEDS: Thermal Break at Structural Connection



Digital Image



Infrared Image

Thermally Improved Condition

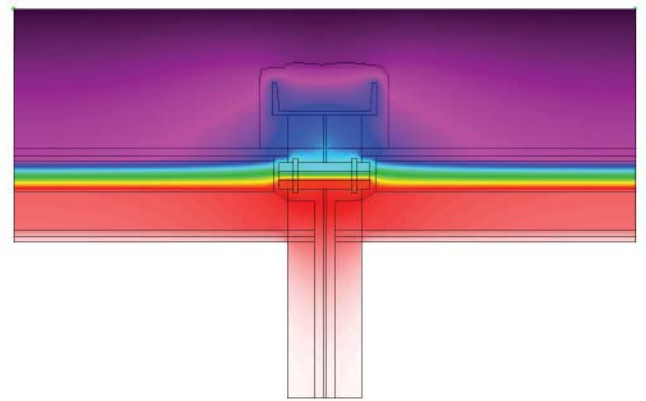
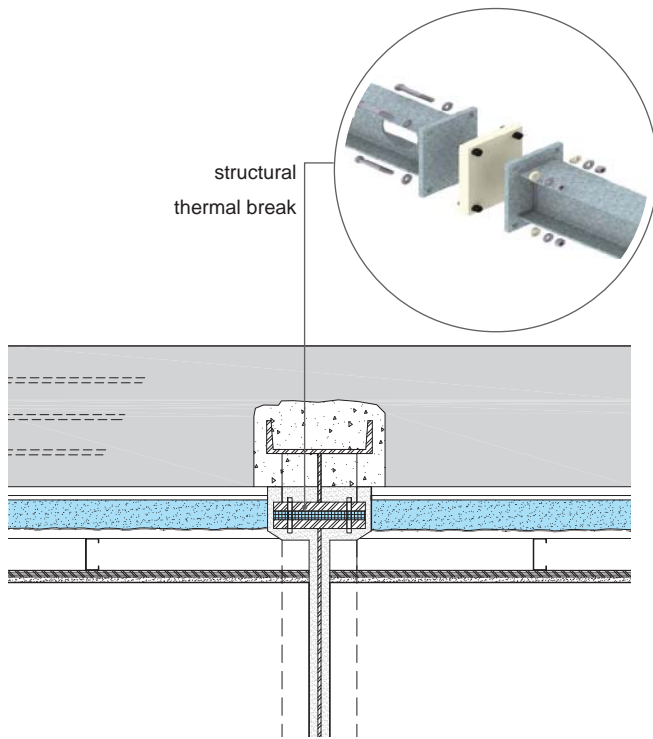

R-22.66
(+36%)

APPENDIX- 15a | NEW SLABS IN EXISTING BUILDINGS: Thermal Break at New Slab

Project Conditions

Location: Eastern Massachusetts
 Date of Thermal Image: 01/23/2013
 Exterior Air Temperature: 22.1 °F
 Interior Air Temperature: 53.7 °F
 Radiant Temperature: 55.8 °F
 Assumed Emissivity: 0.9

Summary of Thermal Performance

Calculated Baseline R-Value: 29.55 -
As-Built Condition
 Thermal Image R-Value: 15.33 - 48 %
 Simulated (THERM) R-Value: 16.14 - 45 %
Thermally Improved Condition
 Simulated (THERM) R-Value: 21.10 - 29 %

As-Built Condition

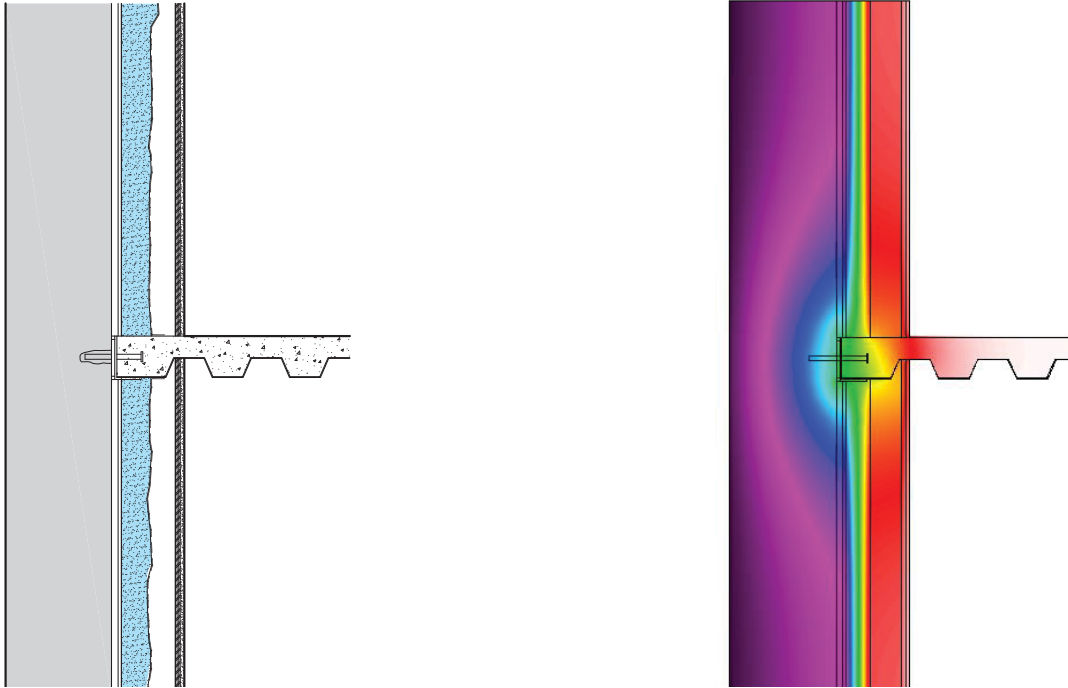

R-16.14

Calculated Baseline Clear Wall R-value									
	Material	Width in.	k Btu-in/h-ft2-°F	R-value h-ft2-°F/Btu		Material	Width in.	k Btu-in/h-ft2-°F	R-value h-ft2-°F/Btu
-	Exterior Air Film	-	-	0.17	(4)	Sprayfoam Insulation	3.5	0.1664	21.03
(1)	Brick	16	5.5	2.91	(5)	Air Cavity	4.5	-	1.36
(2)	Air Cavity	1	-	1.36	(6)	Plywood	0.75	0.735	1.02
(3)	Cement Board	0.5	1.10	0.45	(7)	Gypsum Board	0.625	1.10	0.57
					-	Interior Air Film	-	-	0.68
						total			29.55

APPENDIX- 15a | NEW SLABS IN EXISTING BUILDINGS: Thermal Break at New Slab



Digital Image

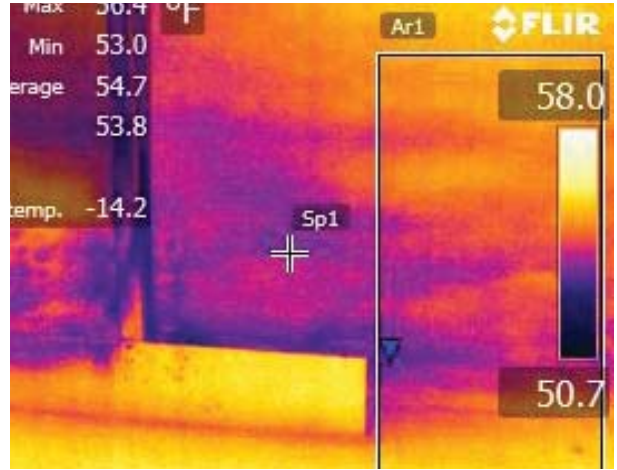

Infrared Image

Thermally Improved Condition

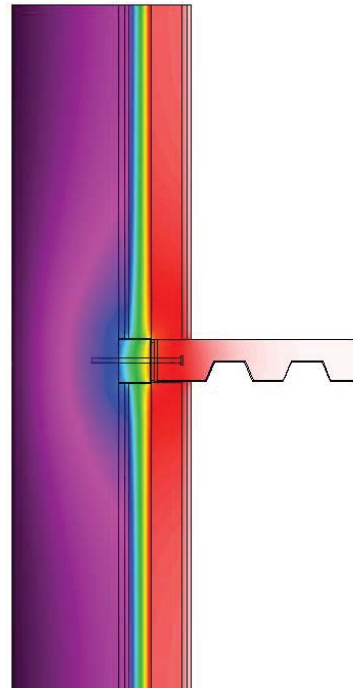
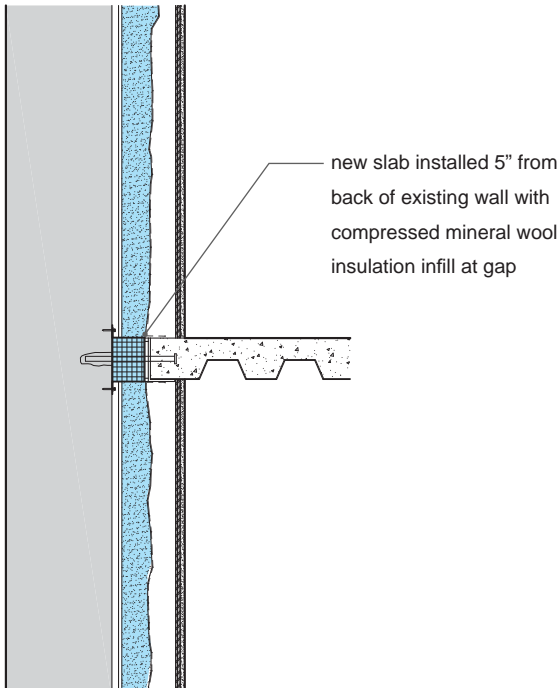

R-21.10
(+30.7%)

APPENDIX- 16a | SEISMIC & MOVEMENT JOINTS: Joint at Masonry Wall and Existing Building

Project Conditions

Location: Massachusetts
 Date of Thermal Image: 2/5/2013
 Exterior Air Temperature: 33.8 °F
 Interior Air Temperature: 63.8 °F
 Radiant Temperature: 51.3 °F
 Assumed Emissivity: 0.9

Summary of Thermal Performance

Calculated Baseline R-Value: 17.69 -
As-Built Condition
 Thermal Image R-Value: 6.77 - 62 %
 Simulated (THERM) R-Value: 7.88 - 55.5%
Thermally Improved Condition
 Simulated (THERM) R-Value: 13.72 - 22 %

As-Built Condition

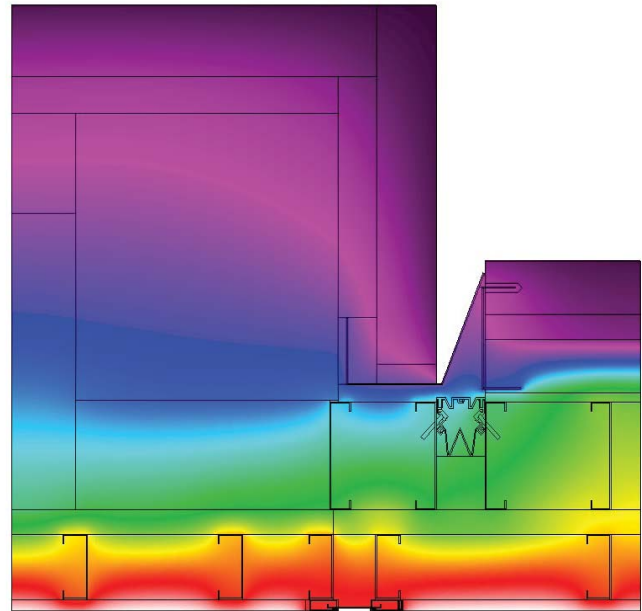
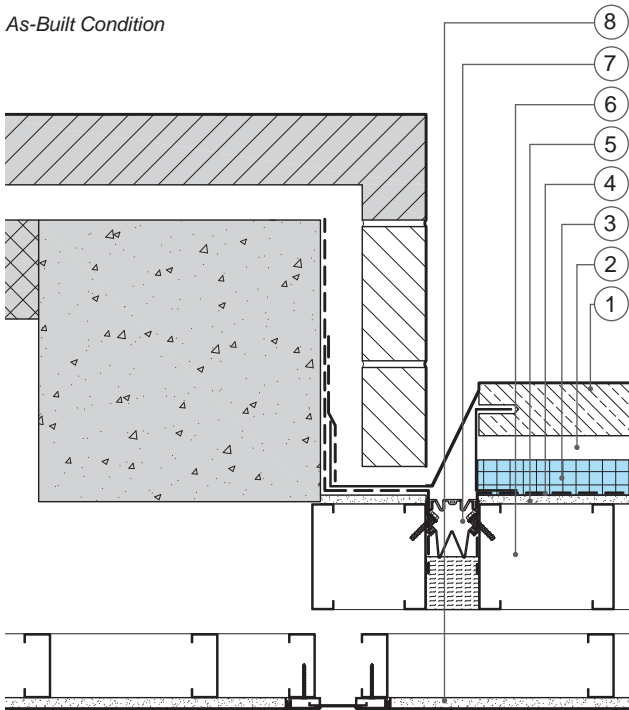

R-7.88

Calculated Baseline Clear Wall R-value									
	Material	Width in.	k Btu-in/h-ft2-°F	R-value h-ft2-°F/Btu		Material	Width in.	k Btu-in/h-ft2-°F	R-value h-ft2-°F/Btu
-	Exterior Air Film	-	-	0.17	(5)	Sheathing	0.50	1.10	0.45
(1)	Granite Veneer	3	30	0.10	(6)	Air Cavity	11	-	1.36
(2)	Air Cavity	-	-	1.36	(7)	Expansion Joint	-	-	-
(3)	Mineral Wool	3	0.23	13	(8)	Gypsum Board	0.625	1.10	0.57
(4)	Air and Vapor Barrier	-	-	-	-	Interior Air Film	-	-	0.68
								total	17.69

APPENDIX- 16a | SEISMIC & MOVEMENT JOINTS: Joint at Masonry Wall and Existing Building



Digital Image

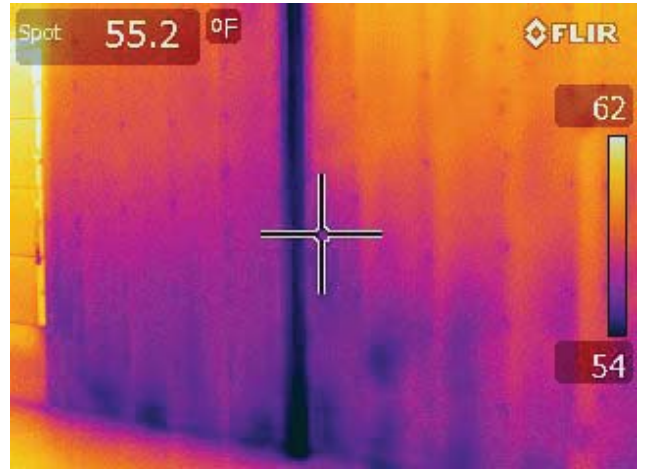

Infrared Image

Thermally Improved Condition

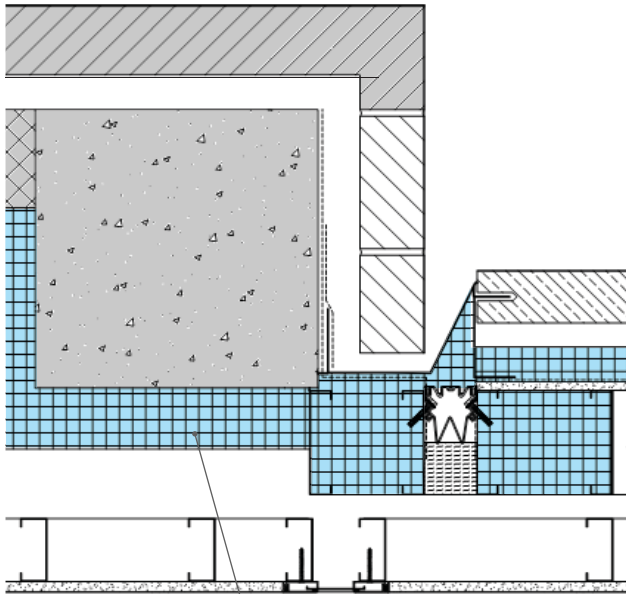

spray foam insulation
added to existing wall,
and at frame for joint

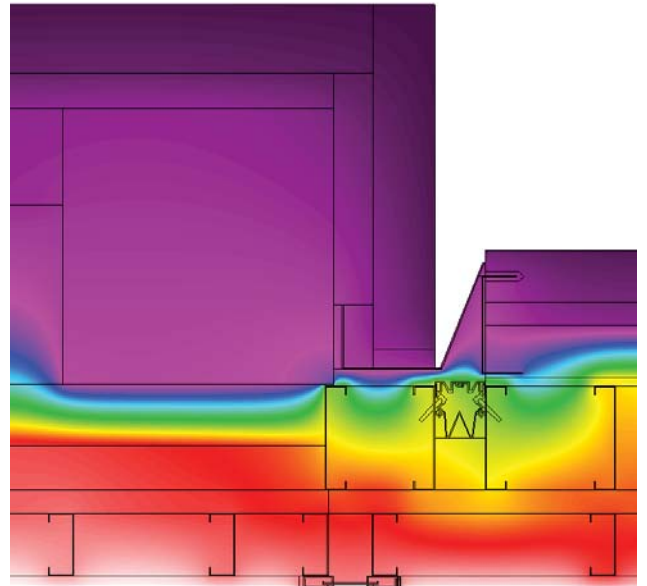

R-13.72
(+74%)

APPENDIX- 16b | SEISMIC & MOVEMENT JOINTS: Joint at Curtain Wall and Existing Building

Project Conditions

Location: Massachusetts
 Date of Thermal Image: 2/3/2013
 Exterior Air Temperature: 33.8 °F
 Interior Air Temperature: 72.7 °F
 Radiant Temperature: N/A °F
 Assumed Emissivity: 0.9

Summary of Thermal Performance

Calculated Baseline R-Value: 11.85 -
As-Built Condition
 Thermal Image R-Value: N/A N/A
 Simulated (THERM) R-Value: 2.30 - 81%
Thermally Improved Condition
 Simulated (THERM) R-Value: N/A N/A

As-Built Condition

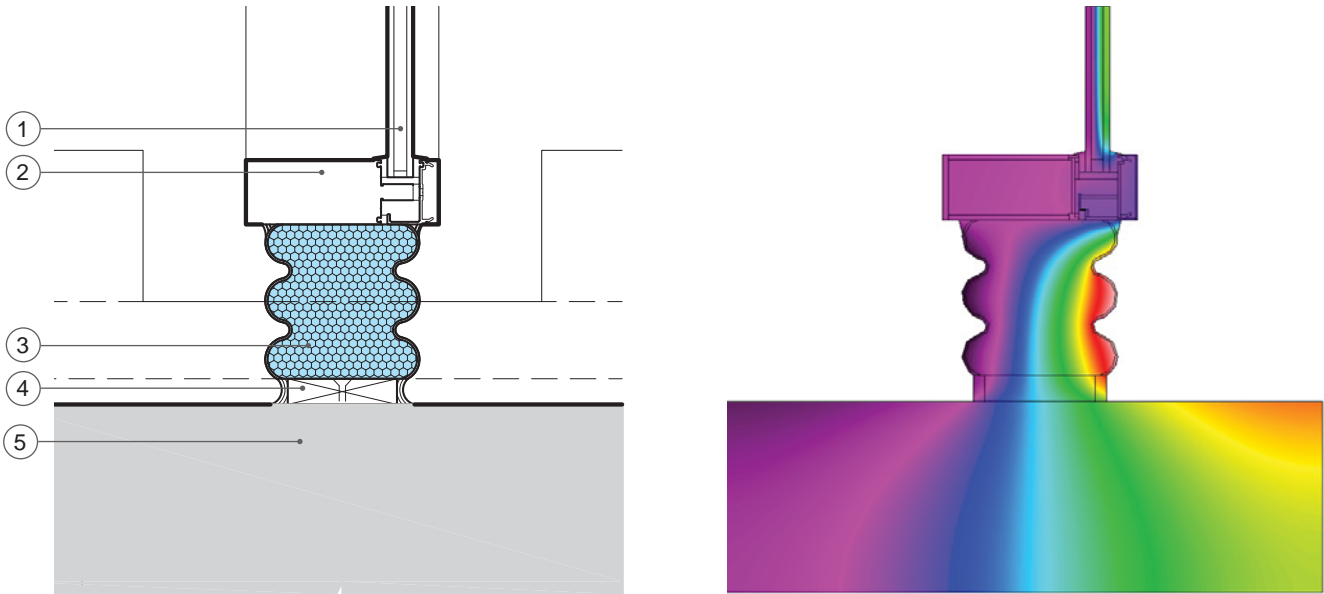

Calculated Baseline Clear Wall R-value (at Expsion Joint)									
	Material	Width in.	k Btu-in/h-ft2-°F	R-value h-ft2-°F/Btu		Material	Width in.	k Btu-in/h-ft2-°F	R-value h-ft2-°F/Btu
					(3)	Expansion Joint	6	0.55	11
-	Exterior Air Film	-	-	0.17	(4)	Wood Blocking	-	-	-
(1)	Insulated Glazing	-	-	-	(5)	Existing Masonry	-	-	-
(2)	Curtain Wall Mullion	-	-	-	-	Interior Air Film	-	-	0.68
								total	11.85

APPENDIX- 16b | SEISMIC & MOVEMENT JOINTS: Joint at Curtain Wall and Existing Building



Digital Image

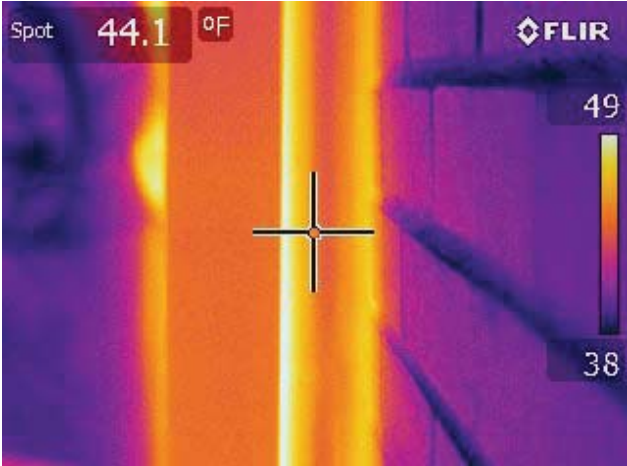

Infrared Image